

X9460

Low Noise, Low Cost, High End Features, Dual Audio Log Potentiometer Dual Audio Control Digitally Controlled Potentiometer (XDCP™)

FN8203
Rev 2.00
October 17, 2005

The X9460 integrates two digitally controlled potentiometer (XDCP) on a monolithic CMOS integrated circuit. The two XDCPs can be used as stereo gain controls in audio applications. Read/Write operations can directly access each channel independently or both channels simultaneously. Increment/Decrement can adjust each channel independently or both channels simultaneously.

The X9460 contains a zero amplitude wiper switching circuit that delays wiper changes until the next zero crossing of the audio signal.

The digitally controlled potentiometer is implemented using 31 polysilicon resistors in a log array. Between each of the resistors are tap points connected to the wiper terminal through switches. The XDCPs are designed to minimize wiper noise to avoid pops and clicks during audio volume transitions. The position of the wiper on the array is controlled by the user through the 2-wire serial bus interface.

Power-up reset the wiper to the mute position.

Pinout

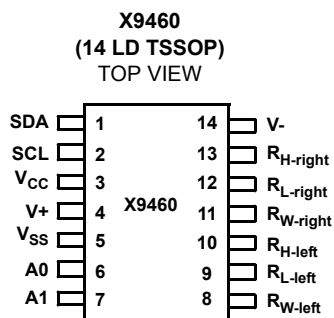

Features

- Dual Audio Control – Two 32 Taps Log Pots
- Zero Amplitude Wiper Switching
- 2-Wire Serial Interface
4 Slave Byte Addresses for Writes[A1,A0]
- Total Resistance: 33kΩ Each XDCP (Typical)
- Dual Voltage Operation
V+/V- = ±2.7 to ±5.5V
- Temp Range = -40°C to +85°C
- Package Options
14 L d TSSOP
- Zero Amplitude Wiper Switching
- Pb-Free Plus Anneal Available (RoHS Compliant)

Audio Performance

- 0 to -62dB Volume Control
- -92dB Mute
- Power-Up to Mute Position
- SNR -96dB
- THD+N: -95dB @1kHz
- Crosstalk Rejection: -102dB @ 1kHz
- Channel-to-Channel Variation: ± 0.1dB
- 3dB-Cutoff: 100kHz

Applications

- Set Top Boxes
- Stereo Amplifiers
- DVD Players
- Portable Audio Products

Ordering Information

PART NUMBER	PART MARKING	V _{CC} LIMITS (V)	TEMP RANGE (°C)	PACKAGE
X9460KV14I*	X9460KV I	5V ± 10%	-40 to +85	14 Ld TSSOP
X9460KV14IZ* (Note)	X9460KV Z I		-40 to +85	14 Ld TSSOP (Pb-free)
X9460KV14I-2.7*	X9460KV G	2.7 to 5.5	-40 to +85	14 Ld TSSOP
X9460KV14IZ-2.7* (Note)	X9460KV Z G		-40 to +85	14 Ld TSSOP (Pb-free)

*Add "T1" suffix for tape and reel.

NOTE: Intersil Pb-free plus anneal products employ special Pb-free material sets; molding compounds/die attach materials and 100% matte tin plate termination finish, which are RoHS compliant and compatible with both SnPb and Pb-free soldering operations. Intersil Pb-free products are MSL classified at Pb-free peak reflow temperatures that meet or exceed the Pb-free requirements of IPC/JEDEC J STD-020.

Simplified Functional Diagram

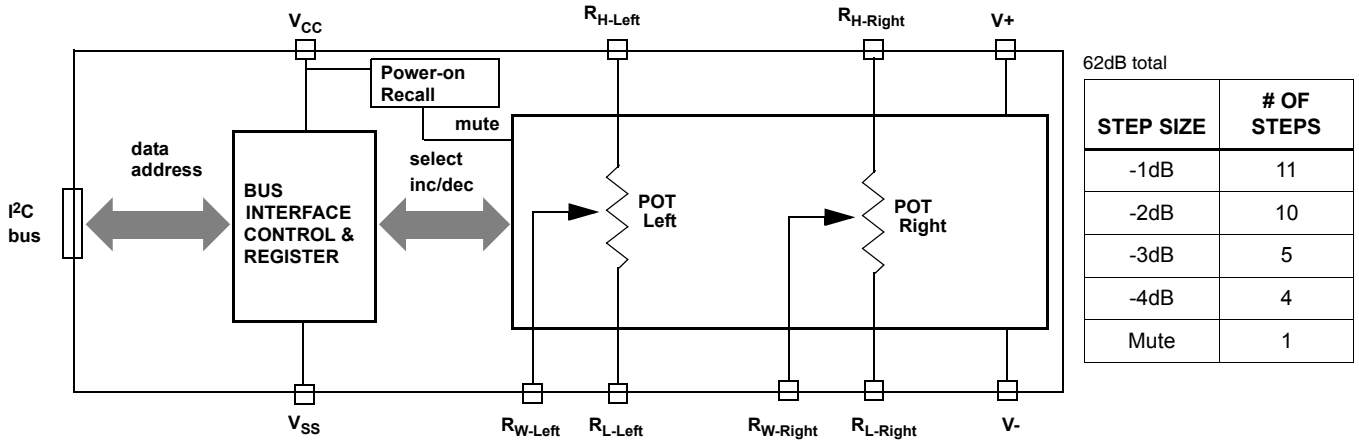

Detailed Functional Diagram

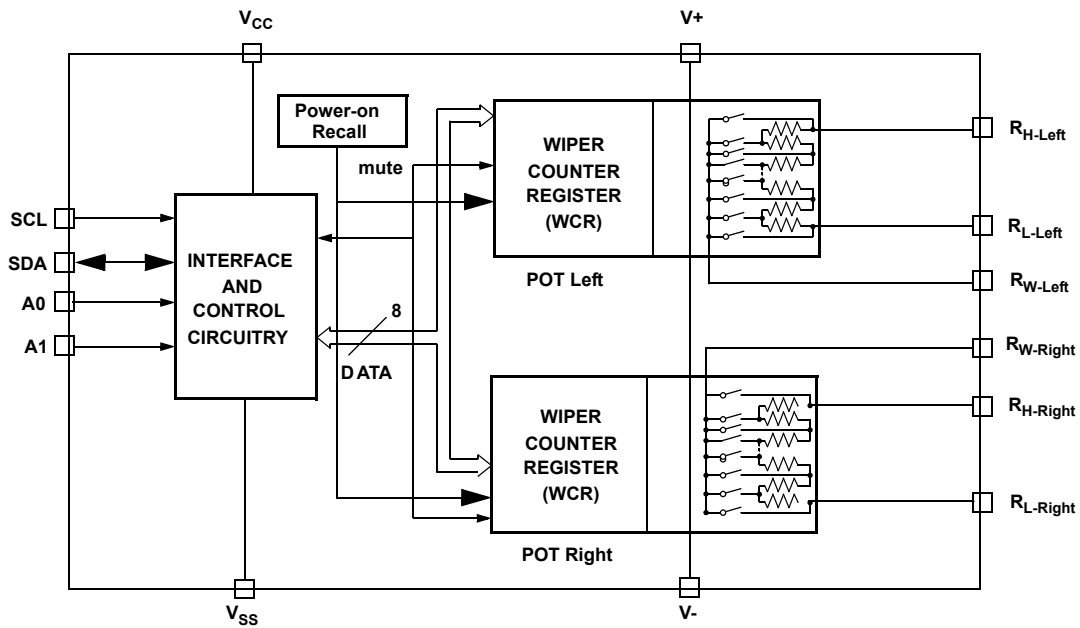

Typical Application

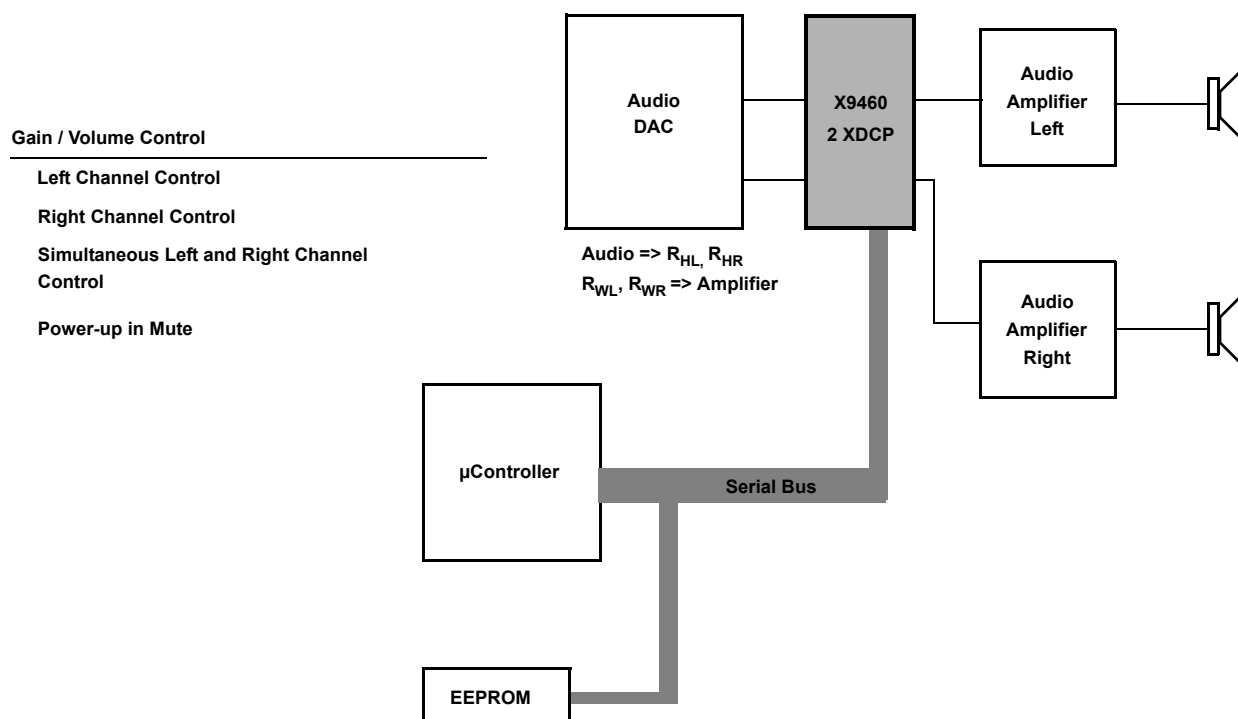

Pin Assignments

PIN (TSSOP)	SYMBOL	FUNCTION
1	SDA	Serial Data
2	SCL	Serial Clock
3	V _{CC}	System Supply Voltage
4	V+	Positive Analog Supply
5	V _{SS}	System Ground
6	A0	Device Address
7	A1	Device Address
8	R _{W-left}	Wiper terminal of the Left Potentiometer
9	R _{L-left}	Negative terminal of the Left Potentiometer
10	R _{H-left}	Positive terminal of the Left Potentiometer
11	R _{W-right}	Wiper terminal of the Right Potentiometer
12	R _{L-right}	Negative terminal of the Right Potentiometer
13	R _{H-right}	Positive terminal of the Right Potentiometer
14	V-	Negative Analog Supply

Detailed Pin Description

Host Interface Pins

SERIAL CLOCK (SCL)

The SCL input clocks data into and out of the X9460.

SERIAL DATA (SDA)

SDA is a bidirectional pin used to transfer data into and out of the device. It is an open drain output and may be wire-ORed with any number of open drain or open collector outputs. An open drain output requires the use of a pull-up resistor. For selecting typical values, refer to the guidelines for calculating typical values on the bus pull-up resistors graph.

DEVICE ADDRESS (A₁ - A₀)

The Address inputs are used to set the least significant 2 bits of the 8-bit Slave Byte Address. A match in the slave address serial data stream must be made with the Address input in order to initiate communication with the X9460. Up to 4 X9460s may be connected to a single I²C serial bus and written to (NOTE: you cannot read from more than one device on the same 2-wire bus). If left floating, these pins are internally pulled to ground.

Slave Byte (bits, MSB-LSB) = 0101 0 A₁ A₀ R/W

Potentiometer Pins

R_{H-LEFT}, R_{L-LEFT}, R_{H-RIGHT}, R_{L-RIGHT}

The R_H and R_L inputs are equivalent to the terminal connections on either end of a mechanical potentiometer.

R_{W-LEFT}, R_{W-RIGHT}

The wiper outputs are equivalent to the wiper output of a mechanical potentiometer.

Supply Pins

ANALOG SUPPLY V₋ AND V₊

The positive power supply for the DCP analog control section is connected to V₊. The negative power supply for the DCP analog control section is connected to V₋.

DIGITAL SUPPLIES V_{CC}, V_{SS}

The power supplies for the digital control sections.

Power-up and Down Recommendations

There are no restrictions on the power-up condition of V_{CC}, V₊ and V₋ and the voltages applied to the potentiometer pins provided that the V_{CC} and V₊ are more positive or equal to the voltage at R_H, R_L, and R_W, ie. V_{CC}, V₊ > R_H, R_L, R_W. At all times, the voltages on the potentiometer pins must be less than V₊ and more than V₋.

The following V_{CC} ramp rate spec is always in effect.

0.2 V/ms < V_{CC} ramp < 50 V/ms

The V_{SS} pin is always connected to the system common or ground. V_H, V_L, V_W are the voltages on the R_H, R_L, and R_W potentiometer pins.

X9460 Principles of Operation

The X9460 is a highly integrated microcircuit incorporating two resistor arrays with their associated registers, counters and the serial interface logic providing direct communication between the host and the DCP potentiometers. This section provides detailed description as following:

- Resistor Array Description
- Serial Interface Description
- Command Set and Register Information Description

Resistor Array Description

The X9460 is comprised of two resistor arrays. Each array contains 31 discrete resistive segments that are connected in series. The physical ends of each array are equivalent to the fixed terminals of a mechanical potentiometer (R_H and R_L inputs). Tables 1 and 2 provide a description of the step size and tap positions.

At both ends of each array and between each resistor segment is a CMOS switch connected to the wiper (R_W) output. Within each individual array only one switch may be turned on at a time. These switches are controlled by the Wiper Counter Register (WCR). The five bits of the WCR are decoded to select, and enable, one of thirty-two switches.

TABLE 1. TOTAL -62dB RANGE PLUS MUTE POSITION

STEP SIZE	# OF STEPS
-1dB	11 steps
- 2dB	10 steps
- 3dB	5 steps
- 4dB	4 steps
Mute	1 step

TABLE 2. WIPER TAP POSITION vs dB

TAP POSITION, n	dB	MIN/MAX dB
for n = 20 to 31	n - 31	-11/0
for n = 10 to 19	2n-51	-31/-13
for n = 5 to 9	3n-61	-46/-34
for n = 1 to 4	4n-66	-62/-50
n = 0	-92	-92

Serial Interface Description

Serial Interface

The X9460 supports a bidirectional bus oriented protocol. The protocol defines any device that sends data onto the bus as a transmitter and the receiving device as the receiver. The device controlling the transfer is a master and the device being controlled is the slave. The master will always initiate data transfers and provide the clock for both transmit and receive operations. The X9460 is a slave device in all applications.

Clock and Data Conventions

Data states on the SDA line can change only during SCL LOW periods. SDA state changes during SCL HIGH are reserved for indicating start and stop conditions.

Start Condition

All commands to the X9460 are preceded by the start condition, which is a HIGH to LOW transition of SDA while SCL is HIGH. The X9460 continuously monitors the SDA and SCL lines for the start condition and will not respond to any command until this condition is met.

Stop Condition

All communications must be terminated by a stop condition, which is a LOW to HIGH transition of SDA while SCL is HIGH.

Acknowledge

Acknowledge is a software convention used to provide a positive handshake between the master and slave devices on the bus to indicate the successful receipt of data. The transmitting device, either the master or the slave, will release the SDA bus after transmitting eight bits. The master generates a ninth clock cycle and during this period the receiver pulls the SDA line LOW to acknowledge that it successfully received the eight bits of data.

The X9460 will respond with an acknowledge: 1) after recognition of a start condition and after an identification and slave address byte, and 2) again after each successful receipt of the instruction or databyte. See Figure 1.

Invalid Commands

For any invalid commands or unrecognizable addresses, the X9460 will NOT acknowledge and return the X9460 to the idle state.

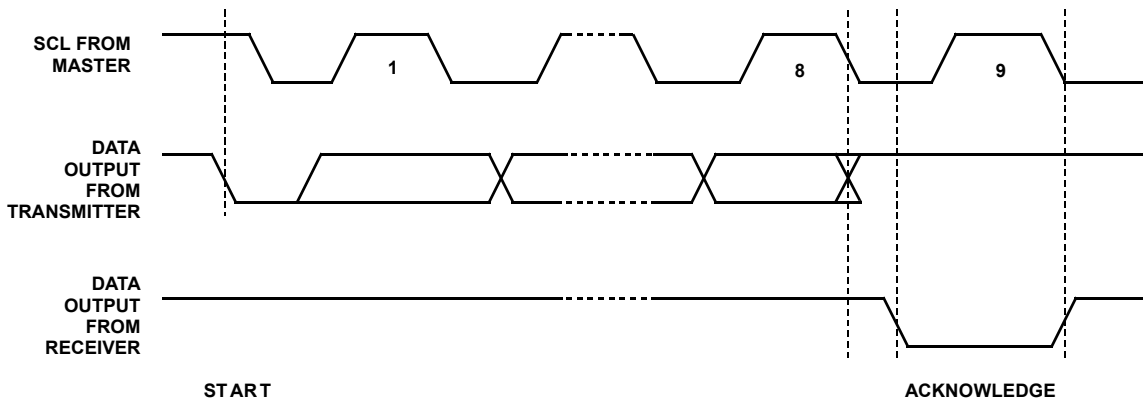

FIGURE 1. ACKNOWLEDGE RESPONSE FROM RECEIVER

Command Set and Register Description

Device Addressing

Following a start condition the master must output the Slave Byte Address of the slave it is accessing. The most significant four bits of the slave address are the device type identifier (refer to Figure 2). For the X9460 this is fixed as 0101.

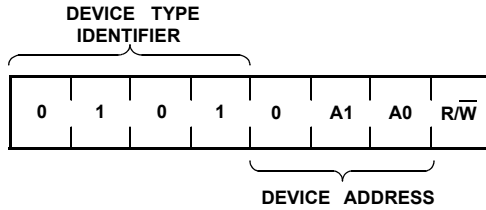

FIGURE 2. SLAVE BYTE ADDRESS

The next three bits of the Slave Byte Address are the device address. The device address is defined by the $A_1 - A_0$ inputs. The X9460 compares the serial data stream with the Slave Byte Address; a successful compare is required for the X9460 to respond with an acknowledge. The $A_1 - A_0$ inputs can be actively driven by CMOS input signals or tied to V_{CC} or V_{SS} . The R/\bar{W} bit sets the device for read or write operations. Note that the X9460 supports reads and writes to a single device on the 2-wire bus. If more than one X9460 is used on the same 2-wire bus, those devices must have unique device addresses and only writes are supported. You may not read from multiple devices or contention will result and the data is not valid.

Command Set

After a Slave Byte Address match, the next byte sent contains the Command and register pointer information. The four most significant bits are the Command. The next bit is a “X” (don’t care) set to zero.

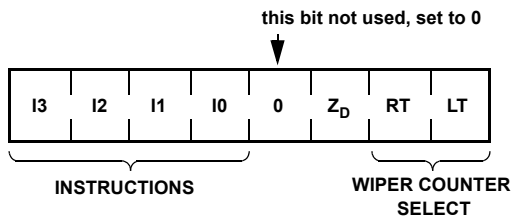

FIGURE 3. COMMAND BYTE FORMAT

The Z_D bit enables and disables the Zero Amplitude Wiper Switching circuit. When $Z_D=1$, the wiper switches will turn on when close-to-zero amplitude is detected across the potentiometer pins. When $Z_D=0$, this circuit is disabled. The last two bits, LT (left POT enable) and RT (right POT enable), select which of the two potentiometers is affected by the instruction.

Several instructions require a three-byte sequence to complete. These instructions transfer data between the host

and the X9460. These instructions are: Read Wiper Counter Register, Write Wiper Counter Register. The sequence of operations is shown in Figure 4 and 5. The four-byte command is used for write command for both right and left pots (Figure 6).

Special Commands

Increment/Decrement Instruction. The Increment/Decrement command is different from the other commands. Once the command is issued and the X9460 has responded with an acknowledge, the master can clock the selected wiper up and/or down. For each SCL clock pulse (t_{HIGH}) while SDA is HIGH, the selected wiper will move one resistor segment towards the R_H terminal. Similarly, for each SCL clock pulse while SDA is LOW, the selected wiper will move one resistor segment towards the R_L terminal. A detailed illustration of the sequence and timing for this operation are shown in Figures 7 and 8 respectively.

Wiper Counter Register

The X9460 contains two Wiper Counter Registers. The Wiper Counter Register output is decoded to select one of thirty-two switches along its resistor array. The Write Wiper Counter Register command directly sets the WCR to a value. The Increment/Decrement instruction steps the register value up or down one to multiple times.

The WCR is a volatile register (Table 3) and is reset to the mute position (tap 0, “zero”) at power-up.

TABLE 3. WIPER COUNTER REGISTERS, 5-bit - VOLATILE:

WCR4	WCR3	WCR2	WCR1	WCR0
(MSB)			(LSB)	

The X9460 contains one 5-bit Wiper Counter Register for each DCP. (Two 5-bit registers in total.)

TABLE 4. COMMAND SET

INSTRUCTION	INSTRUCTION SET								OPERATION
	I ₃	I ₂	I ₁	I ₀	X	Z _D	RT	LT	
Read Wiper									LSB of Slave Byte=1, no command required Slave will return Left then Right Data(not to be used with more than one device on the 2-wire bus)
Write Left Wiper Counter	1	0	1	0	0	1/0	0	1	Write new value to the Wiper Counter Register
Write Right Wiper Counter	1	0	1	0	0	1/0	1	0	Write new value to the Wiper Counter Register
Write Both Wiper Counters	1	0	1	0	0	1/0	1	1	Write new value to the Wiper Counter Register
Inc/Dec Left Wiper Counter	0	0	1	0	0	1/0	0	1	Enable Increment/decrement of the Control Latch
Inc/Dec Right Wiper Counter	0	0	1	0	0	1/0	1	0	Enable Increment/decrement of the Control Latch
Inc/Dec Both Wiper Counters	0	0	1	0	0	1/0	1	1	Enable Increment/decrement of the Control Latch

Notes: "1/0" = data is one or zero

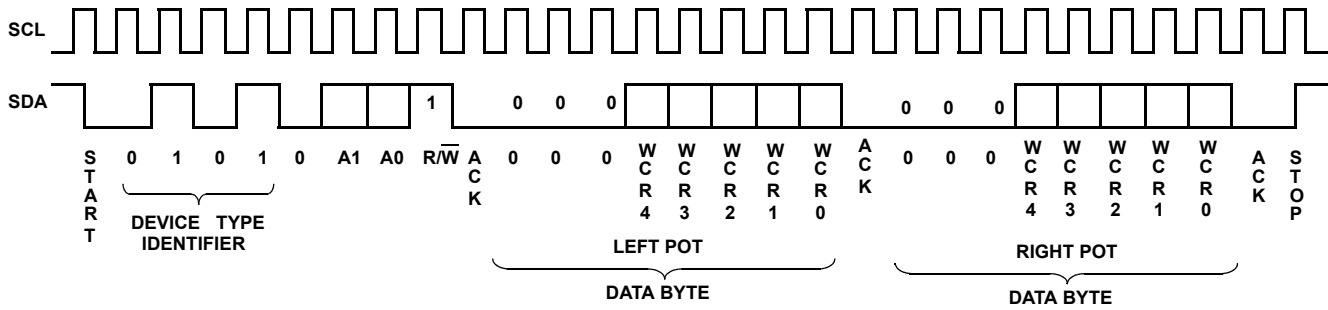

FIGURE 4. THREE-BYTE COMMAND SEQUENCE (READ, SINGLE DEVICE ON THE 2-WIRE BUS ONLY)

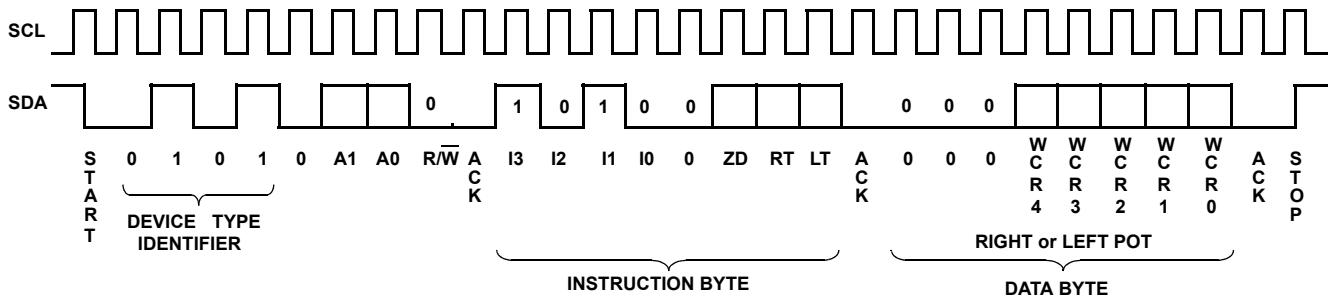

FIGURE 5. THREE-BYTE COMMAND SEQUENCE (WRITE)

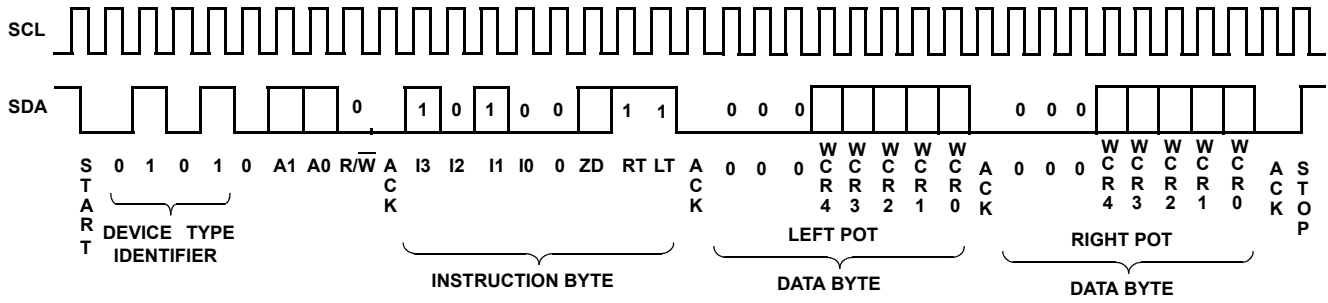

FIGURE 6. FOUR-BYTE COMMAND SEQUENCE (WRITE)

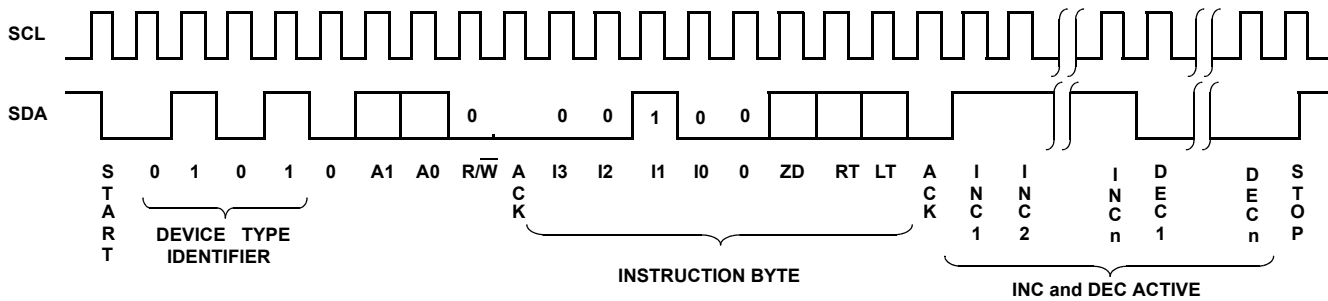
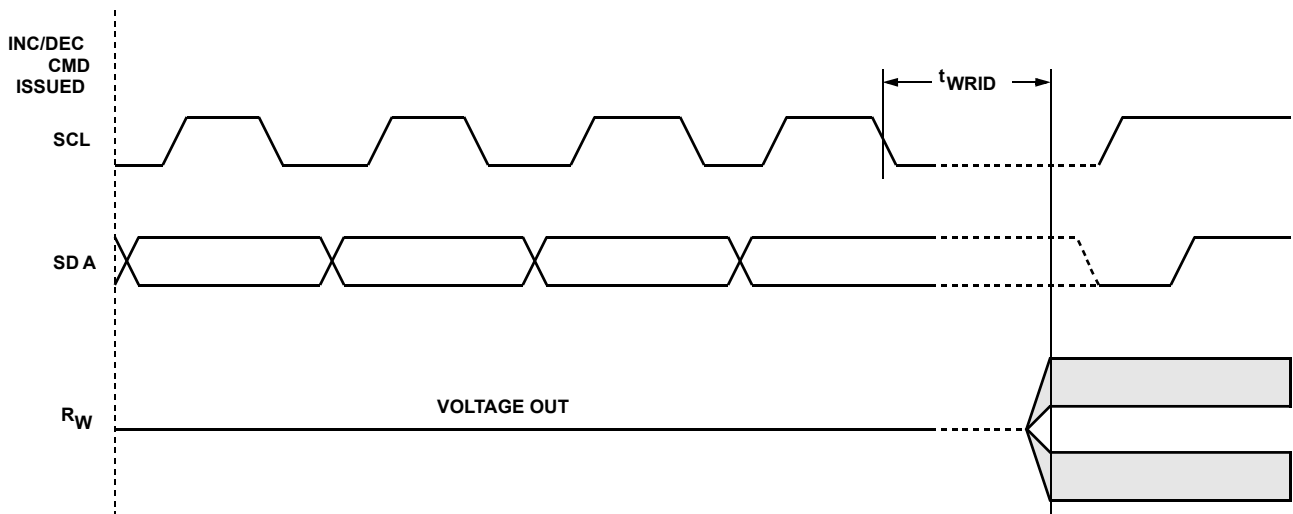

FIGURE 7. INCREMENT/DECREMENT COMMAND SEQUENCE (WRITE)



Wiper can move within 10 μ s after the falling edge of SCL

FIGURE 8. INCREMENT/DECREMENT TIMING LIMITS

Instruction Formats

Read Wiper Counter Register (Single device on 2-wire bus only)

S T A R T	device type identifier				device addresses			S A C K	Left wiper position (sent by slave on SDA)						M A C K	Right wiper position (sent by slave on SDA)						M A C K	S T O P			
	0	1	0	1	0	A1	A0		R/W=1	0	0	0	L4	L3		L2	L1	L0	0	0	0			R4	R3	R2
	0	1	0	1	0	A1	A0	R/W=1	0	0	0	L4	L3	L2	L1	L0	0	0	0	R4	R3	R2	R1	R0		

Write Wiper Counter Register

S T A R T	device type identifier				device addresses			S A C K	instruction opcode			wiper addresses			S A C K	Left or Right wiper position (sent by master on SDA)						S A C K	S T O P			
	0	1	0	1	0	A1	A0		R/W=0	1	0	1	0	0		ZD	RT	LT	0	0	0			D4	D3	D2
	0	1	0	1	0	A1	A0	R/W=0	1	0	1	0	0	ZD	RT	LT	0	0	0	D4	D3	D2	D1	D0		

Write Both Wiper Counter Registers

S T A R T	device type identifier				device addresses			S A C K	instruction opcode			wiper addresses			S A C K	Left wiper position (sent by master on SDA)						S A C K	Right wiper position (sent by master on SDA)						S A C K	S T O P				
	0	1	0	1	0	A1	A0		R/W=0	1	0	1	0	0		ZD	1	1	0	0	0		L4	L3	L2	L1	L0	0			0	0	R4	R3
	0	1	0	1	0	A1	A0	R/W=0	1	0	1	0	0	ZD	1	1	0	0	0	L4	L3	L2	L1	L0	0	0	0	R4	R3	R2	R1	R0		

Increment/Decrement Wiper Counter Register

S T A R T	device type identifier				device addresses			S A C K	instruction opcode			wiper addresses			S A C K	increment/decrement (sent by master on SDA)						S T O P				
	0	1	0	1	0	A1	A0		R/W=0	0	0	1	0	0		ZD	RT	LT	I/D	I/D	I/D
	0	1	0	1	0	A1	A0	R/W=0	0	0	1	0	0	ZD	RT	LT	I/D	I/D	I/D	I/D		

Definitions:

1. "MACK"/"SACK": stands for the acknowledge sent by the master/slave.
2. "A1 ~ A0": stands for the device addresses sent by the master.
3. "I": stands for the increment operation, SDA held high during active SCL phase (high).
4. "D": stands for the decrement operation, SDA held low during active SCL phase (high).

Absolute Maximum Ratings

Temperature under Bias	-65°C to +135°C
Storage Temperature	-65°C to +150°C
Voltage on SDA, SCL or any Address Input with Respect to V_{SS}	-1V to +6V
Voltage on V+ (referenced to V_{SS})	+6V
Voltage on V- (referenced to V_{SS})	-6V
(V+) - (V-)	12V
Any R_H	V+
Any R_L	V-
Lead Temperature (Soldering, 10s)	300°C
I_W max (10s)	±3mA

Recommended Operating Conditions

Temperature Range (Industrial)	-40°C to 85°C
X9460V14-2.7	
Supply Voltage (V_{CC})	2.7V to 5.5V
V- Limits	-5.5V to -2.7V
V+ Limits	+2.7V to +5.5V

CAUTION: Stresses above those listed under "Absolute Maximum Ratings" may cause permanent damage to the device. This is a stress rating only; functional operation of the device (at these or any other conditions above those listed in the operational sections of this specification) is not implied. Exposure to absolute maximum rating conditions for extended periods may affect device reliability.

Analog Specifications Over the recommended operating conditions unless otherwise specified (Note 1)

SYMBOL	PARAMETER	TEST CONDITIONS	MIN	TYP	MAX	UNIT
DYNAMIC PERFORMANCE (Notes 2, 3)						
	Control Range		-62		0	dB
	Mute Mode	@1V rms		-92		dB
SNR	Signal Noise Ratios (Unweighted)	@1V rms @ 1kHz, Tap = -6dB		-96		dB
THD + N	Total Harmonic Distortion + Noise	@1V rms @ 1kHz, Tap = -6dB		-95		dB
XTalk	DCP Isolation	@1kHz, tap = -6dB		-102		dB
	Digital Feedthrough (Peak Component)	tap = -6dB		-105		dB
	-3db Cutoff Frequency			100		kHz
DC ACCURACY						
	Step Size	Steps of -1, -2, -3, -4 dB	-1		-4	dB
	Step Size Error	For -1dB steps	-0.2		+0.2	dB
	Step Size Error	For -2dB steps	-0.4		+0.4	dB
	Step Size Error	For -3dB steps	-0.6		+0.6	dB
	Step Size Error	For -4dB steps	-0.8		+0.8	dB
	DCP to DCP Matching		-0.1		0.1	dB

NOTES:

- $V_{CC} = |V-|$
 V_{CC} Ramp up timing $0.2V/ms < V_{CC}$ Ramp Rate $< 50V/ms$
- This parameter is guaranteed by design and characterization
- $T_A = 25^\circ C$, $V_{CC} = 5.0V$; 2 Hz to 20kHz Measurement Bandwidth with 80kHz filter, input signal 1Vrms, 1kHz Sine Wave.

Analog Specifications Over the recommended operating conditions unless otherwise specified (Note 1)

ANALOG INPUTS						
SYMBOL	PARAMETER	TEST CONDITIONS	MIN	TYP	MAX	UNIT
V_{TERM}	Voltage on R_L , R_W , and R_H pins		V-		V+	V
R_{TOTAL}	End to End Resistance	Typical 33k Ω	-20		+20	%
Cin (Note 4)	Input Capacitance R_L , R_H , R_W	$T_A = 25^\circ C$		25		pF
I_W (Note 2)	Wiper Current		-3		+3	mA
R_W	Wiper Resistance	Wiper Current = ±3mA		100	200	Ω
V-	Voltage on V- pin		-5.5		-2.7	V
V+	Voltage on V+ pin		+2.7		+5.5	V

Analog Specifications Over the recommended operating conditions unless otherwise specified (Note 1) **(Continued)**

ANALOG INPUTS						
SYMBOL	PARAMETER	TEST CONDITIONS	MIN	TYP	MAX	UNIT
	Noise	20Hz to 20kHz, Grounded Input @ -6dB tap		2		μVrms
TC_R (Note 2)	Temperature Coefficient of resistance			-300		PPM/ $^{\circ}\text{C}$

DC Electrical Specifications Over the recommended operating conditions unless otherwise specified. (Note 1)

SYMBOL	PARAMETER	TEST CONDITIONS	LIMITS			
			MIN	TYP	MAX	UNITS
I_{CC1}	V_{CC} Supply Current (Move Wiper, Write, Read)	$f_{SCL} = 400\text{kHz}$, SDA = Open, Other Inputs = V_{SS}		200	300	μA
I_{SB}	V_{CC} Current (Standby)	SCL = SDA = V_{CC} , Addr. = V_{SS}		3		μA
I_{LI}	Input Leakage Current	$V_{IN} = V_{SS}$ to V_{CC}		1	10	μA
I_{AI}	Analog Input Leakage	$V_{IN} = V^-$ to V^+ with all other analog inputs floating		0.1		μA
I_{LO}	Output Leakage Current	$V_{OUT} = V_{SS}$ to V_{CC}			10	μA
V_{IH}	Input HIGH Voltage		$V_{CC} \times 0.7$		$V_{CC} + 0.5$	V
V_{IL}	Input LOW Voltage		-0.5		$V_{CC} \times 0.1$	V
V_{OL}	Output LOW Voltage	$I_{OL} = 3\text{mA}$			0.4	V

Capacitance

SYMBOL	TEST	TEST CONDITIONS	MAX	UNITS
$C_{I/O}$ (Note 4)	Input/Output Capacitance (SDA)	$V_{I/O} = 0\text{V}$	8	pF
C_{IN} (Note 4)	Input Capacitance (A0, A1, A2 and SCL)	$V_{IN} = 0\text{V}$	6	pF

NOTE:

4. This parameter is not 100% tested.

A.C. Test Conditions

Input Pulse Levels	$V_{CC} \times 0.1$ to $V_{CC} \times 0.9$
Input Rise and Fall Times	10ns
Input and Output Timing Level	$V_{CC} \times 0.5$

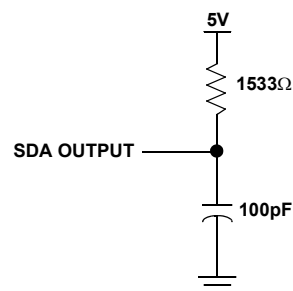
Equivalent A.C. Load Circuit**AC TIMING** Over recommended operating conditions

SYMBOL	PARAMETER	MIN	MAX	UNITS
f_{SCL}	Clock Frequency		400	kHz
t_{CYC}	Clock Cycle Time	2500		ns
t_{HIGH}	Clock High Time	600		ns
t_{LOW}	Clock Low Time	1300		ns
$t_{SU:STA}$	Start Setup Time	600		ns
$t_{HD:STA}$	Start Hold Time	600		ns
$t_{SU:STO}$	Stop Setup Time	600		ns
$t_{SU:DAT}$	SDA Data Input Setup Time	500		ns
$t_{HD:DAT}$	SDA Data Input Hold Time	50		ns
t_R (Note 2)	SCL and SDA Rise Time		300	ns
t_F (Note 2)	SCL and SDA Fall Time		300	ns
t_{AA} (Note 2)	SCL Low to SDA Data Output Valid Time		900	ns
t_{DH} (Note 2)	SDA Data Output Hold Time	50		ns
T_I (Note 2)	Noise Suppression Time Constant at SCL and SDA inputs	50		ns
t_{BUF} (Note 2)	Bus Free Time (Prior to Any Transmission)	1300		ns
$t_{SU:WPA}$	A0, A1 (Note 2)	0		ns
$t_{HD:WPA}$	A0, A1 (Note 2)	0		ns

DC Timing (Note 2)

SYMBOL	PARAMETER	MIN	MAX	UNITS
t_{WRPO}	Wiper Response Time After The Third (Last) Power Supply Is Stable		10	μs
t_{WRL}	Wiper Response Time After Instruction Issued (All Load Instructions)		10	μs
t_{WRID}	Wiper Response Time From An Active SCL Edge (Increment/Decrement Instruction)		10	μs

Timing Diagrams

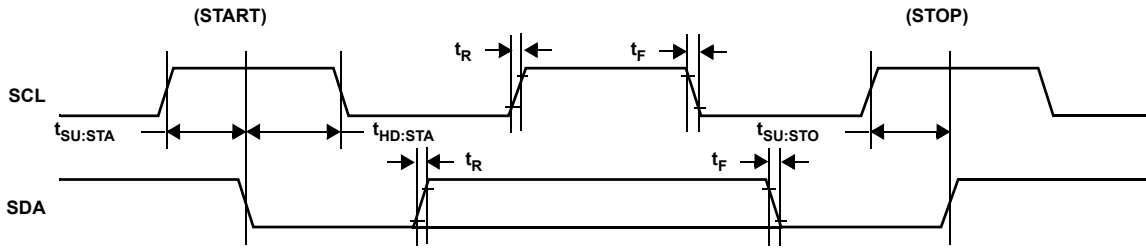

FIGURE 9. START AND STOP TIMING

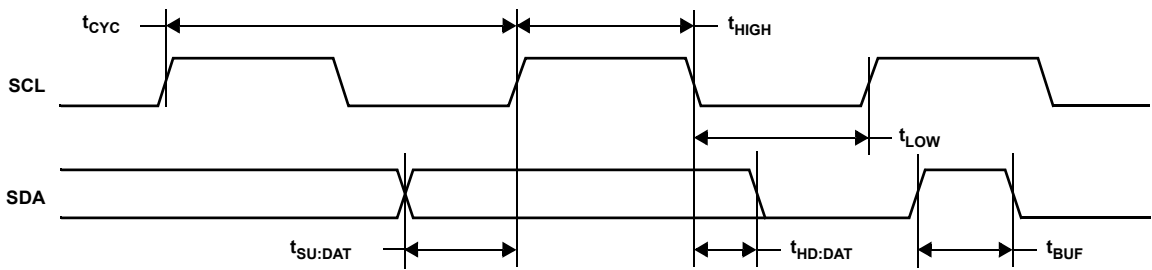

FIGURE 10. INPUT TIMING

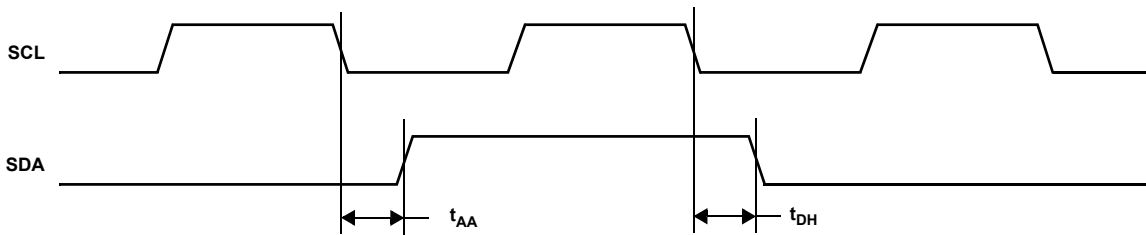

FIGURE 11. OUTPUT TIMING

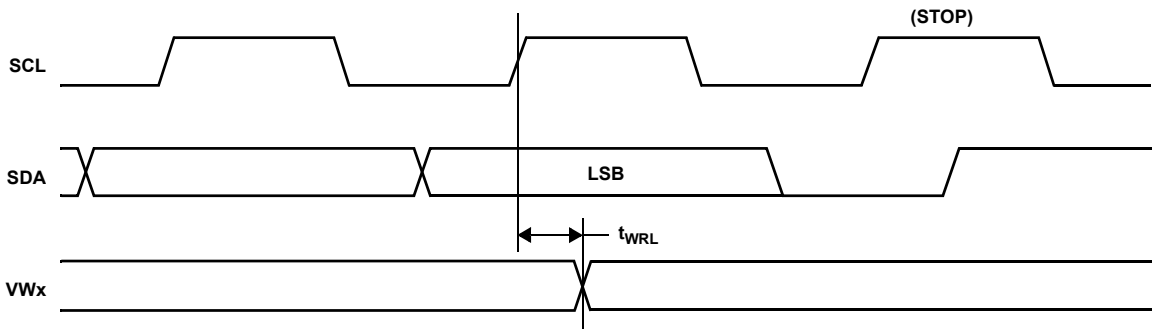

FIGURE 12. DCP TIMING (FOR ALL LOAD INSTRUCTIONS)

Typical Performance Characteristics

(V_{CC} , $V+$ = 5.0V, $V-$ = -5.0V, T_A = + 25 °C, unless otherwise noted)

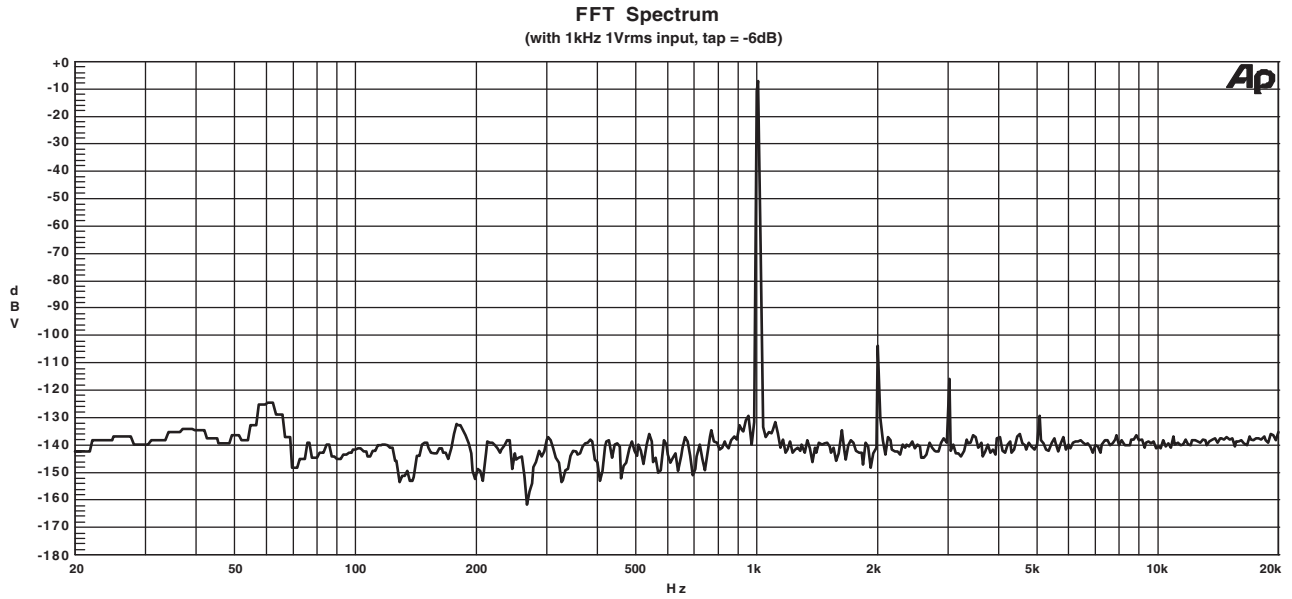

FIGURE 13. SINGLE TONE FREQUENCY RESPONSE

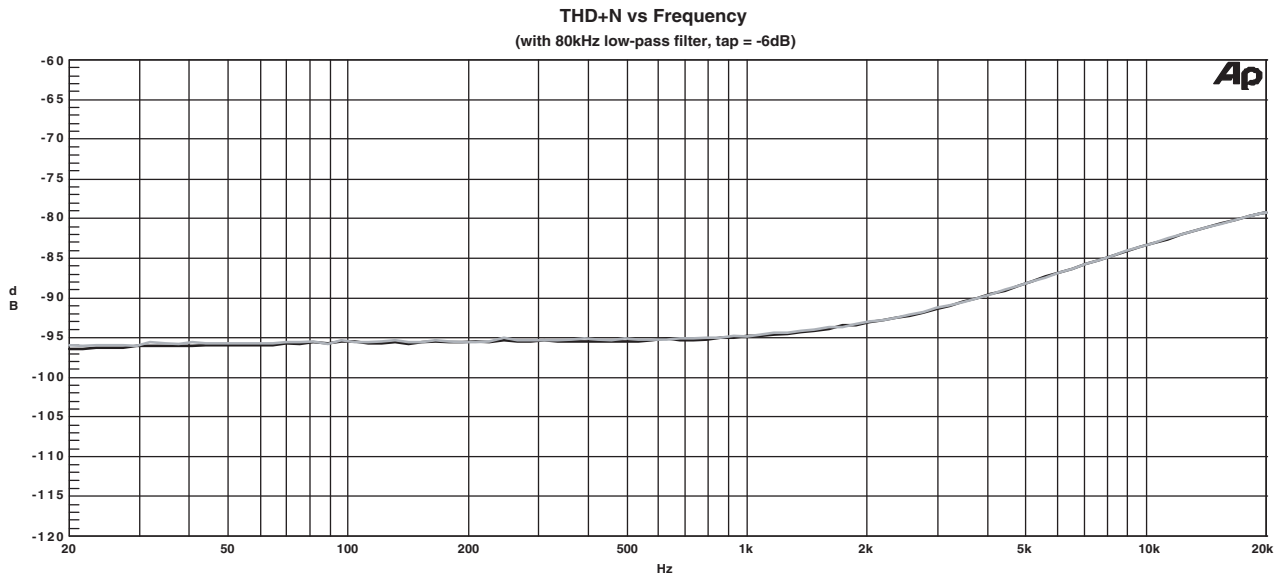

FIGURE 14. THD + N

Typical Performance Characteristics

(V_{CC} , $V+$ = 5.0V, $V-$ = -5.0V, T_A = + 25 °C, unless otherwise noted)

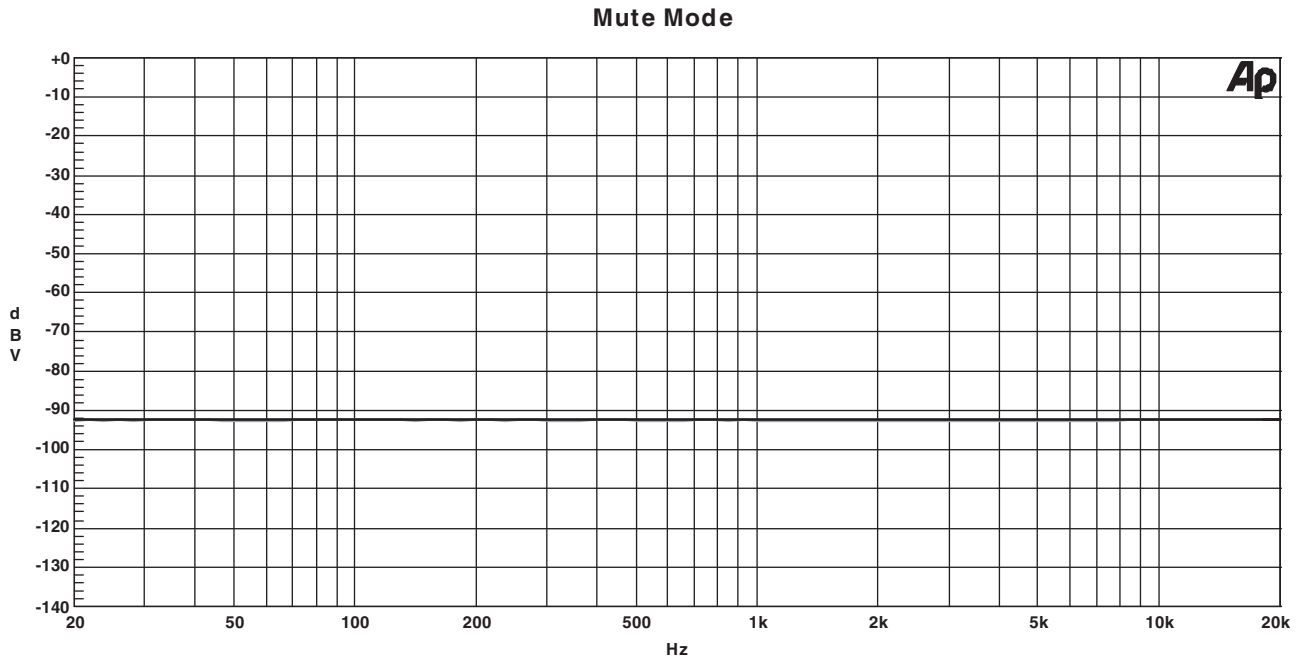

FIGURE 15. MUTE

© Copyright Intersil Americas LLC 2005-2013. All Rights Reserved.
 All trademarks and registered trademarks are the property of their respective owners.

For additional products, see www.intersil.com/en/products.html

Intersil products are manufactured, assembled and tested utilizing ISO9001 quality systems as noted
 in the quality certifications found at www.intersil.com/en/support/qualandreliability.html

Intersil products are sold by description only. Intersil may modify the circuit design and/or specifications of products at any time without notice, provided that such modification does not, in Intersil's sole judgment, affect the form, fit or function of the product. Accordingly, the reader is cautioned to verify that datasheets are current before placing orders. Information furnished by Intersil is believed to be accurate and reliable. However, no responsibility is assumed by Intersil or its subsidiaries for its use; nor for any infringements of patents or other rights of third parties which may result from its use. No license is granted by implication or otherwise under any patent or patent rights of Intersil or its subsidiaries.

For information regarding Intersil Corporation and its products, see www.intersil.com

Packaging Information

14-Lead Plastic, TSSOP, Package Type V

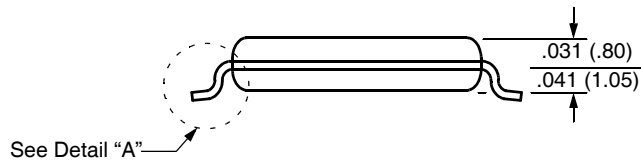
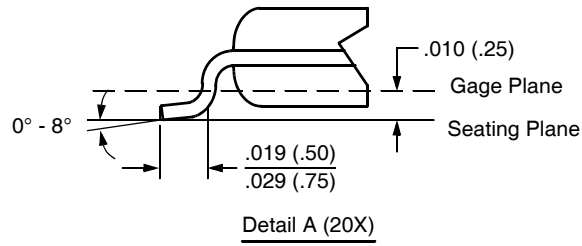
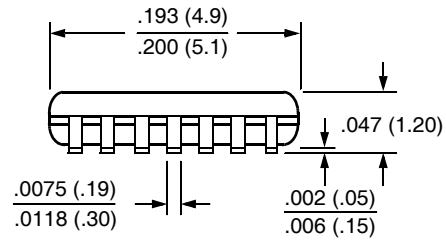
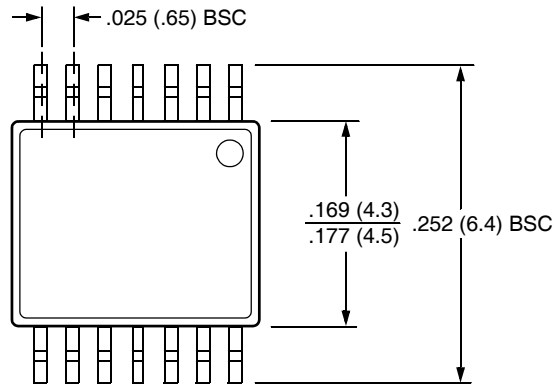

NOTE: ALL DIMENSIONS IN INCHES (IN PARENTHESES IN MILLIMETERS)