



Features

- Unit height of 2.9 mm
- Inductance range: 1500 to 10,000 μ H
- Rated current up to 0.12 A
- RoHS compliant*

Applications

- DC/DC converters
- Power supplies for:
 - Portable communication equipment
 - Laptop computers
 - Camcorders, HDTV

SRE6603 Series - Shielded SMD Power Inductors

Electrical Characteristics

Bourns Part No.	Inductance @ 100 KHz L (μ H) ± 20 %	Q (Ref.)	Test Freq. (KHz)	SRF (MHz) Typ.	DCR (Ω) Max.	I rms (A)	I sat (A)	**K -Factor
SRE6603-152M	1500	50	100	2	4.2	0.12	0.035	82
SRE6603-222M	2200	50	100	2	8.5	0.10	0.028	68
SRE6603-332M	3300	50	100	1	11	0.08	0.024	53
SRE6603-472M	4700	50	100	1	13.9	0.06	0.021	48
SRE6603-682M	6800	50	100	1	25	0.04	0.019	37
SRE6603-103M	10,000	50	100	0.8	32.8	0.02	0.017	31

**K-Factor: To calculate core flux density, B_{p-p} (gauss) = $K \times L(\mu H) \times \Delta I$ (peak-to-peak ripple current, A), determine core loss from *Core Loss vs. Flux Density* plot.

Core Loss vs. Flux Density

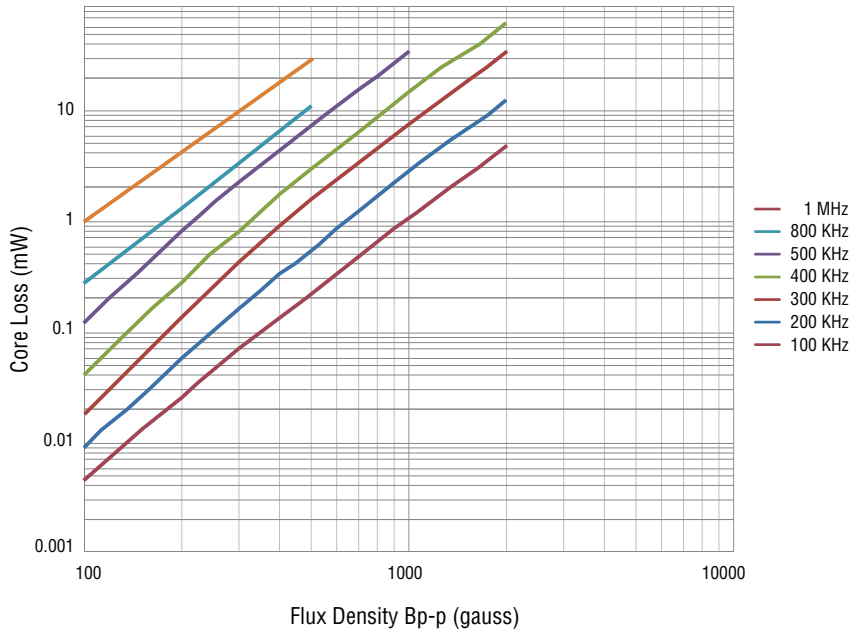

General Specifications

Test Voltage 0.1 V
 Reflow Soldering ... 230 °C, 50 sec max.
 Operating Temperature -25 °C to +105 °C
 (Temperature rise included)
 Storage Temperature -40 °C to +125 °C
 Resistance to Soldering Heat 260 °C for 10 sec.
 Moisture Sensitivity Level 1
 ESD Classification (HBM) N/A

Materials

Core Ferrite
 Wire Enameled copper
 Base Ceramic
 Adhesive Epoxy resin
 Terminal Ag/Ni/Au
 Rated Current Ind. drop of 30 % typ. at Isat
 Temperature Rise ... 40 °C typical at Irms
 Packaging 2000 pcs. per 13-inch reel

Product Dimensions

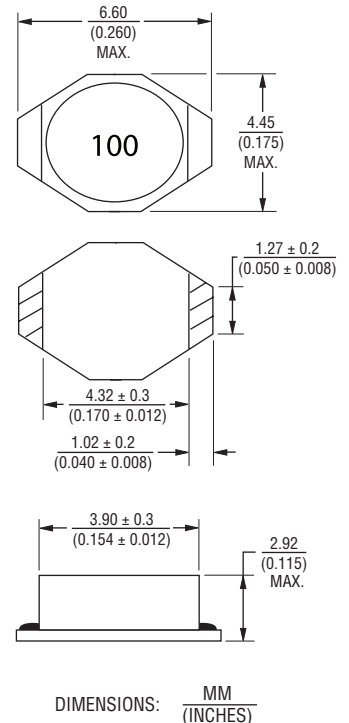

Schematic

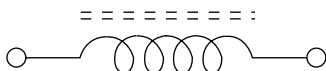

Recommended Layout

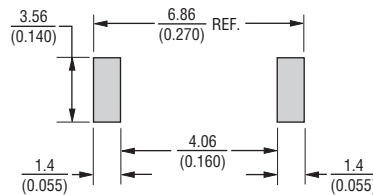

*RoHS Directive 2002/95/EC Jan. 27, 2003 including annex and RoHS Recast 2011/65/EU June 8, 2011.

Specifications are subject to change without notice.

The device characteristics and parameters in this data sheet can and do vary in different applications and actual device performance may vary over time.

Users should verify actual device performance in their specific applications.

SRE6603 Series - Shielded SMD Power Inductors

BOURNS®

Soldering Profile

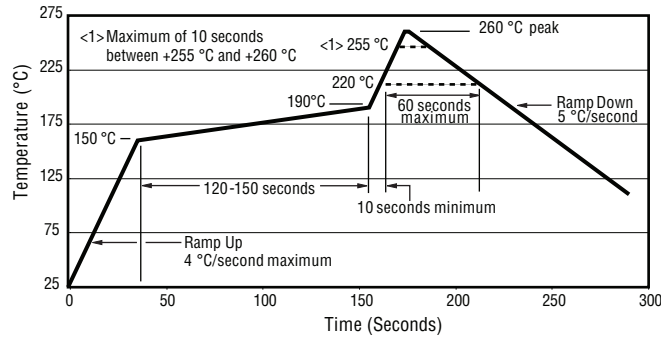

Packaging Specifications

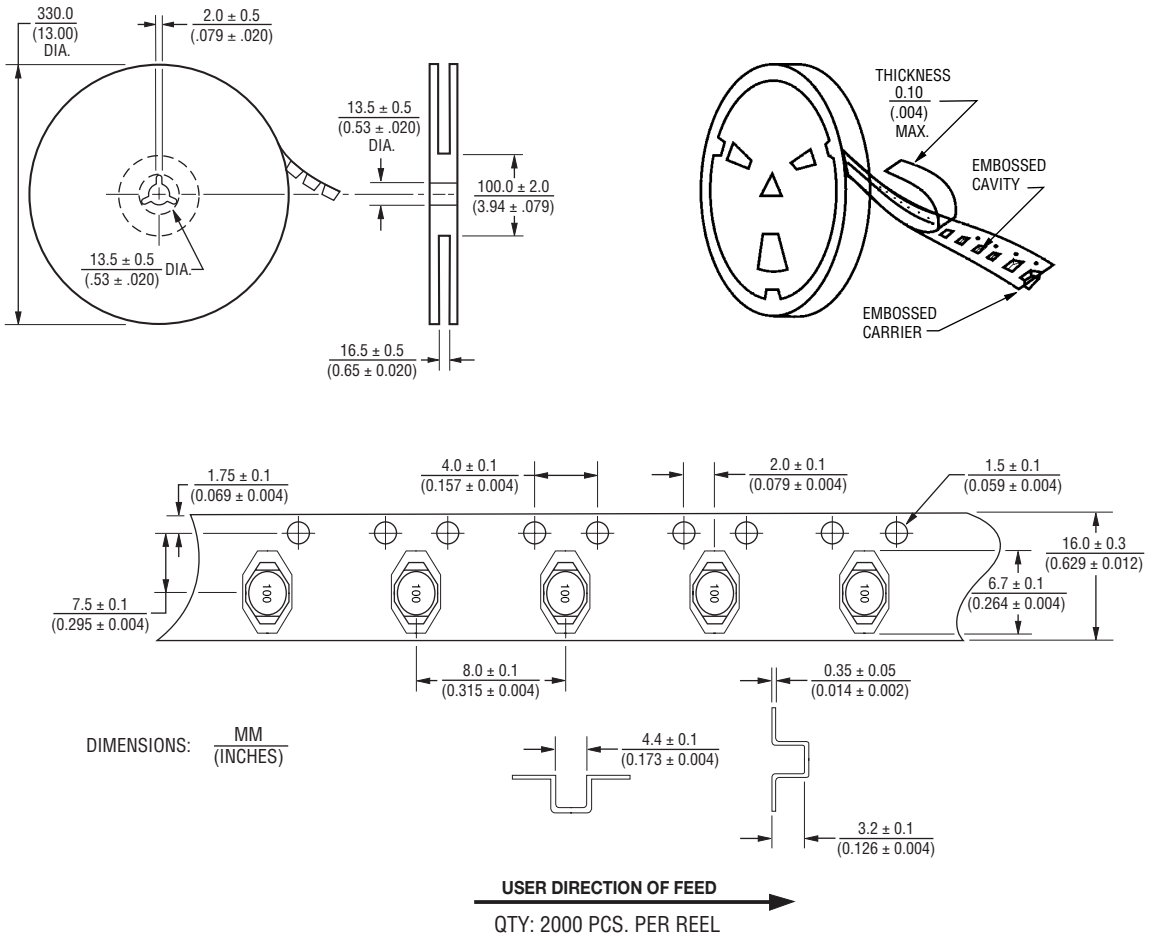

REV. 03/18

Specifications are subject to change without notice.

The device characteristics and parameters in this data sheet can and do vary in different applications and actual device performance may vary over time.

Users should verify actual device performance in their specific applications.