



Features

- Unit height of 2.9 mm
- Inductance range: 1 to 1000 μ H
- Rated current up to 2.9 A
- RoHS compliant*

Applications

- DC/DC converters
- Power supplies for:
 - Portable communication equipment
 - Laptop computers
 - Camcorders, HDTV

SDE6603 Series - SMD Power Inductors

Electrical Characteristics

Bourns Part No.	Inductance @ 100KHz L (μ H) ± 20 %	SRF (MHz) Typ.	DCR (Ω) Max.	I rms (A)	I sat (A)	**K-Factor
SDE6603-1R0M	1.0	130	0.05	2.9	2.9	1000
SDE6603-1R5M	1.5	115	0.06	2.8	2.6	867
SDE6603-2R2M	2.2	90	0.07	2.4	2.3	684
SDE6603-3R3M	3.3	70	0.08	2.0	2.0	520
SDE6603-4R7M	4.7	50	0.09	1.5	1.5	448
SDE6603-6R8M	6.8	45	0.13	1.4	1.2	371
SDE6603-100M	10	35	0.16	1.1	1.1	302
SDE6603-150M	15	30	0.23	1.0	0.9	245
SDE6603-220M	22	20	0.37	0.8	0.7	200
SDE6603-330M	33	15	0.51	0.6	0.58	160
SDE6603-470M	47	14	0.64	0.5	0.5	137
SDE6603-680M	68	11	0.86	0.4	0.4	70
SDE6603-101M	100	9	1.27	0.3	0.31	57
SDE6603-151M	150	6	2.0	0.25	0.27	45
SDE6603-221M	220	5.5	3.11	0.2	0.22	38
SDE6603-331M	330	5	3.8	0.16	0.18	30
SDE6603-471M	470	4	5.06	0.15	0.16	26
SDE6603-681M	680	3	9.2	0.12	0.14	22
SDE6603-102M	1000	2	13.8	0.07	0.1	18

**K-Factor: To calculate core flux density, Bp-p (gauss) = K x L(μ H) x Δ I (peak-to-peak ripple current, A), determine core loss from *Core Loss vs. Flux Density* plot.

Core Loss vs. Flux Density

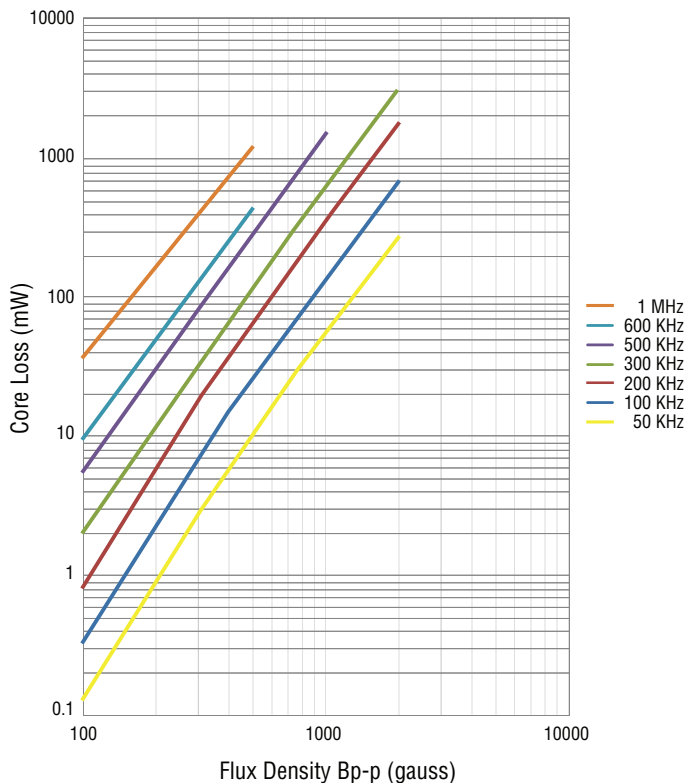

The device characteristics and parameters in this data sheet can and do vary in different applications and actual device performance may vary over time. Users should verify actual device performance in their specific applications.

General Specifications

Test Voltage 0.1 V
 Reflow Soldering 230 °C, 50 sec max.
 Operating Temperature... -25 °C to +105 °C
 (Temperature rise included)
 Storage Temperature..... -40 °C to +125 °C
 Resistance to Soldering Heat
 260 °C for 10 sec.
 Moisture Sensitivity Level 1
 ESD Classification (HBM)..... N/A

Materials

Core Ferrite
 Wire Enameled copper
 Base Ceramic
 Adhesive Epoxy resin
 Terminal Ag/Ni/Au
 Rated Current.. Ind. drop of 10 % typ. at Isat
 Temperature Rise 40 °C typical at I rms
 Packaging 2000 pcs. per 13-inch reel

Product Dimensions

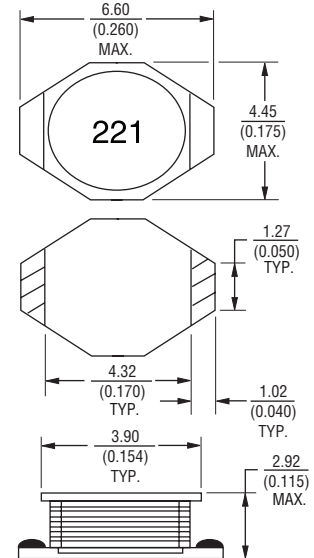

Recommended Layout

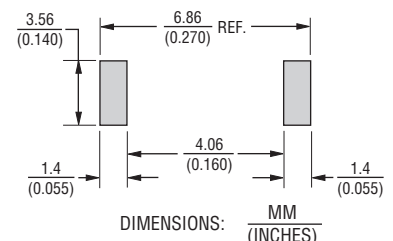

*RoHS Directive 2002/95/EC Jan. 27, 2003 including annex and RoHS Recast 2011/65/EU June 8, 2011. Specifications are subject to change without notice.

SDE6603 Series - SMD Power Inductors



Soldering Profile

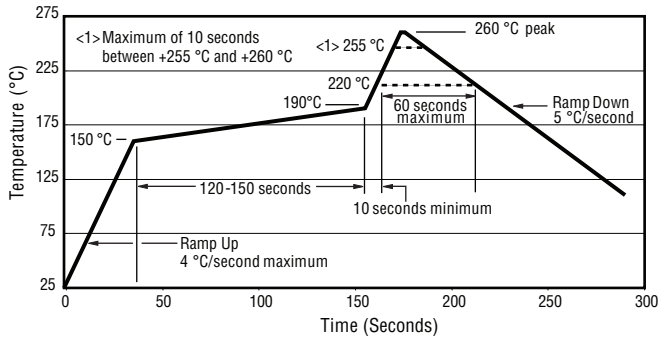

Schematic

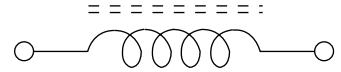

How to Order

Model **SDE6603 - 100M**
 Value Code (see table)

Packaging Specifications

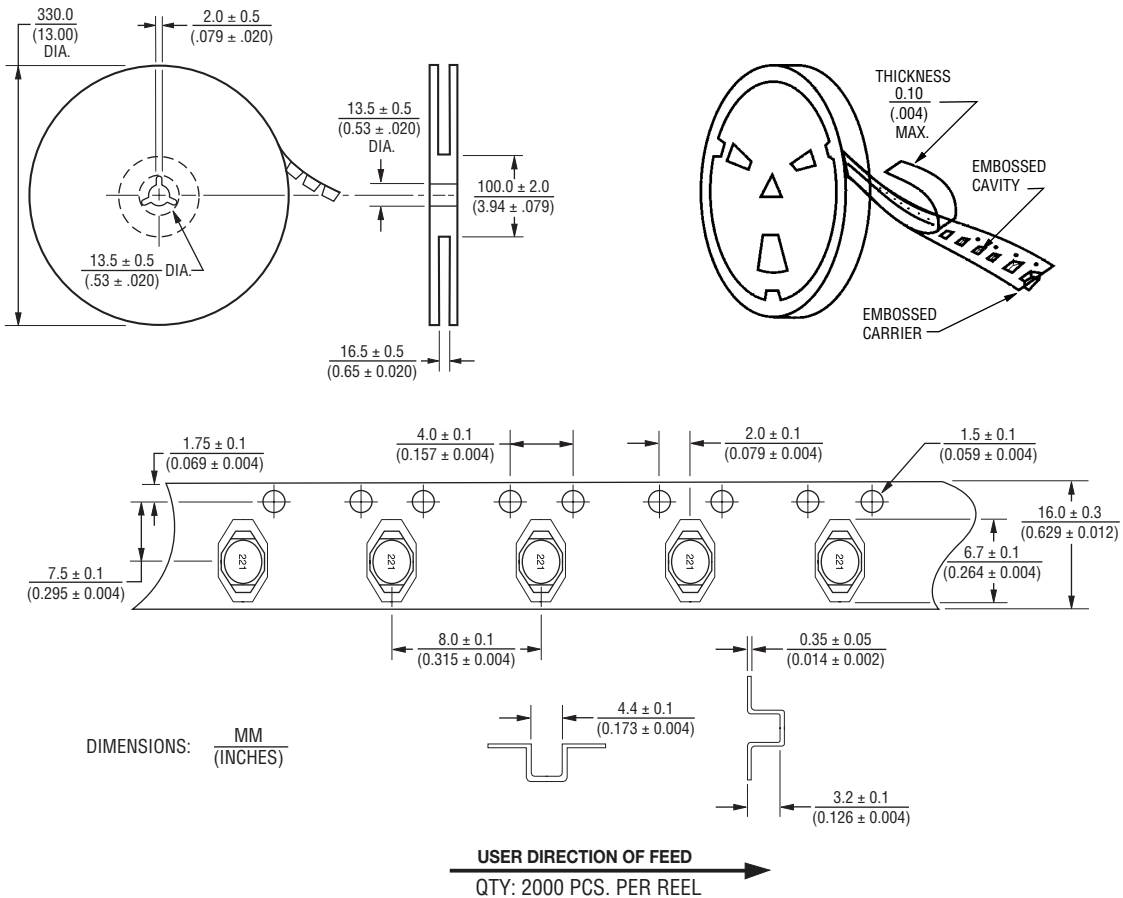

REV. 03/18

Specifications are subject to change without notice.
 The device characteristics and parameters in this data sheet can and do vary in different applications and actual device performance may vary over time.
 Users should verify actual device performance in their specific applications.