

Features

- Formerly **J. W. Miller**® model
- Shielded construction
- Unit height of 4.2 mm
- Inductance range: 0.15 μ H to 2.5 μ H
- Current up to 34 A
- RoHS compliant*



This series is currently available, but not recommended for new designs. Newer [Model SRP1038A](#) is recommended.

PM1038S Series - Shielded Power Inductors

Electrical Specifications

Bourns Part No.	Inductance L (μ H)	I rms (A)	I sat (A)	DCR (m Ω) max.
PM1038S-R15M-RC	0.15	34	40	1.3
PM1038S-R39M-RC	0.39	24	32	1.4
PM1038S-R50M-RC	0.50	23	32	1.9
PM1038S-R75M-RC	0.75	22	28	2.5
PM1038S-1R2M-RC	1.2	18	24	4.7
PM1038S-1R7M-RC	1.7	15	18	7.5
PM1038S-2R5M-RC	2.5	11.5	14	8.7

Soldering Profile

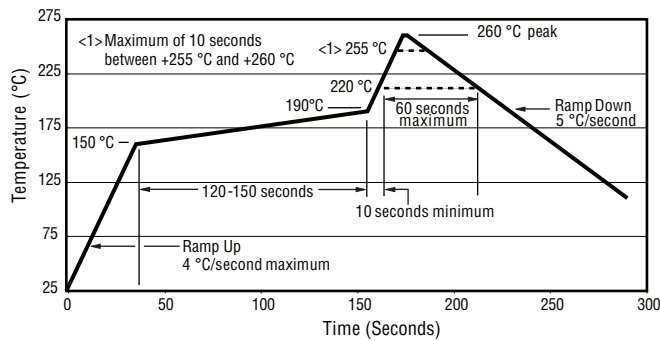

Electrical Schematic

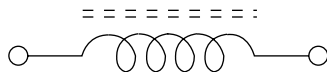

General Specifications

Test Voltage 0.25 V
 Test Frequency 100 KHz
 Reflow Soldering 230 °C; 50 sec max.
 Operating Temperature -55 °C to +150 °C
 (Temperature rise included)
 Storage Temperature -55 °C to +150 °C
 Resistance to Soldering Heat +260 °C for 10 sec.
 Moisture Sensitivity Level 1
 ESD Classification (HBM) N/A

Materials

Core Iron Wire
 Wire Enameled copper
 Terminal Cu/Sn
 Rated Current Ind. drops 20 % at I sat
 Temperature Rise 40 °C at rated I rms
 Packaging 800 pcs. per 13-inch reel

Product Dimensions

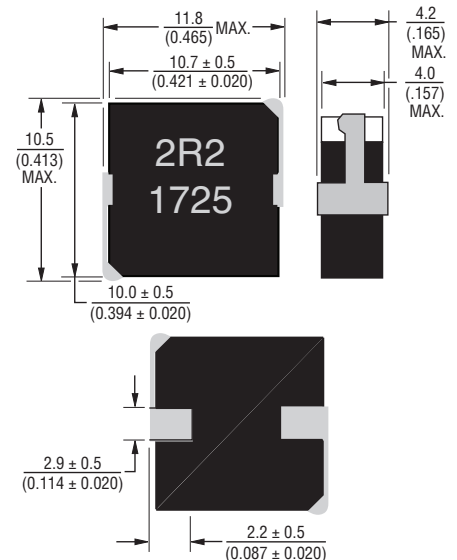

Recommended Layout

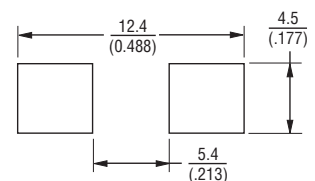

DIMENSIONS: $\frac{\text{MM}}{\text{(INCHES)}}$

*RoHS Directive 2002/95/EC Jan. 27, 2003 including annex and RoHS Recast 2011/65/EU June 8, 2011. Specifications are subject to change without notice.

The device characteristics and parameters in this data sheet can and do vary in different applications and actual device performance may vary over time. Users should verify actual device performance in their specific applications.

Applications

- Input/output of DC/DC converters
- Power supplies for:
 - Portable communication equipment
 - Camcorders
 - LCD TVs

PM1038S Series - Shielded Power Inductors

BOURNS®

L vs. I Charts

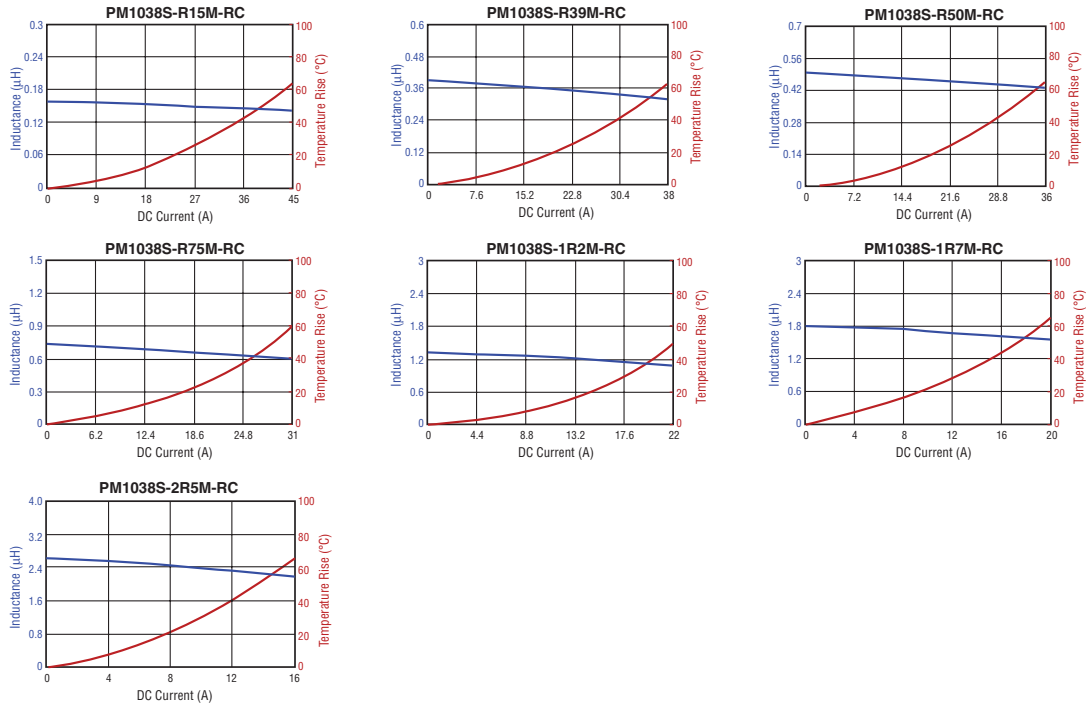

Packaging Specifications

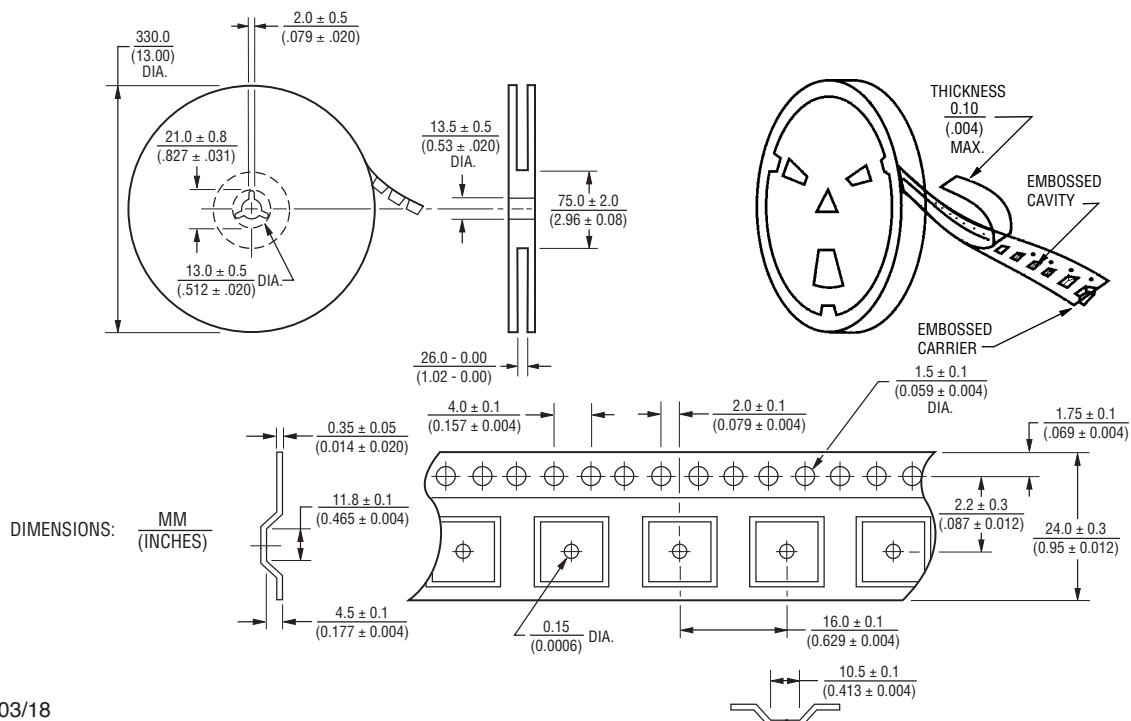

REV. 03/18

Specifications are subject to change without notice.

The device characteristics and parameters in this data sheet can and do vary in different applications and actual device performance may vary over time. Users should verify actual device performance in their specific applications.