

869911CS
(DRAWING NO.) 台異異図

版数 VER.	年月日 DATE	CN NO.	変更内容 DESCRIPTION	製図 DR.	担当 CHK.	査閲 APPD.	承認 APPD.
2	04/JAN/2017	019866	CORRECTION OF ERROR 誤記訂正	—	K. NAKAZAWA	—	T. KUDOU
3	26/APR/2017	021195	ADDITION OF CONTACT NO. 端子番号追加 CORRECTION OF ERRORS 誤記訂正	—	K. NAKAZAWA	—	T. KUDOU
4	09/APR/2018	023696	CHANGE OF APPLICABLE CABLE 適用電線変更	—	K. NAKAZAWA	—	T. KUDOU

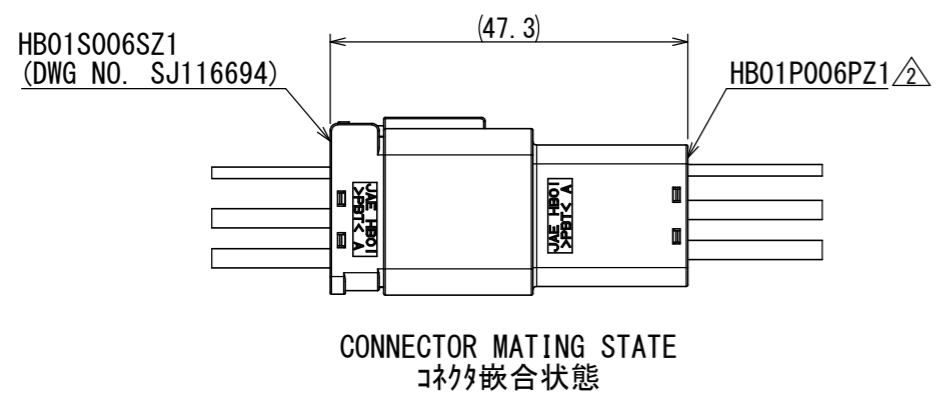
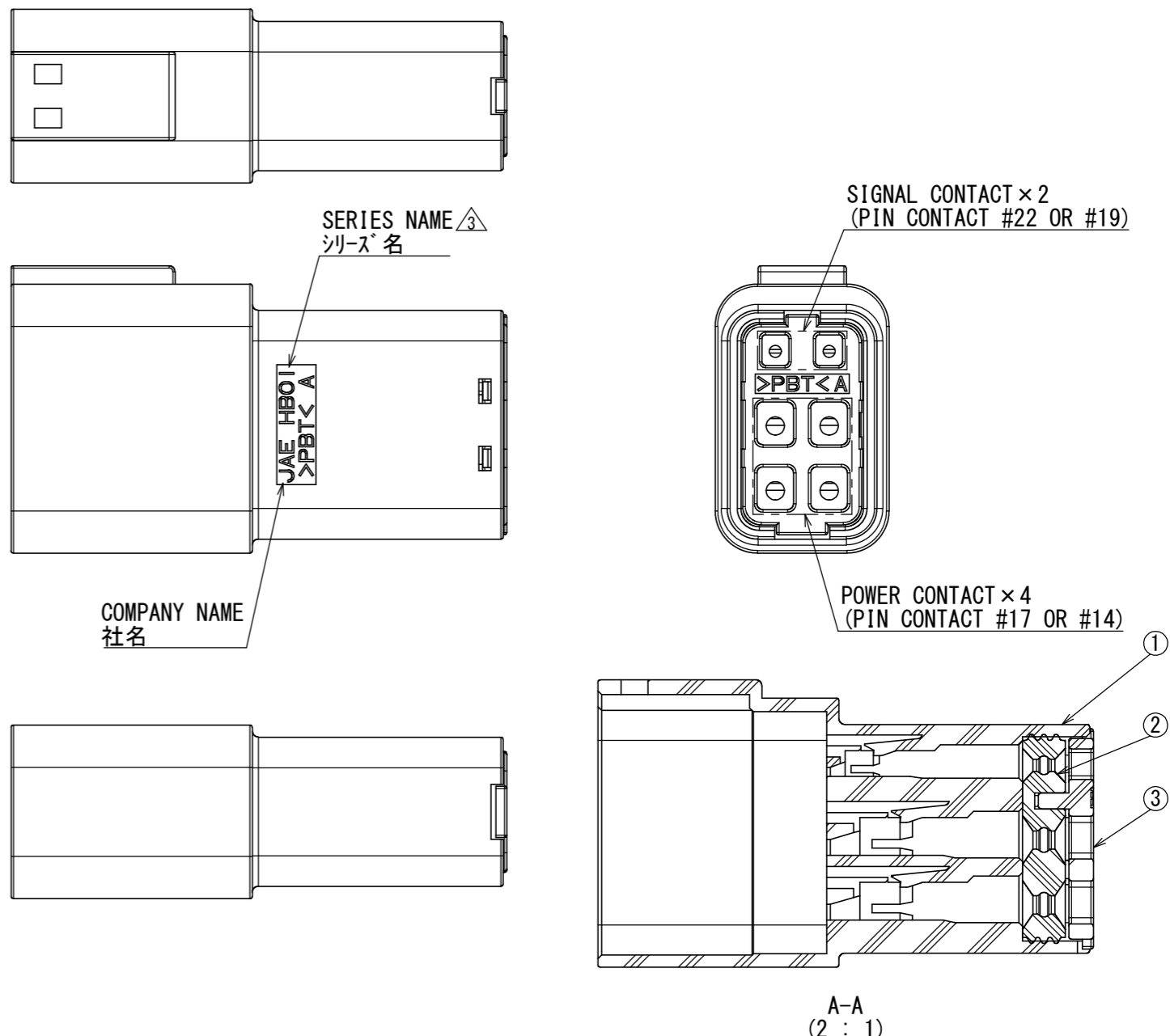
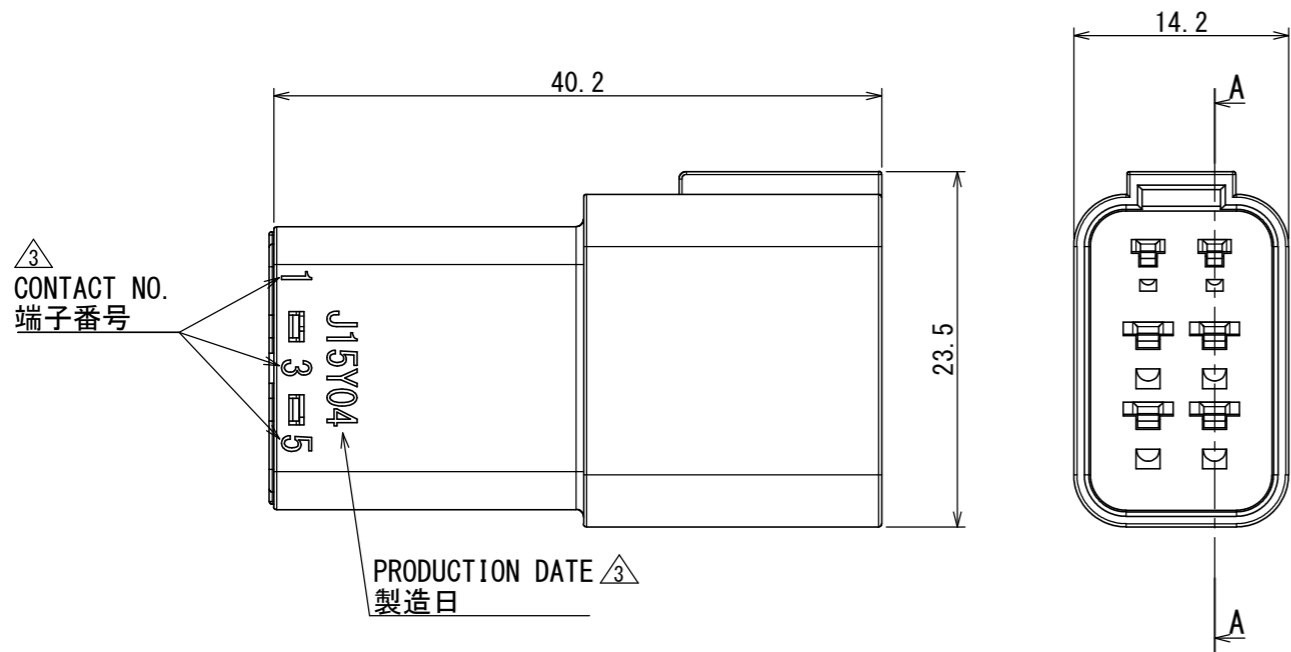

NOTE 1. APPLICABLE CONTACTS ARE SHOWN.
THE CONTACTS ARE SOLD SEPARATELY. (REFER TO TABLE 1)
注1. 適用コネクタを示す。コネクタは別売りである。(表1参照)

TABLE 1. APPLICABLE CONTACTS (NOTE 1)

NO.	PRODUCT NAME 名称	DRAWING NO. 図番	CONTACT TYPE コネクタ種別	APPLICABLE CABLE 適用電線	
				WIRE SIZE 電線サイズ	INSULATION DIA. 被覆外径
1	HB01P06K4P1	SJ116695	PIN CONTACT #22	AWG#22~24	φ1.1~1.5 ^{△3}
2	HB01P06K4P2	SJ116696	PIN CONTACT #19	AWG#19~21	φ1.2~1.8
3	HB01P25H3P1	SJ116699	PIN CONTACT #17	AWG#17~19	φ1.6~2.3
4	HB01P25H2P1	SJ116700	PIN CONTACT #14	AWG#14~16	φ2.1~2.95 ^{△4}

符号 NO.	名称 DESCRIPTION	個数 QTY.	材料 MATERIAL	仕上 FINISH	備考 REMARKS
3	COVER	1	PBT	COLOR: NATURAL	—
2	GROMMET	1	SILICONE RUBBER	COLOR: BROWN	—
1	INSULATOR	1	PBT	COLOR: BLACK	—

仕様書 (SPECIFICATION) JACS-11114 (-*)		第1版 (ORIGINAL DATE) 04/DEC/2015		尺度 (SCALE) 2:1		シリーズ (SERIES) HB01		日本航空電子工業株式会社	
一般公差 (GENERAL TOLERANCE)		製図 DR.		名称 (TITLE)		HB01P006PZ1		JAE	
寸法 (DIMENSION)		担当 CHK.		品質 (MASS)		7.5g		JAPAN AVIATION ELECTRONICS INDUSTRY, LTD.	
角度 (ANGLES)		査閲 APPD.		図面番号 (DRAWING NO.)		SJ116693		版数 (VER.)	
単位 (UNIT) : mm		承認 APPD.		T. KUDOU				4	

DCF-C-212H(12.08)

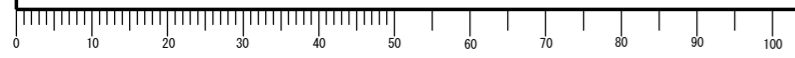

WISDOM承認 2018/04/12