

E L2276

70MHz/1mA Current Mode Feedback Amp w/Disable

FN7054
 Rev 1.00
 May 6, 2005

The EL2276 is a dual current-feedback operational amplifier which achieves a -3dB bandwidth of 70MHz at a gain of +1 while consuming only 1mA of supply current per amplifier. It will operate with dual supplies ranging from $\pm 1.5V$ to $\pm 6V$, or from single supplies ranging from +3V to +12V. The EL2276 also includes a disable/power-down feature which reduces current consumption to 0mA while placing the amplifier output in a high impedance state. In spite of its low supply current, the EL2276 can output 55mA while swinging to $\pm 4V$ on $\pm 5V$ supplies. These attributes make the EL2276 excellent choice for low power and/or low voltage cable-driver, HDSL, or RGB applications.

Ordering Information

PART NUMBER	PACKAGE	TAPE & REEL	PKG. DWG. #
EL2276CS	14-Pin SOIC	-	MDP0027
EL2276CS-T7	14-Pin SOIC	7"	MDP0027
EL2276CS-T13	14-Pin SOIC	13"	MDP0027
EL2276CSZ (See Note)	14-Pin SOIC (Pb-free)	-	MDP0027
EL2276CSZ-T7 (See Note)	14-Pin SOIC (Pb-free)	7"	MDP0027
EL2276CSZ-T13 (See Note)	14-Pin SOIC (Pb-free)	13"	MDP0027

NOTE: Intersil Pb-free products employ special Pb-free material sets; molding compounds/die attach materials and 100% matte tin plate termination finish, which are RoHS compliant and compatible with both SnPb and Pb-free soldering operations. Intersil Pb-free products are MSL classified at Pb-free peak reflow temperatures that meet or exceed the Pb-free requirements of IPC/JEDEC J STD-020.

Features

- Dual topology
- 1mA supply current (per amplifier)
- 70MHz -3dB bandwidth
- Low cost
- Fast disable
- Powers down to 0mA
- Single- and dual-supply operation down to $\pm 1.5V$
- 0.15%/0.15° diff. gain/diff. phase into 150 Ω
- 800V/ μs slew rate
- Large output drive current: 55mA
- Pb-Free available (RoHS compliant)

Applications

- Low power/battery applications
- HDSL amplifiers
- Video amplifiers
- Cable drivers
- RGB amplifiers
- Test equipment amplifiers
- Current to voltage converters

Pinout

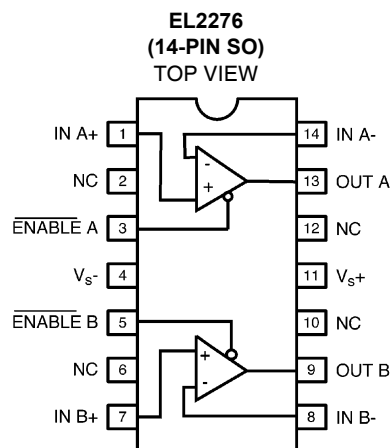

Manufactured under U.S. Patent No. 5,352,989, 5,351,012, 5,418,495

Absolute Maximum Ratings ($T_A = 25^\circ\text{C}$)

Voltage between V_{S+} and V_{S-} +12.6V
 Common-Mode Input Voltage V_{S-} to V_{S+}
 Differential Input Voltage $\pm 6\text{V}$
 Current into +IN or -IN $\pm 7.5\text{mA}$
 Internal Power Dissipation See Curves

Operating Ambient Temperature Range -40°C to $+85^\circ\text{C}$
 Operating Junction Temperature Plastic Packages 150°C
 Output Current (EL2276) $\pm 60\text{mA}$
 Storage Temperature Range -65°C to $+150^\circ\text{C}$

CAUTION: Stresses above those listed in "Absolute Maximum Ratings" may cause permanent damage to the device. This is a stress only rating and operation of the device at these or any other conditions above those indicated in the operational sections of this specification is not implied.

IMPORTANT NOTE: All parameters having Min/Max specifications are guaranteed. Typical values are for information purposes only. Unless otherwise noted, all tests are at the specified temperature and are pulsed tests, therefore: $T_J = T_C = T_A$

DC Electrical Specifications $V_S = \pm 5\text{V}$, $R_L = 150\Omega$, $\overline{\text{ENABLE}} = 0\text{V}$, $T_A = 25^\circ\text{C}$ unless otherwise specified.

PARAMETER	DESCRIPTION	CONDITIONS	MIN	TYP	MAX	UNITS
V_{OS}	Input Offset Voltage			2.5	15	mV
TCV_{OS}	Average Input Offset Voltage Drift	Measured from T_{MIN} to T_{MAX}		5		$\mu\text{V}/^\circ\text{C}$
dV_{OS}	V_{OS} Matching			0.5		mV
$+I_{IN}$	+ Input Current			0.5	5	μA
$d+I_{IN}$	$+I_{IN}$ Matching			20		nA
$-I_{IN}$	- Input Current			4	15	μA
$d-I_{IN}$	$-I_{IN}$ Matching			1.5		μA
CMRR	Common Mode Rejection Ratio	$V_{CM} = \pm 3.5\text{V}$	45	50		dB
-ICMR	- Input Current Common Mode Rejection	$V_{CM} = \pm 3.5\text{V}$		4	10	$\mu\text{A}/\text{V}$
PSRR	Power Supply Rejection Ratio	V_S is moved from $\pm 4\text{V}$ to $\pm 6\text{V}$	60	70		dB
-IPSR	- Input Current Power Supply Rejection	V_S is moved from $\pm 4\text{V}$ to $\pm 6\text{V}$		0.5	5	$\mu\text{A}/\text{V}$
R_{OL}	Transimpedance	$V_{OUT} = \pm 2.5\text{V}$	150	400		$\text{k}\Omega$
$+R_{IN}$	+ Input Resistance	$V_{CM} = \pm 3.5\text{V}$	1	4		$\text{M}\Omega$
$+C_{IN}$	+ Input Capacitance			1.2		pF
CMIR	Common Mode Input Range		± 3.5	± 4.0		V
V_O	Output Voltage Swing	$V_S = \pm 5$	± 3.5	± 4.0		V
		$V_S = +5$ Single-Supply, High		4.0		V
		$V_S = +5$ Single-Supply, Low		0.3		V
I_O	Output Current	Per Amplifier	50	55		mA
I_S	Supply Current	$\overline{\text{ENABLE}} = 2.0\text{V}$, per Amplifier		1	2	mA
$I_{S(DIS)}$	Supply Current (Disabled)	$\overline{\text{ENABLE}} = 4.5\text{V}$		0	20	μA
$C_{OUT(DIS)}$	Output Capacitance (Disabled)	$\overline{\text{ENABLE}} = 4.5\text{V}$		4.4		pF
R_{EN}	Enable Pin Input Resistance	Measured at $\overline{\text{ENABLE}} = 2.0\text{V}$, 4.5V	45	85		$\text{k}\Omega$
I_{IH}	Logic "1" Input Current	Measured at $\overline{\text{ENABLE}}$, $\overline{\text{ENABLE}} = 4.5\text{V}$		-0.04		μA
I_{IL}	Logic "0" Input Current	Measured at $\overline{\text{ENABLE}}$, $\overline{\text{ENABLE}} = 0\text{V}$		-53		μA
V_{DIS}	Minimum Voltage at $\overline{\text{ENABLE}}$ to Disable		4.5			V
V_{EN}	Maximum Voltage at $\overline{\text{ENABLE}}$ to Enable				2.0	V

AC Electrical Specifications $V_S = \pm 5V$, $R_F = R_G = 1.0k\Omega$, $R_L = 150\Omega$, $\overline{ENABLE} = 0V$, $T_A = 25^\circ C$ unless otherwise specified.

PARAMETER	DESCRIPTION	CONDITIONS	MIN	TYP	MAX	UNITS
-3dB BW	-3dB Bandwidth	$A_V = +1$		70		MHz
-3dB BW	-3dB Bandwidth	$A_V = +2$		60		MHz
SR	Slew Rate	$V_{OUT} = \pm 2.5V$, $A_V = +2$	400	800		V/ μs
t_R , t_F	Rise and Fall Time	$V_{OUT} = \pm 500mV$		4.5		ns
t_{PD}	Propagation Delay	$V_{OUT} = \pm 50mV$		4.5		ns
OS	Overshoot	$V_{OUT} = \pm 500mV$		3.0		%
t_s	0.1% Settling	$V_{OUT} = \pm 2.5V$, $A_V = -1$		40		ns
dG	Differential Gain	$A_V = +2$, $R_L = 150\Omega$ (Note 1)		0.15		%
dP	Differential Phase	$A_V = +2$, $R_L = 150\Omega$ (Note 1)		0.15		°
dG	Differential Gain	$A_V = +1$, $R_L = 500\Omega$ (Note 1)		0.02		%
dP	Differential Phase	$A_V = +1$, $R_L = 500\Omega$ (Note 1)		0.01		°
t_{ON}	Turn-On Time	$A_V = +2$, $V_{IN} = +1V$, $R_L = 150\Omega$ (Note 2)		40	100	ns
t_{OFF}	Turn-Off Time	$A_V = +2$, $V_{IN} = +1V$, $R_L = 150\Omega$ (Note 2)		1500	2000	ns
CS	Channel Separation	$f = 5MHz$		85		dB

NOTES:

1. DC offset from 0V to 0.714V, AC amplitude 286mV_{p-p}, $f = 3.58MHz$.
2. Measured from the application of the logic signal until the output voltage is at the 50% point between initial and final values.

Test Circuit (per Amplifier)

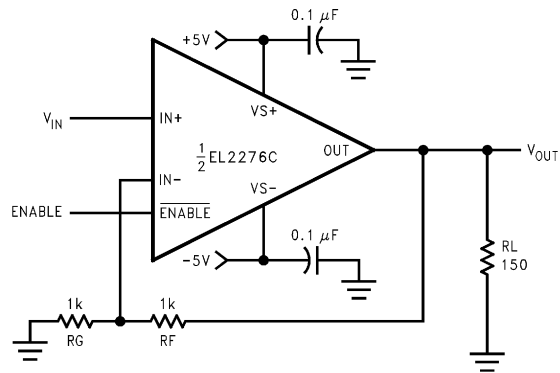

Simplified Schematic (per Amplifier)

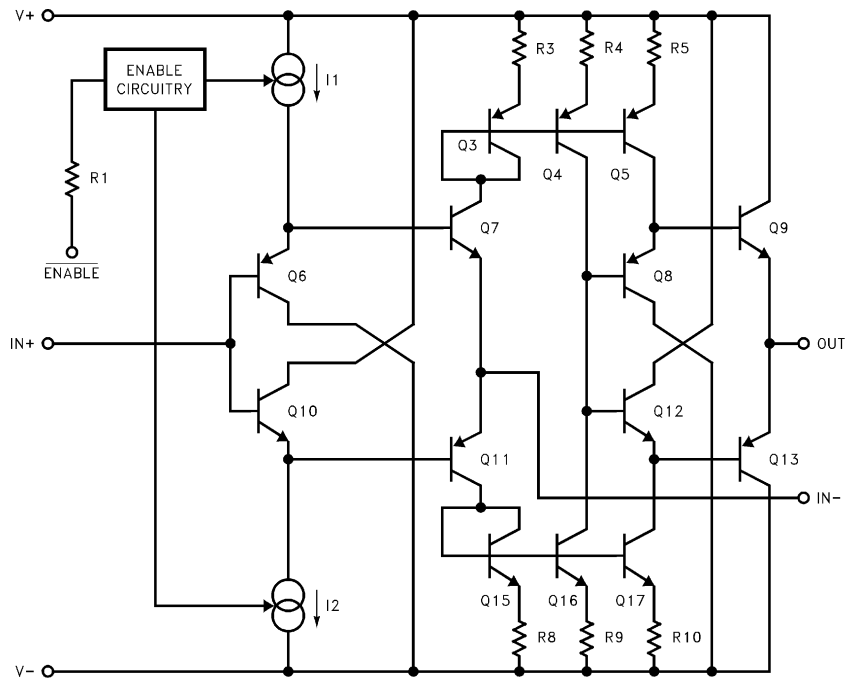

Typical Performance Curves

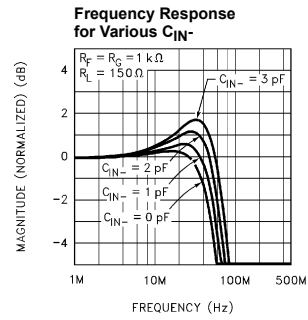
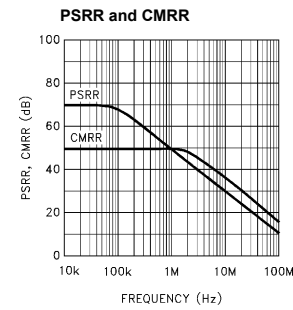
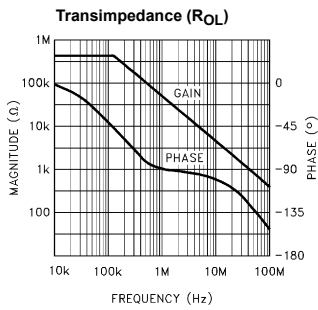
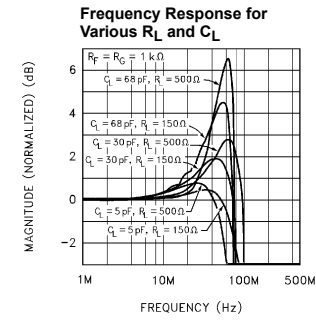
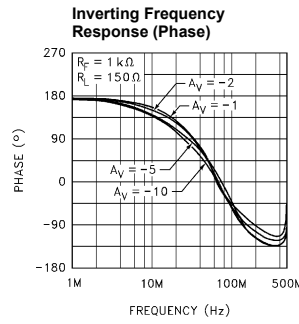
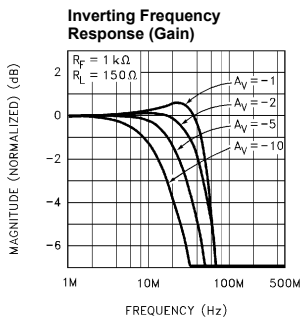
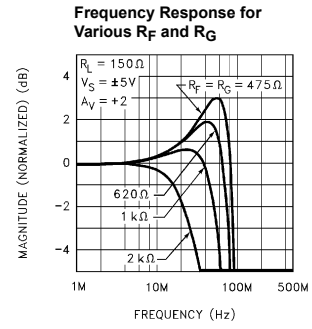
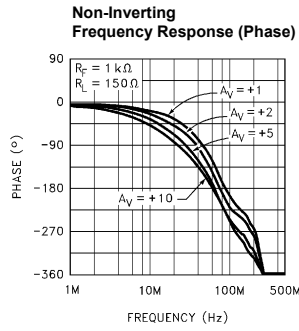
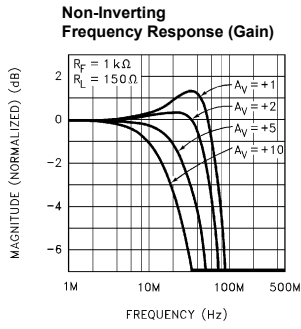

Typical Performance Curves (Continued)

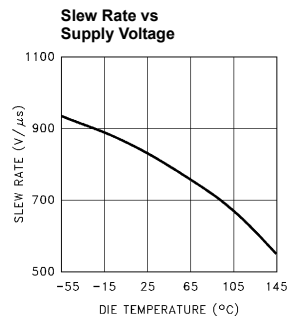
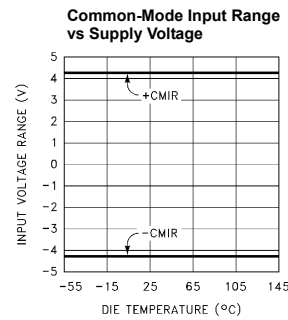
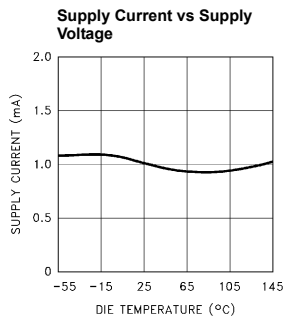
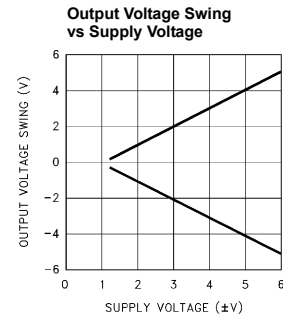
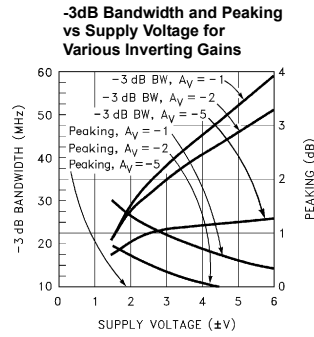
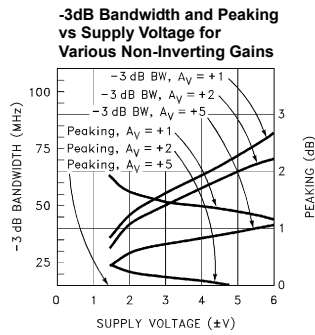
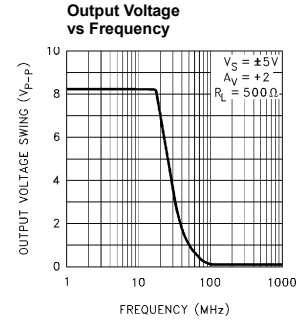
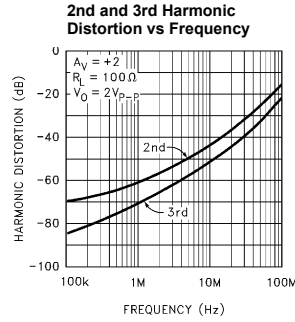
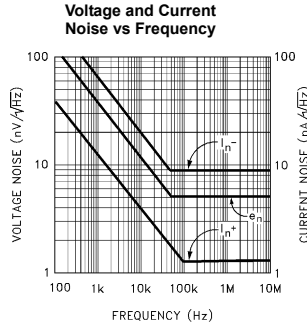

Typical Performance Curves (Continued)

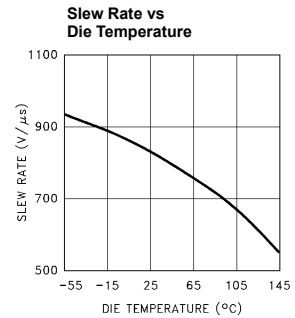
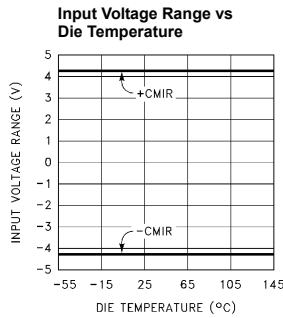
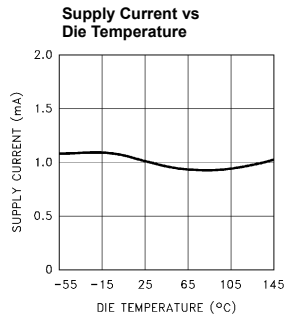
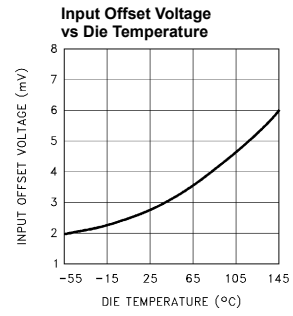
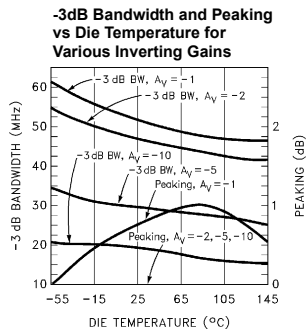
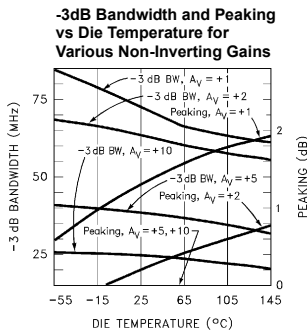
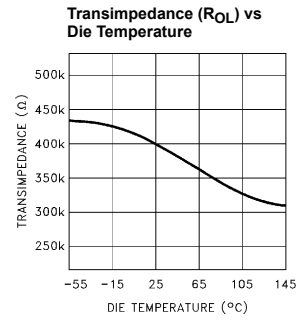
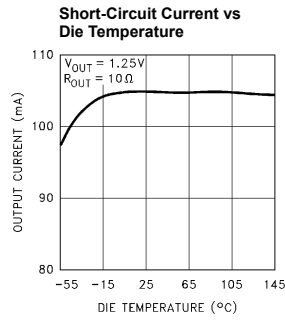
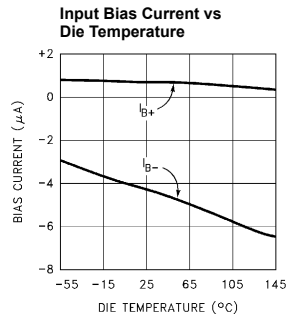

Typical Performance Curves (Continued)

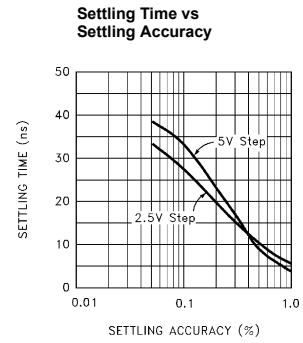
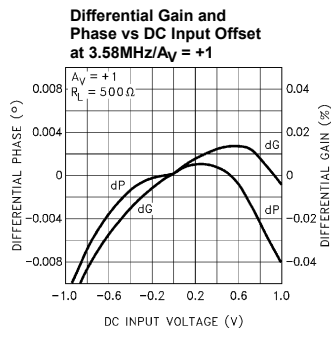
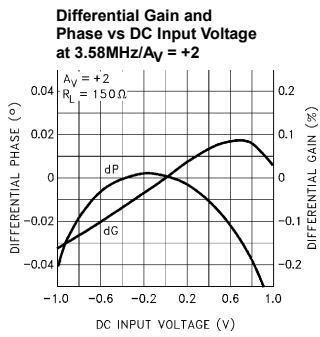

Small-Signal Step Response

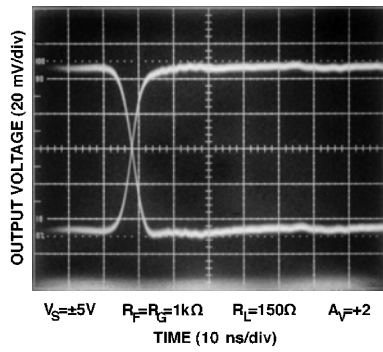

Large-Signal Step Response

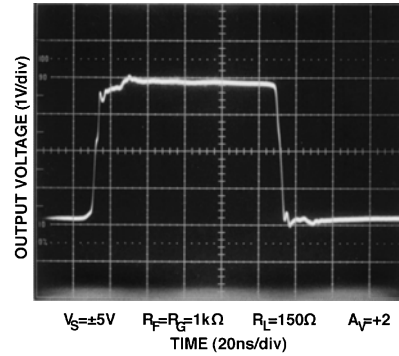

**14-Pin SO
Maximum Power Dissipation
vs Ambient Temperature**

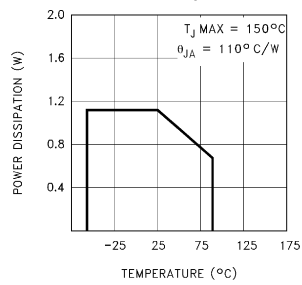

**Channel Separation
vs Frequency**

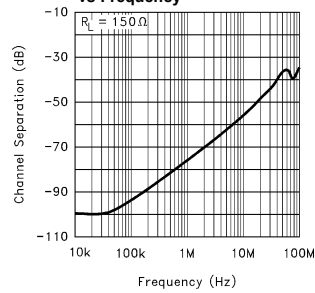

Applications Information

Product Description

The EL2276 is a current-feedback operational amplifier that offers a wide -3dB bandwidth of 70MHz, a low supply current of 1mA per amplifier and the ability to disable to 0mA. This product also features high output current drive. The EL2276 can output 55mA per amplifier. The EL2276 works with supply voltages ranging from a single 3V to $\pm 6V$, and it is also capable of swinging to within 1V of either supply on the input and the output. Because of its current-feedback topology, the EL2276 does not have the normal gain-bandwidth product associated with voltage-feedback operational amplifier. This allows its -3dB bandwidth to remain relatively constant as closed-loop gain is increased. This combination of high bandwidth and low power, together with aggressive pricing make the EL2276 the ideal choice for many low-power/high-bandwidth applications such as portable computing, HDSL, and video processing.

Power Supply Bypassing and Printed Circuit Board Layout

As with any high-frequency device, good printed circuit board layout is necessary for optimum performance. Ground plane construction is highly recommended. Lead lengths should be as short as possible. The power supply pins must be well bypassed to reduce the risk of oscillation. The combination of a 4.7 μF tantalum capacitor in parallel with a 0.1 μF capacitor has been shown to work well when placed at each supply pin.

For good AC performance, parasitic capacitance should be kept to a minimum especially at the inverting input (see the Capacitance at the Inverting Input section). Ground plane construction should be used, but it should be removed from the area near the inverting input to minimize any stray capacitance at that node. Carbon or Metal-Film resistors are acceptable with the Metal-Film resistors giving slightly less peaking and bandwidth because of their additional series inductance. Use of sockets, particularly for the SO package should be avoided if possible. Sockets add parasitic inductance and capacitance which will result in some additional peaking and overshoot.

Disable/Power-Down

The EL2276 amplifier can be disabled, placing its output in a high-impedance state. When disabled, the amplifier's supply current is reduced to 0mA. The EL2276 amplifier is disabled when its $\overline{\text{ENABLE}}$ pin is floating or pulled up to within 0.5V of the positive supply. Similarly, the amplifier is enabled by pulling its $\overline{\text{ENABLE}}$ pin at least 3V below the positive supply. For $\pm 5V$ supplies, this means that an EL2276 amplifier will be enabled when $\overline{\text{ENABLE}}$ is at 2V or less, and disabled when $\overline{\text{ENABLE}}$ is above 4.5V. Although the logic levels are not standard TTL, this choice of logic voltages allows the EL2276 to be enabled by tying $\overline{\text{ENABLE}}$ to ground, even in +3V single-supply applications. The $\overline{\text{ENABLE}}$ pin can be driven from CMOS outputs or open-collector TTL.

When enabled, supply current does vary somewhat with the voltage applied at $\overline{\text{ENABLE}}$. For example, with the supply voltages of the EL2276 at $\pm 5V$, if $\overline{\text{ENABLE}}$ is tied to -5V (rather than ground) the supply current will increase about 15% to 2.3mA.

Capacitance at the Inverting Input

Any manufacturer's high-speed voltage- or current-feedback amplifier can be affected by stray capacitance at the inverting input. For inverting gains this parasitic capacitance has little effect because the inverting input is a virtual ground, but for non-inverting gains this capacitance (in conjunction with the feedback and gain resistors) creates a pole in the feedback path of the amplifier. This pole, if low enough in frequency, has the same destabilizing effect as a zero in the forward open-loop response. The use of large value feedback and gain resistors further exacerbates the problem by further lowering the pole frequency.

The EL2276 has been specially designed to reduce power dissipation in the feedback network by using large 1.0k Ω feedback and gain resistors. With the high bandwidths of this amplifier, these large resistor values would normally cause stability problems when combined with parasitic capacitance, but by internally canceling the effects of a nominal amount of parasitic capacitance, the EL2276 remains very stable. For less experienced users, this feature makes the EL2276 much more forgiving, and therefore easier to use than other products not incorporating this proprietary circuitry.

The experienced user with a large amount of PC board layout experience may find in rare cases that the EL2276 has less bandwidth than expected. In this case, the inverting input may have less parasitic capacitance than expected by the internal compensation circuitry of the EL2276. The reduction of feedback resistor values (or the addition of a very small amount of external capacitance at the inverting input, e.g., 0.5pF) will increase bandwidth as desired. Please see the curves for Frequency Response for Various R_F and R_G , and Frequency Response for Various C_{IN} .

Feedback Resistor Values

The EL2276 has been designed and specified at gains of +1 and +2 with $R_F = 1.0k\Omega$. This value of feedback resistor gives 70MHz of -3dB bandwidth at $A_V = +1$ with about 1.5dB of peaking, and 60MHz of -3dB bandwidth at $A_V = +2$ with about 0.5dB of peaking. Since the EL2276 is current-feedback amplifier, it is also possible to change the value of R_F to get more bandwidth. As seen in the curve of Frequency Response For Various R_F and R_G , bandwidth and peaking can be easily modified by varying the value of the feedback resistor.

Because the EL2276 is a current-feedback amplifier, the gain-bandwidth product is not a constant for different closed-loop gains. This feature actually allows the EL2276 to maintain about the same -3dB bandwidth, regardless of closed-loop gain. However, as closed-loop gain is increased, bandwidth decreases slightly while stability increases.

Since the loop stability is improving with higher closed-loop gains, it becomes possible to reduce the value of R_F below the specified $1.0k\Omega$ and still retain stability, resulting in only a slight loss of bandwidth with increased closed-loop gain.

Supply Voltage Range and Single-Supply Operation

The EL2276 has been designed to operate with supply voltages having a span of greater than 3V, and less than 12V. In practical terms, this means that the EL2276 will operate on dual supplies ranging from $\pm 1.5V$ to $\pm 6V$.

As supply voltages continue to decrease, it becomes necessary to provide input and output voltage ranges that can get as close as possible to the supply voltages. The EL2276 has an input voltage range that extends to within 1V of either supply. So, for example, on a single +5V supply, the EL2276 has an input range which spans from 1V to 4V. The output range of the EL2276 is also quite large, extending to within 1V of the supply rail. On a $\pm 5V$ supply, the output is therefore capable of swinging from -4V to +4V. Single-supply output range is even larger because of the increased negative swing due to the external pull-down resistor to ground. On a single +5V supply, output voltage range is about 0.3V to 4V.

Video Performance

For good video performance, an amplifier is required to maintain the same output impedance and the same frequency response as DC levels are changed at the output. This is especially difficult when driving a standard video load of 150Ω , because of the change in output current with DC level. Until the EL2276, good Differential Gain could only be achieved by running high idle currents through the output transistors (to reduce variations in output impedance). These currents were typically in excess of the entire 1mA supply current of the EL2276 amplifier! Special circuitry has been incorporated in the EL2276 to reduce the variation of output impedance with current output. This results in dG and

dP specifications of 0.15% and 0.15° while driving 150Ω at a gain of +2.

Video Performance has also been measured with a 500Ω load at a gain of +1. Under these conditions, the EL2276 has dG and dP specifications of 0.01% and 0.02° respectively while driving 500Ω at $A_V = +1$.

Output Drive Capability

Each amplifier of the EL2276 is capable of providing a minimum of $\pm 50mA$. These output drive levels are unprecedented in amplifiers running at these supply currents. The $\pm 50mA$ minimum output drive of each EL2276 amplifier allows swings of $\pm 2.5V$ into 50Ω loads.

Driving Cables and Capacitive Loads

When used as a cable driver, double termination is always recommended for reflection-free performance. For those applications, the back-termination series resistor will decouple the EL2276 from the cable and allow extensive capacitive drive. However, other applications may have high capacitive loads without a back-termination resistor. In these applications, a small series resistor (usually between 5Ω and 50Ω) can be placed in series with the output to eliminate most peaking. The gain resistor (R_G) can then be chosen to make up for any gain loss which may be created by this additional resistor at the output. In many cases it is also possible to simply increase the value of the feedback resistor (R_F) to reduce the peaking.

Current Limiting

The EL2276 has no internal current-limiting circuitry. If any output is shorted, it is possible to exceed the Absolute Maximum Ratings for output current or power dissipation, potentially resulting in the destruction of the device.

Power Dissipation

With the high output drive capability of the EL2276, it is possible to exceed the $150^\circ C$ Absolute Maximum junction temperature under certain very high load current conditions. Generally speaking, when R_L falls below about 25Ω , it is important to calculate the maximum junction temperature (T_{JMAX}) for the application to determine if power-supply voltages, load conditions, or package type need to be modified for the EL2276 to remain in the safe operating area. These parameters are calculated as follows:

$$T_{JMAX} = T_{MAX} + (\theta_{JA} * n * PD_{MAX})$$

where:

T_{MAX} = Maximum Ambient Temperature

θ_{JA} = Thermal Resistance of the Package

n = Number of Amplifiers in the Package

PD_{MAX} = Maximum Power Dissipation of each Amplifier in the Package

PD_{MAX} for each amplifier can be calculated as follows:

$$PD_{MAX} = (2 * V_S * I_{SMAX}) + (V_S - V_{OUTMAX}) * (V_{OUTMAX}/R_L)$$

where:

V_S =Supply Voltage

I_{SMAX} =Maximum Supply Current of 1 Amplifier

V_{OUTMAX} =Max. Output Voltage of the Application

R_L =Load Resistance

Typical Application Circuits

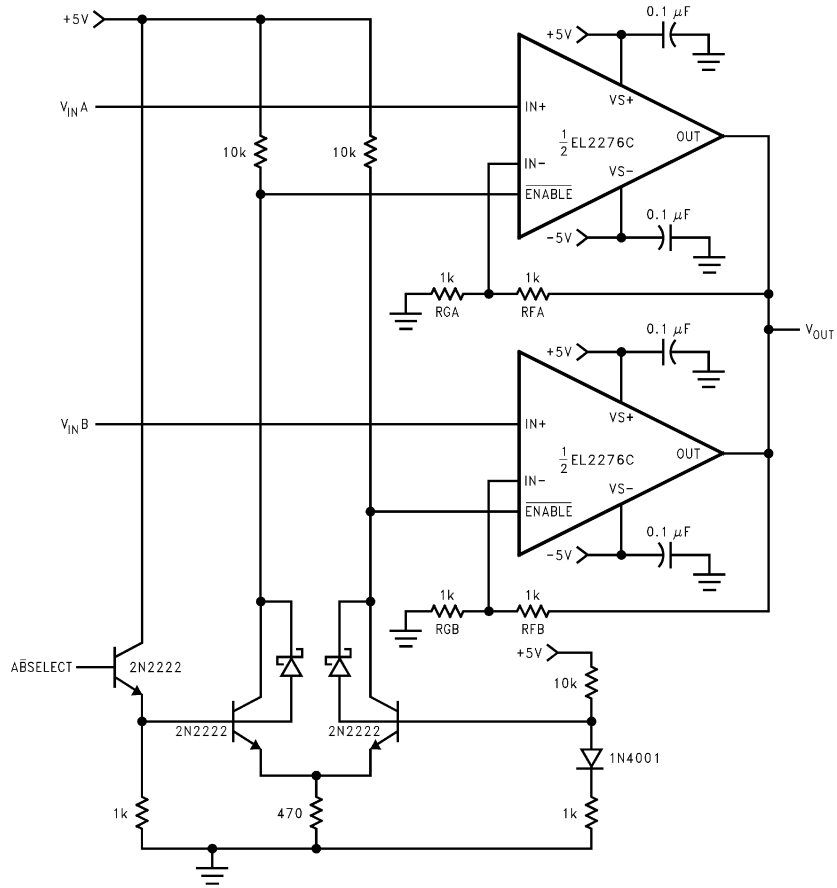

LOW POWER MULTIPLEXER WITH SINGLE-ENDED TTL INPUT

Typical Application Circuits (Continued)

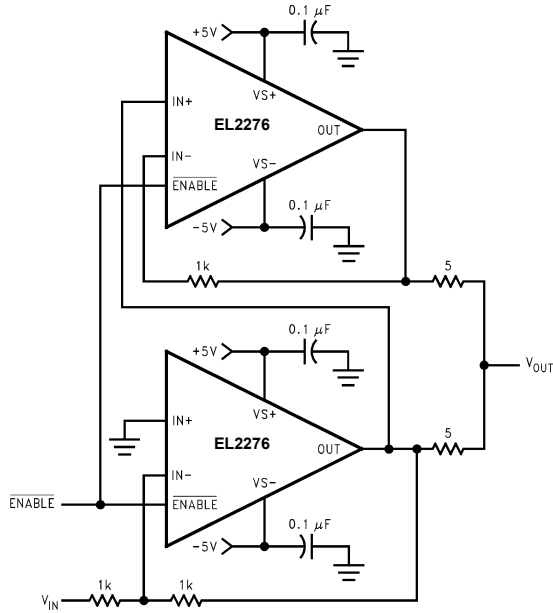

INVERTING 200mA OUTPUT CURRENT DISTRIBUTION AMPLIFIER

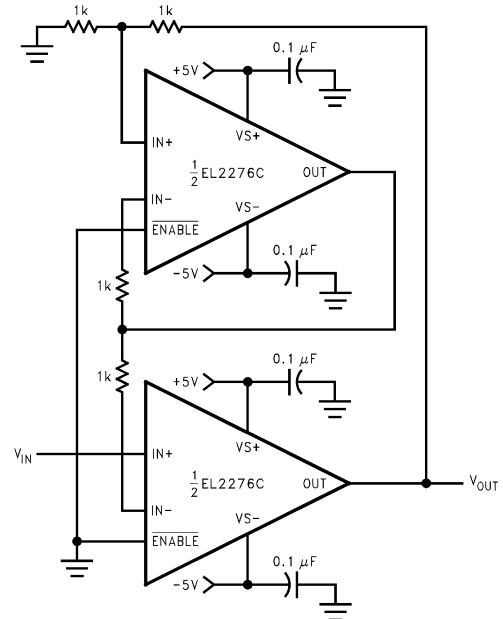

FAST-SETTLING PRECISION AMPLIFIER

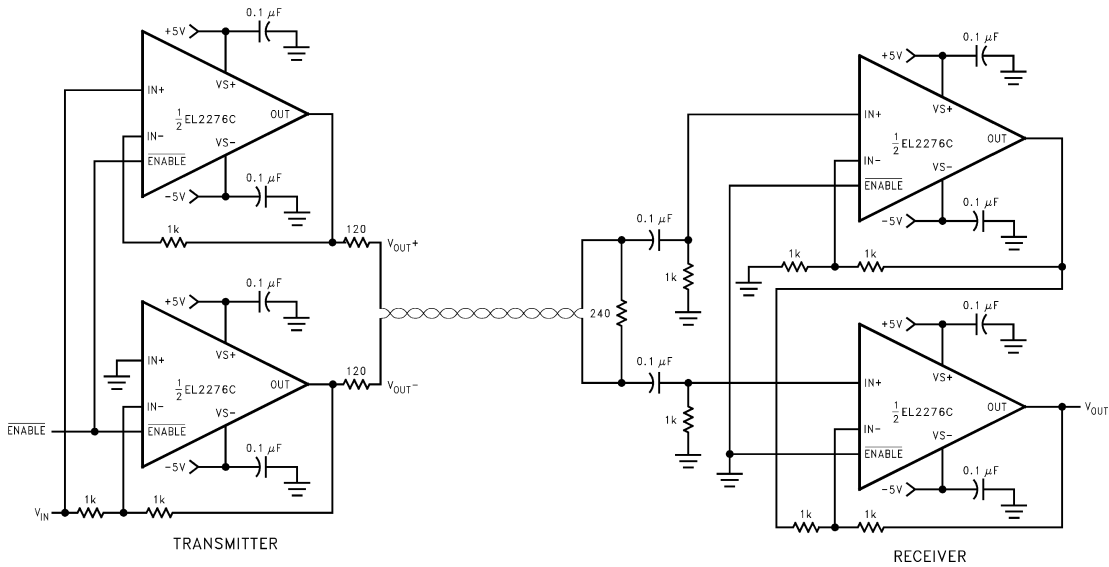

DIFFERENTIAL LINE-DRIVER/RECEIVER

EL2276 Macromodel

* Revision A, March 1995

* AC characteristics used $R_f = R_g = 1k\Omega$, $R_L = 150\Omega$

```
* Connections:      +input
*                   |
*                   | -input
*                   |
*                   | +Vsupply
*                   |
*                   | -Vsupply
*                   |
*                   | output
*                   |
.subckt EL2276/el 1 14 11 4 13
*
```

* Input Stage

```
*
e1 10 0 1 0 1.0
vis 10 9 0V
h2 9 12 vxx 1.0
r1 14 110 165
l1 110 12 25nH
iinp 1 0 0.5uA
iinm 14 0 4uA
r12 1 0 4Meg
*
```

* Slew Rate Limiting

```
*
h1 130 0 vis 600
r2 130 140 1K
d1 140 0 dclamp
d2 0 140 dclamp
*
```

* High Frequency Pole

```
*
e2 30 0 140 0 0.001666666666
l3 30 17 0.5uH
c5 17 0 0.69pF
r5 17 0 300
*
```

* Transimpedance Stage

```
*
g1 0 18 17 0 1.0
ro1 18 0 400K
cdp 18 0 1.9pF
*
```

* Output Stage

```
*
q1 4 18 19 qp
q2 11 18 20 qn
q3 11 19 21 qn
q4 4 20 22 qp
r7 21 13 4
r8 22 13 4
ios1 11 19 0.4mA
ios2 20 4 0.4mA
*
```

* Supply Current

```
*
ips 11 4 1nA
*
```

* Error Terms

*

```

ivos 0 23 2mA
vxx 23 0 0V
e4 24 0 1 0 1.0
e5 25 0 11 0 1.0
e6 26 0 4 0 -1.0
r9 24 23 0.316K
r10 25 23 3.2K
r11 26 23 3.2K
*
* Models
*
.model qn npn(is=5e-15 bf=200 tf=0.01nS)
.model qp pnp(is=5e-15 bf=200 tf=0.01nS)
.model dclamp d(is=1e-30 ibv=0.266
+ bv=1.3v n=4)
.ends
    
```

EL2276 Macromodel (Continued)

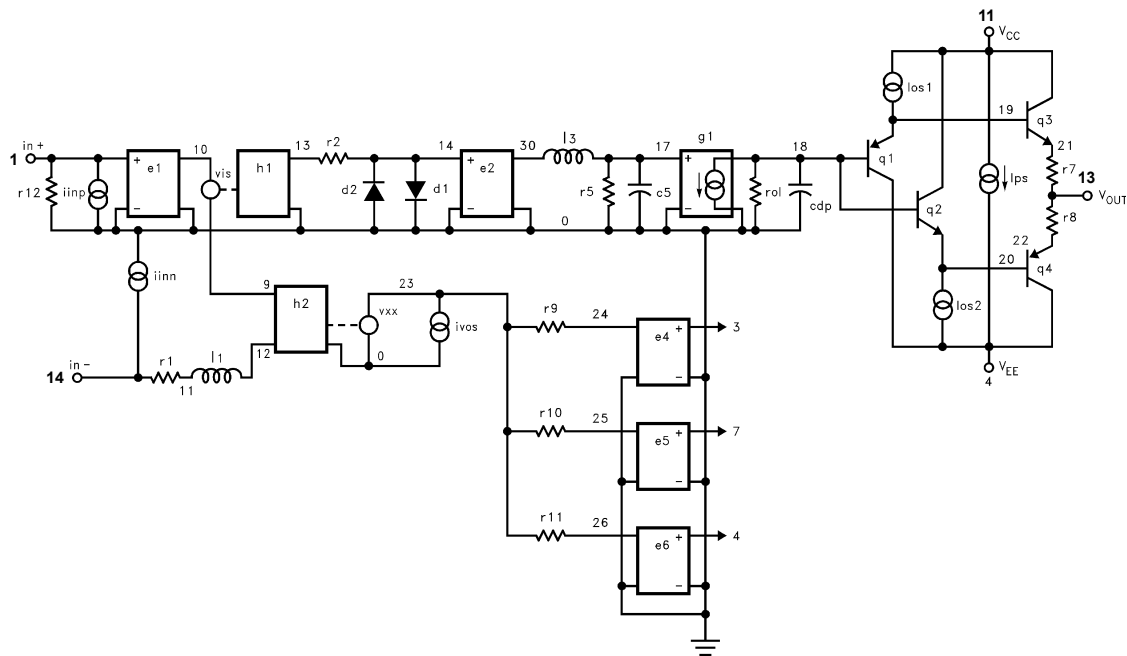

© Copyright Intersil Americas LLC 1995-2005. All Rights Reserved.
 All trademarks and registered trademarks are the property of their respective owners.

For additional products, see www.intersil.com/en/products.html

Intersil products are manufactured, assembled and tested utilizing ISO9001 quality systems as noted in the quality certifications found at www.intersil.com/en/support/qualandreliability.html

Intersil products are sold by description only. Intersil may modify the circuit design and/or specifications of products at any time without notice, provided that such modification does not, in Intersil's sole judgment, affect the form, fit or function of the product. Accordingly, the reader is cautioned to verify that datasheets are current before placing orders. Information furnished by Intersil is believed to be accurate and reliable. However, no responsibility is assumed by Intersil or its subsidiaries for its use; nor for any infringements of patents or other rights of third parties which may result from its use. No license is granted by implication or otherwise under any patent or patent rights of Intersil or its subsidiaries.

For information regarding Intersil Corporation and its products, see www.intersil.com