

TABLE 1			
ITEM	COMPONENT	HH	GF
1	SUB ASSEMBLY	SUB-CJT-T-P-HH-RA-BH1	SUB-CJT-T-P-GF-RA-BH1
2	NUT	SMA-NUT-001-F	
3	WASHER	SMA-LWAS-001-F	
4	GASKET	CJT-GKT-001	

DO NOT SCALE FROM THIS PRINT

DESIGNED & DIMENSIONED IN MILLIMETERS [INCHES]

CJT-T-P-XX-RA-BH1

GENDER
-J: JACK

TYPE
-T: TERMINAL

TYPE
-P: PCB

TERMINATION
-BH1: BULKHEAD THROUGH HOLE

ORIENTATION
-RA: RIGHT ANGLE

PLATING SPECIFICATION
 -HH: HEAVY GOLD / HEAVY GOLD
 30µ" Au / 50µ" Ni MIN ON PIN
 30µ" Au / 50µ" Ni MIN ON OUTER CONTACT
 -GF: GOLD / FLASH GOLD
 10µ" Au / 50µ" Ni MIN ON PIN
 3µ" Au / 50µ" Ni MIN ON OUTER CONTACT
 (SEE TABLE 1)

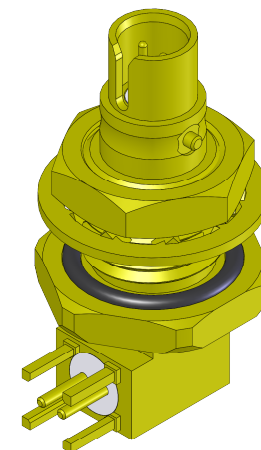
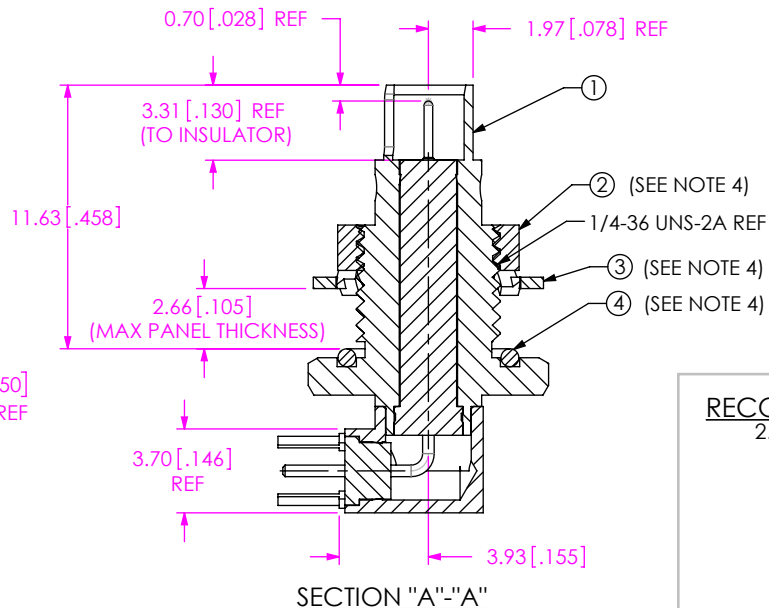
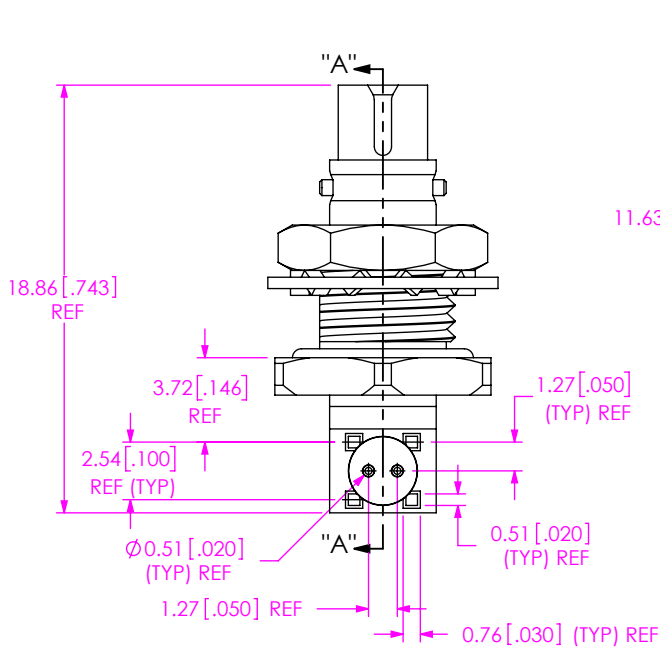
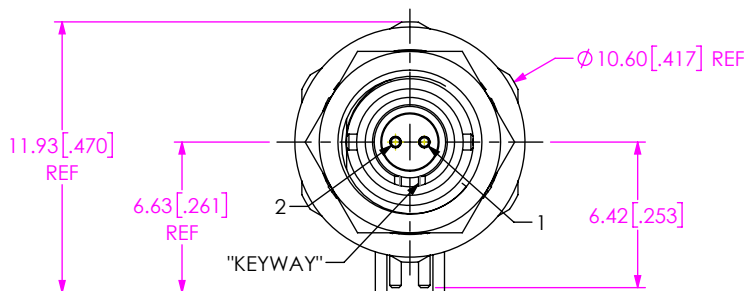

RECOMMENDED MOUNTING HOLE
2.66 [.105] MAX PANEL THICKNESS

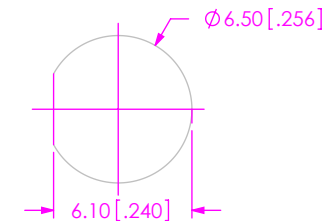

NOTES:

1. Ⓢ REPRESENTS A CRITICAL DIMENSION.
2. MINIMUM PUSHOUT FORCE FOR CENTER CONTACT: 10 N [2.25 LB].
INSULATOR: 20 N [4.5 LB].
3. PRODUCT TO BE PACKAGED PER PACKAGING STANDARD CO-HD-WI-3040-M.
TRAY: TY-SMA001-1,
COVER: TY-SMA001-2.
4. NUT, WASHER, AND GASKET ARE PACKAGED SEPARATELY.

UNLESS OTHERWISE SPECIFIED, DIMENSIONS ARE IN MILLIMETERS.

TOLERANCES ARE:
 DECIMALS ANGLES
 X.X: ±0.3 [.01] 5°
 X.XX: ±0.13 [.005]
 X.XXX: ±0.051 [.0020]

PROPRIETARY NOTE

THIS DOCUMENT CONTAINS CONFIDENTIAL AND PROPRIETARY INFORMATION AND ALL DESIGN, MANUFACTURING, REPRODUCTION, USE, PATENT RIGHTS AND SALES RIGHTS ARE EXPRESSLY RESERVED BY SAMTEC, INC. THIS DOCUMENT SHALL NOT BE DISCLOSED, IN WHOLE OR PART, TO ANY UNAUTHORIZED PERSON OR ENTITY NOR REPRODUCED, TRANSFERRED OR INCORPORATED IN ANY OTHER PROJECT IN ANY MANNER WITHOUT THE EXPRESS WRITTEN CONSENT OF SAMTEC, INC.

MATERIAL: DO NOT SCALE DRAWING SHEET SCALE: 3:1
 CONTACT: PHOS BRONZE
 OTHER METAL: BRASS
 DIELECTRIC: PTFE
 GASKET: SILICONE

samtec

520 PARK EAST BLVD. NEW ALBANY, IN 47150
 PHONE: 812-944-6733 FAX: 812-948-5047
 e-Mail info@SAMTEC.com code 55322

DESCRIPTION:
CIRCULAR TWIN-AX JACK RIGHT ANGLE BULKHEAD

DWG. NO. CJT-T-P-XX-RA-BH1

BY: ALVIN W 12/01/2010 SHEET 1 OF 2

RECOMMENDED PCB LAYOUT

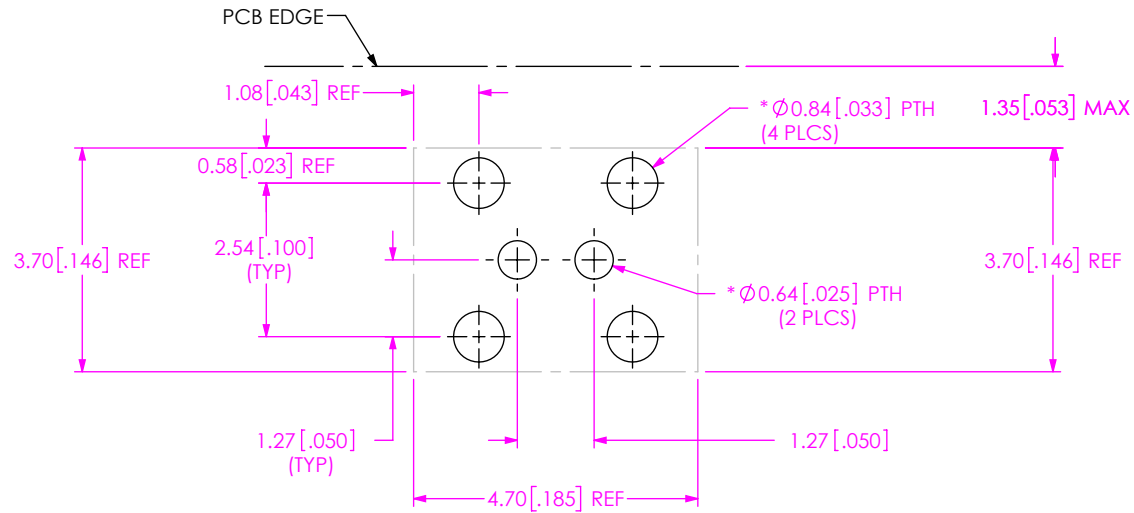

* TO BE SOLDERED USING PASTE-IN-HOLE TECHNOLOGY.

RECOMMENDED STENCIL LAYOUT

NOTE:
STENCIL TO BE .152 [.0060] THICK

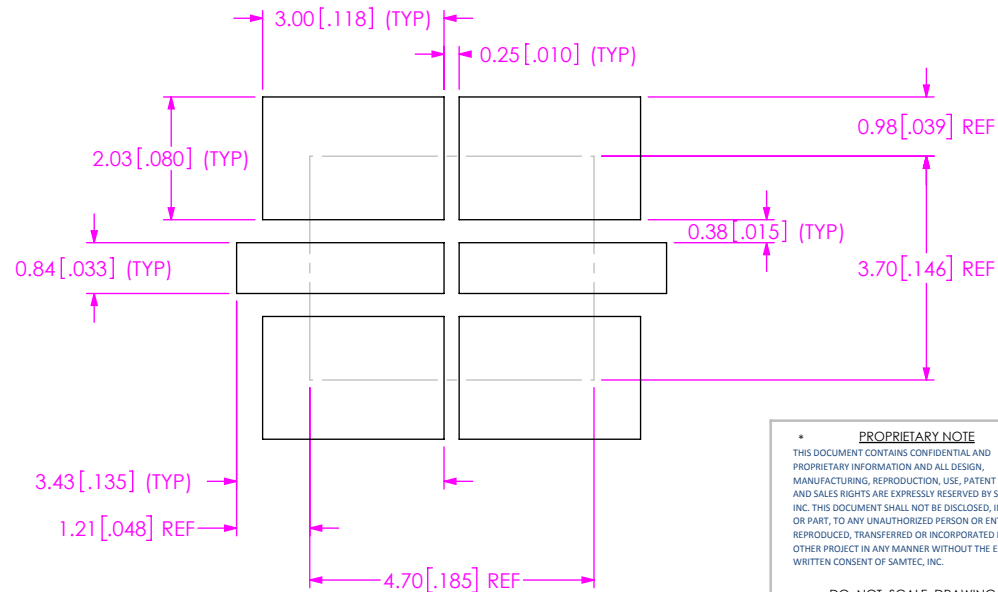

PROPRIETARY NOTE
THIS DOCUMENT CONTAINS CONFIDENTIAL AND PROPRIETARY INFORMATION AND ALL DESIGN, MANUFACTURING, REPRODUCTION, USE, PATENT RIGHTS AND SALES RIGHTS ARE EXPRESSLY RESERVED BY SAMTEC, INC. THIS DOCUMENT SHALL NOT BE DISCLOSED, IN WHOLE OR PART, TO ANY UNAUTHORIZED PERSON OR ENTITY NOR REPRODUCED, TRANSFERRED OR INCORPORATED IN ANY OTHER PROJECT IN ANY MANNER WITHOUT THE EXPRESS WRITTEN CONSENT OF SAMTEC, INC.

DO NOT SCALE DRAWING
SHEET SCALE: 8:1



520 PARK EAST BLVD. NEW ALBANY, IN 47150
PHONE: 812-944-6733 FAX: 812-948-5047
e-Mail info@SAMTEC.com code 55322

DESCRIPTION:
CIRCULAR TWIN-AX JACK RIGHT ANGLE BULKHEAD

DWG. NO. CJT-T-P-XX-RA-BH1

BY: ALVIN W 12/01/2010 SHEET 2 OF 2