

Device Features

- Fully Qualified Bluetooth v2.0+EDR
- Enhanced Data Rate (EDR) compliant with v2.0 of the specification for both 2Mbps and 3Mbps modulation modes
- Full Speed Bluetooth Operation with Piconet and Scatternet Support
- Embedded 6Mbit Flash
- Low Power 1.8V operation
- Integrated Switch-mode Regulator
- Integrated Battery Charger with Programmable Current
- 8 x 8mm 96-ball TFBGA Package
- UART Port
- 15-bit Linear Audio CODEC
- 4.2V Tolerant LED Drivers with Intensity Control

General Description

BlueCore™4-Audio Flash is a single chip radio and baseband IC for Bluetooth 2.4GHz systems including enhanced data rates (EDR) to 3Mbps.

BlueCore4-Audio Flash contains 6Mbits of internal Flash memory. When used with the CSR Bluetooth software stack, it provides a fully compliant Bluetooth system to v2.0 + EDR of the specification for data and voice communications.

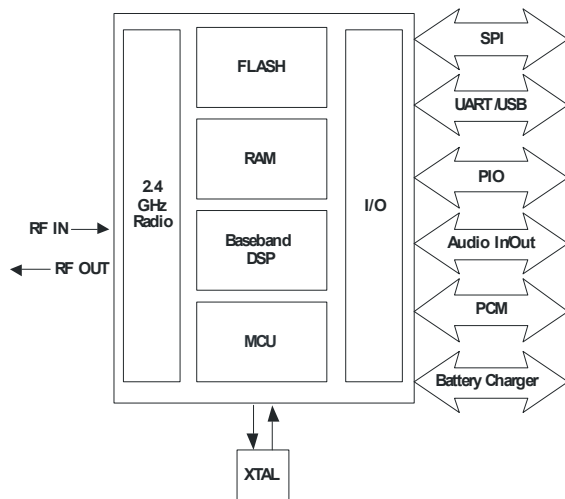

System Architecture

BlueCore™4-Audio Flash

Single Chip Bluetooth® v2.0 + EDR System

Production Information Data Sheet For
BC41C671A
January 2007

Applications

- Headsets
- Automotive Hands-Free Kits
- General purpose Bluetooth systems requiring an on-chip audio CODEC

BlueCore4-Audio Flash has been designed to reduce the number of external components required which ensures production costs are minimised. The device incorporates auto-calibration and built in self test (BIST) routines to simplify development, type approval and production test. All hardware and device firmware is fully compliant with the Bluetooth v2.0 + EDR specification (all mandatory and optional features).

Contents

1	Key Features	9
2	Package Information	10
2.1	BC41C671A Pinout Diagram	10
2.2	Device Terminal Functions	11
3	Electrical Characteristics	16
3.1	Absolute Maximum Ratings	16
3.2	Recommended Operating Conditions	16
3.3	Linear Regulator	17
3.4	Switch-mode Regulator	18
3.5	Battery Charger	19
3.6	Digital Terminals	20
3.7	USB Terminals	20
3.8	Power on Reset	21
3.9	Auxilliary ADC	21
3.10	Auxilliary DAC	22
3.11	Clocks	22
3.12	Audio CODEC	23
3.13	Power Consumption	24
3.13.1	Typical Average Current	24
3.13.2	Typical Measurement Conditions	24
4	Radio Characteristics - Basic Data Rate	25
4.1	Temperature +20°C	25
4.1.1	Transmitter	25
4.1.2	Receiver	26
4.2	Temperature -40°C	27
4.2.1	Transmitter	27
4.2.2	Receiver	27
4.3	Temperature -25°C	28
4.3.1	Transmitter	28
4.3.2	Receiver	28
4.4	Temperature +85°C	29
4.4.1	Transmitter	29
4.4.2	Receiver	29
4.5	Temperature +105°C	30
4.5.1	Transmitter	30
4.5.2	Receiver	30
5	Radio Characteristics - Enhanced Data Rate	31
5.1	Temperature +20°C	31
5.1.1	Transmitter	31
5.1.2	Receiver	32
5.2	Temperature -40°C	33
5.2.1	Transmitter	33
5.2.2	Receiver	34
5.3	Temperature -25°C	35
5.3.1	Transmitter	35
5.3.2	Receiver	36
5.4	Temperature +85°C	37
5.4.1	Transmitter	37
5.4.2	Receiver	38

6	Device Diagram	39
7	Description of Functional Blocks	40
7.1	RF Receiver	40
7.1.1	Low Noise Amplifier	40
7.1.2	Analogue to Digital Converter	40
7.2	RF Transmitter	40
7.2.1	IQ Modulator	40
7.2.2	Power Amplifier	40
7.3	RF Synthesiser	40
7.4	Switch-Mode Regulator	40
7.5	Linear Regulator	40
7.6	Battery Charger	40
7.7	Clock Input and Generation	40
7.8	Baseband and Logic	41
7.8.1	Memory Management Unit	41
7.8.2	Burst Mode Controller	41
7.8.3	Physical Layer Hardware Engine DSP	41
7.8.4	System RAM	41
7.8.5	Flash Memory (6Mbit)	41
7.8.6	USB	41
7.8.7	Synchronous Serial Interface	41
7.8.8	UART	41
7.9	Microcontroller	42
7.9.1	Programmable I/O	42
7.9.2	PCM Interface	42
7.9.3	Audio CODEC	42
7.9.4	LED Driver	42
8	Device Terminal Descriptions	43
8.1	RF Ports	43
8.1.1	RF_P and RF_N	43
8.1.2	Single-Ended Input	44
8.1.3	Transmit RF Power Control for Class 1 Applications (TX_PWR)	44
8.1.4	Control of External RF Components	44
8.2	External Reference Clock Input (XTAL_IN)	46
8.2.1	External Mode	46
8.2.2	XTAL_IN Impedance in External Mode	46
8.2.3	Clock Timing Accuracy	46
8.2.4	Clock Start-Up Delay	47
8.2.5	Input Frequencies and PS Key Settings	48
8.3	Crystal Oscillator (XTAL_IN, XTAL_OUT)	49
8.3.1	XTAL Mode	49
8.3.2	Load Capacitance	50
8.3.3	Frequency Trim	51
8.3.4	Transconductance Driver Model	52
8.3.5	Negative Resistance Model	52
8.3.6	Crystal PS Key Settings	53
8.3.7	Crystal Oscillator Characteristics	53
8.4	UART Interface	56
8.4.1	UART Bypass	58
8.4.2	UART Configuration While RESET is Active	58
8.4.3	UART Bypass Mode	58
8.4.4	Current Consumption in UART Bypass Mode	58

8.5	USB Interface	59
8.5.1	USB Data Connections	59
8.5.2	USB Pull-Up Resistor	59
8.5.3	USB Power Supply	59
8.5.4	Self-Powered Mode	60
8.5.5	Bus-Powered Mode	60
8.5.6	Suspend Current	61
8.5.7	Detach and Wake_Up Signalling	61
8.5.8	USB Driver	62
8.5.9	USB 1.1 Compliance	62
8.5.10	USB 2.0 Compatibility	62
8.6	Serial Peripheral Interface	63
8.6.1	Instruction Cycle	63
8.6.2	Writing to the Device	64
8.6.3	Reading from the Device	64
8.6.4	Multi-Slave Operation	64
8.7	Mono Audio CODEC	65
8.7.1	Input Stage	65
8.7.2	Microphone Input	66
8.7.3	Line Input	66
8.7.4	Output Stage	67
8.7.5	Single-Ended Speaker Termination	69
8.7.6	Bass Cut (Wind Noise Reduction)	69
8.7.7	Side Tone	69
8.7.8	Audio CODEC Outline and Applicable Gains	70
8.7.9	Firmware Interface	71
8.8	PCM CODEC Interface	76
8.8.1	PCM Interface Master/Slave	76
8.8.2	Long Frame Sync	77
8.8.3	Short Frame Sync	78
8.8.4	Multi-slot Operation	78
8.8.5	GCI Interface	79
8.8.6	Slots and Sample Formats	79
8.8.7	Additional Features	80
8.8.8	PCM Timing Information	81
8.8.9	PCM Configuration	84
8.9	I/O Parallel Ports	86
8.9.1	PIO Defaults	86
8.10	I2C Interface	87
8.11	TCXO Enable OR Function	87
8.12	RESETB	89
8.12.1	Pin States on Reset	90
8.12.2	Status after Reset	90
8.13	Power Supply	91
8.13.1	Power Regulators	91
8.13.2	Supply Domains and Sequencing	91
8.13.3	External Voltage Source	91
8.13.4	Switch-mode Regulator	91
8.13.5	Linear Regulator	91
8.13.6	VREG_ENABLE Pin	91
8.13.7	Battery Charger	91
8.13.8	LED Drivers	92

9	Application Schematic	93
10	Package Dimensions	94
11	PCB Design and Assembly Considerations	95
11.1	8 x 8mm TFBGA 96-Ball Package	95
12	RoHS Statement with a List of Banned Materials	96
12.1	RoHS Statement	96
12.1.1	List of Banned Materials	96
13	Ordering Information	97
13.1	BlueCore4-Audio Flash	97
14	Document References	98
15	Terms and Definitions	99
16	Document History	102

List of Figures

Figure 2.1	BlueCore4-Audio Flash Device Pinout.....	10
Figure 6.1	BlueCore4-Audio Flash Device Diagram	39
Figure 8.1	Circuit RF_P and RF_N	43
Figure 8.2	TCXO Clock Accuracy	46
Figure 8.3	Crystal Driver Circuit	49
Figure 8.4	Crystal Equivalent Circuit.....	49
Figure 8.5	Crystal Load Capacitance and Series Resistance Limits with Crystal Frequency.....	53
Figure 8.6	Crystal Driver Transconductance vs. Driver Level Register Setting	54
Figure 8.7	Crystal Driver Negative Resistance as a Function of Drive Level Setting	55
Figure 8.8	Universal Asynchronous Receiver	56
Figure 8.9	Break Signal.....	57
Figure 8.10	UART Bypass Architecture	58
Figure 8.11	USB Connections for Self-Powered Mode.....	60
Figure 8.12	USB Connections for Bus-Powered Mode.....	61
Figure 8.13	USB_DETACH and USB_WAKE_UP Signal.....	62
Figure 8.14	SPI Write Operation.....	64
Figure 8.15	SPI Read Operation.....	64
Figure 8.16	BlueCore4-Audio Flash CODEC Diagram	65
Figure 8.17	BlueCore4-Audio Flash Microphone Biasing	66
Figure 8.18	Differential Microphone Input.....	66
Figure 8.19	Single-ended Microphone Input.....	67
Figure 8.20	Speaker Output.....	67
Figure 8.21	Frequency Response of the ADC and DAC Pair	68
Figure 8.22	Simulated Wind Noise Reduction Filter Response	69
Figure 8.23	Audio CODEC Outline and Applicable Gains	70
Figure 8.24	Spectrum of Analogue and Digital ADC Output with a Full Scale Sine Wave Input	73
Figure 8.25	Spectrum of DAC Output with 1kHz Full Scale Tone.....	74
Figure 8.26	Spectrum of DAC Output with 1kHz Tone at -42dB Relative to Full Scale	75
Figure 8.27	Response of CVSD Interpolation/Decimation Filter	76
Figure 8.28	BlueCore4-Audio Flash as PCM Interface Master.....	77
Figure 8.29	BlueCore4-Audio Flash as PCM Interface Slave	77
Figure 8.30	Long Frame Sync (Shown with 8-bit Companded Sample).....	78
Figure 8.31	Short Frame Sync (Shown with 16-bit Sample).....	78
Figure 8.32	Multi-slot Operation with Two Slots and 8-bit Companded Samples.....	79
Figure 8.33	GCI Interface.....	79
Figure 8.34	16-Bit Slot Length and Sample Formats.....	80
Figure 8.35	PCM Master Timing Long Frame Sync.....	82
Figure 8.36	PCM Master Timing Short Frame Sync	82
Figure 8.37	PCM Slave Timing Long Frame Sync.....	83
Figure 8.38	PCM Slave Timing Short Frame Sync	84
Figure 8.39	Example EEPROM Connection	87
Figure 8.40	Example TCXO Enable OR Function.....	88
Figure 9.1	Application Circuit for Radio Characteristics Specification	93
Figure 10.1	8 x 8 x 1.2mm TFBGA 96-Ball Package	94

List of Tables

Table 8.1	TXRX_PIO_CONTROL Values.....	45
Table 8.2	External Clock Specifications.....	46
Table 8.3	PS Key Values for CDMA/3G Phone TCXO Frequencies	48
Table 8.4	Crystal Specification	50

Table 8.5	Possible UART Settings.....	56
Table 8.6	Standard Data Rates	57
Table 8.7	USB Interface Component Values	60
Table 8.8	Instruction Cycle for an SPI Transaction.....	63
Table 8.9	IO_KCODEC_CONFIG Control Register.....	71
Table 8.10	Recommended Settings for Audio CODEC	72
Table 8.11	PCM Master Timing	81
Table 8.12	PCM Slave Timing	83
Table 8.13	PSKEY_PCM_CONFIG32 Description.....	86
Table 8.14	PSKEY_PCM_LOW_JITTER_CONFIG Description.....	86
Table 8.15	Pin States of BlueCore4-Audio Flash on Reset.....	90

List of Equations

Equation 8.1	Output Voltage with Load Current $\leq 10\text{mA}$	44
Equation 8.2	Output Voltage with No Load Current.....	44
Equation 8.3	Internal Power Ramping	44
Equation 8.4	Load Capacitance	50
Equation 8.5	Trim Capacitance.....	51
Equation 8.6	Frequency Trim.....	51
Equation 8.7	Pullability.....	51
Equation 8.8	Transconductance Required for Oscillation.....	52
Equation 8.9	Equivalent Negative Resistance	52
Equation 8.10	Data Rate.....	57
Equation 8.11	PCM_CLK Frequency When Being Generated Using the Internal 48MHz Clock.....	84
Equation 8.12	PCM_SYNC Frequency Relative to PCM_CLK.....	84

Status Information

The status of this Data Sheet is **Production Information**.

CSR Product Data Sheets progress according to the following format:

Advance Information

Information for designers concerning CSR product in development. All values specified are the target values of the design. Minimum and maximum values specified are only given as guidance to the final specification limits and must not be considered as the final values.

All detailed specifications including pinouts and electrical specifications may be changed by CSR without notice.

Pre-Production Information

Pinout and mechanical dimension specifications finalised. All values specified are the target values of the design. Minimum and maximum values specified are only given as guidance to the final specification limits and must not be considered as the final values.

All electrical specifications may be changed by CSR without notice.

Production Information

Final Data Sheet including the guaranteed minimum and maximum limits for the electrical specifications.

Production Data Sheets supersede all previous document versions.

Life Support Policy and Use in Safety-Critical Applications

CSR's products are not authorised for use in life-support or safety-critical applications. Use in such applications is done at the sole discretion of the customer. CSR will not warrant the use of its devices in such applications.

RoHS Compliance

BlueCore4-Audio Flash devices meet the requirements of Directive 2002/95/EC of the European Parliament and of the Council on the Restriction of Hazardous Substance (RoHS).

Trademarks, Patents and Licenses

Unless otherwise stated, words and logos marked with [™] or [®] are trademarks registered or owned by CSR plc or its affiliates. Bluetooth[®] and the Bluetooth logos are trademarks owned by Bluetooth SIG, Inc. and licensed to CSR. Other products, services and names used in this document may have been trademarked by their respective owners.

The publication of this information does not imply that any license is granted under any patent or other rights owned by CSR plc.

CSR reserves the right to make technical changes to its products as part of its development programme.

While every care has been taken to ensure the accuracy of the contents of this document, CSR cannot accept responsibility for any errors.

1 Key Features

Radio

- Common TX/RX terminal simplifies external matching; eliminates external antenna switch
- BIST minimises production test time. No external trimming is required in production
- Bluetooth v2.0 + EDR Specification compliant

Transmitter

- +6dBm RF transmit power with level control from on-chip 6-bit DAC over a dynamic range >30dB
- Class 2 and Class 3 support without the need for an external power amplifier or TX/RX switch
- Class 1 support using external power amplifier with RF power controlled by an internal 8-bit DAC

Receiver

- Integrated channel filters
- Digital demodulator for improved sensitivity and co-channel rejection
- Real time digitised RSSI available on HCI interface
- Fast AGC for enhanced dynamic range

Synthesiser

- Fully integrated synthesiser; requires no external VCO, varactor diode, resonator or loop filter
- Compatible with an external crystal or with an external clock using sinusoidal or logic-level signals
- Accepts 7.68, 14.44, 15.36, 16.2, 16.8, 19.2, 19.44, 19.68, 19.8 and 38.4MHz TCXO frequencies typically used in GSM and CDMA devices with sinusoidal or logic level signals

Auxiliary Features

- Crystal oscillator with built-in digital trimming
- Power management includes digital shutdown, and wake up commands with an integrated low power oscillator for ultra low Park/Sniff/Hold mode
- Clock request output to control external clock
- On-chip high efficiency switch-mode regulator output from 2.5V to 4.2V input.
- On-chip linear regulator; 1.8V output from a 2.2 to 4.2V input, can also be used to generate microphone bias
- Power-on-reset cell detects low supply voltage

Auxiliary Features (Continued)

- Arbitrary power supply sequencing permitted
- 8-bit ADC and DAC available to applications
- Battery charger with programmable current (25 -100mA) for Lithium Ion/Polymer battery
- LED intensity control for dedicated LED1 and LED0 outputs

Baseband and Software

- Internal 6Mbit Flash for complete system solution
- Internal 48KB RAM to support EDR. Allows full speed data transfer, mixed voice and data, and full piconet operation
- Logic for forward error correction, header error control, access code correlation, CRC, demodulation, encryption bit stream generation, whitening and transmit pulse shaping
- Transcoders for A-law, μ -law and linear voice from host and A-law, μ -law and CVSD voice over air

Physical Interfaces

- Synchronous serial interface up to 4Mbits/s for system debugging
- UART interface with programmable baud rate up to 3Mbits/s with an optional bypass mode
- Full speed USB v1.1 interface supports OHCI and UHCI host interfaces. Compliant with USB v2.0
- Optional I²C™ compatible interface

Audio CODEC

- 15-bit resolution, 8kHz sampling frequency
- Digital enhancements to add bass cut, side tone and treble boost
- Analogue enhancements to support single-ended speaker drive capability and reference availability

Bluetooth Stack

CSR's Bluetooth Protocol Stack runs on-chip in a variety of configurations:

- Standard HCI (UART or USB)
- Fully embedded to RFCOMM
- Customised builds with embedded application code

Package Options

- 96-ball TFBGA, 8 x 8 x 1.2mm, 0.65mm pitch

2 Package Information

2.1 BC41C671A Pinout Diagram

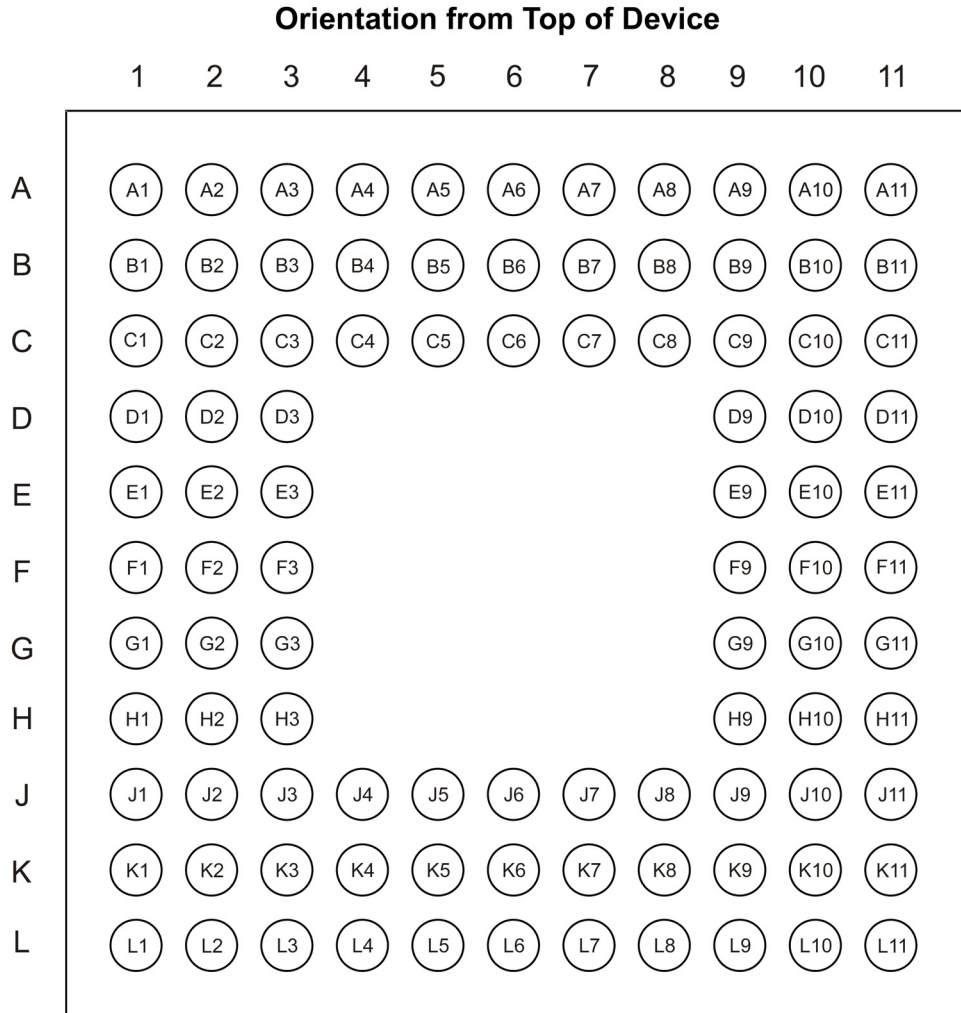

Figure 2.1: BlueCore4-Audio Flash Device Pinout

2.2 Device Terminal Functions

Radio	Ball	Pad Type	Supply Pad	Description
RX_IN	D1	Analogue	VDD_RADIO	Single ended receiver input
PIO[0]/RXEN	A1	Bi-directional with programmable strength internal pull-up/down	VDD_PIO	Control output for external TX/RX switch (if fitted)
PIO[1]/TXEN	B2	Bi-directional with programmable strength internal pull-up/down	VDD_PIO	Control output for external PA (If fitted)
RF_P	F1	Analogue	VDD_RADIO	Transmitter output/switched receiver input
RF_N	E1	Analogue	VDD_RADIO	Complement of RF_P
AUX_DAC	C3	Analogue	VDD_PIO	Voltage DAC output

Synthesiser and Oscillator	Ball	Pad Type	Supply Pad	Description
XTAL_IN	L4	Analogue	VDD_ANA	For crystal or external clock input
XTAL_OUT	K4	Analogue	VDD_ANA	Drive for crystal

USB and UART	Ball	Pad Type	Supply Pad	Description
UART_TX	K9	CMOS output, tri-state, with weak internal pull-up	VDD_USB	UART data output
UART_RX	K10	CMOS input with weak internal pull-down	VDD_USB	UART data input
UART_RTS	L8	CMOS output, tri-state, with weak internal pull-up	VDD_USB	UART request to send active low
UART_CTS	K11	CMOS input with weak internal pull-down	VDD_USB	UART clear to send active low
USB_DP	L10	Bi-directional	VDD_USB	USB data plus with selectable internal 1.5k Ω pull-up resistor
USB_DN	L9	Bi-directional	VDD_USB	USB data minus

PCM Interface	Ball	Pad Type	Supply Pad	Description
PCM_OUT	G11	CMOS output, tri-state, with weak internal pull-down	VDD_PADS	Synchronous data output
PCM_IN	J11	CMOS input, with weak internal pull-down	VDD_PADS	Synchronous data input
PCM_SYNC	H9	Bi-directional with weak internal pull-down	VDD_PADS	Synchronous data sync
PCM_CLK	H11	Bi-directional with weak internal pull-down	VDD_PADS	Synchronous data clock

PIO Port	Ball	Pad Type	Supply Pad	Description
PIO[2]/CLK_REQ	A2	Bi-directional with programmable strength internal pull-up/down	VDD_PIO	PIO or external clock request
PIO[3]/USB_WAKE_UP/ HOST_CLK_REQ	B3	Bi-directional with programmable strength internal pull-up/down	VDD_PIO	PIO or output goes high to wake up PC when in USB mode or clock request input from host controller
PIO[4]/USB_ON	F9	Bi-directional with programmable strength internal pull-up/down	VDD_PADS	PIO or USB on (input senses when VBUS is high, wakes BlueCore4-Audio Flash)
PIO[5]/USB_DETACH	F10	Bi-directional with programmable strength internal pull-up/down	VDD_PADS	PIO line or chip detaches from USB when this input is high
PIO[6]/CLK_REQ	F11	Bi-directional with programmable strength internal pull-up/down	VDD_PADS	PIO line or clock request output to enable external clock for external clock line
PIO[7]/CLK_OUT	G9	Bi-directional with programmable strength internal pull-up/down	VDD_PADS	Programmable input/output line or programmable frequency clock output
PIO[8]	A5	Bi-directional with programmable strength internal pull-up/down	VDD_PIO	Programmable input/output line
PIO[9]	A4	Bi-directional with programmable strength internal pull-up/down	VDD_PIO	Programmable input/output line
PIO[10]	B4	Bi-directional with programmable strength internal pull-up/down	VDD_PIO	Programmable input/output line
PIO[11]	A3	Bi-directional with programmable strength internal pull-up/down	VDD_PIO	Programmable input/output line
AIO[0]	J6	Bi-directional	VDD_USB	Programmable input/output line
AIO[1]	L6	Bi-directional	VDD_USB	Programmable input/output line
AIO[2]	L7	Bi-directional	VDD_USB	Programmable input/output line
LED[0]	A9	Open drain output	VDD_BAT	Current sink to drive LED
LED[1]	A10	Open drain output	VDD_BAT	Current sink to drive LED

Test and Debug	Ball	Pad Type	Supply Pad	Description
MIC_P	L2	Analogue	VDD_ANA	Microphone differential, Input P
MIC_N	L3	Analogue	VDD_ANA	Microphone differential, Input N
SPKR_P	J2	Analogue	VDD_ANA	Speaker differential output P or single ended output
SPKR_N	J1	Analogue	VDD_ANA	Speaker differential output N

Test and Debug	Ball	Pad Type	Supply Pad	Description
RESETB	D10	CMOS input with weak internal pull-up	VDD_PADS	Reset if low. Input debounced so must be low for >5ms to cause a reset
SPI_CSB	B9	CMOS input with weak internal pull-up	VDD_PADS	Chip select for Synchronous Serial Interface active low
SPI_CLK	C11	CMOS input with weak internal pull-down	VDD_PADS	Serial Peripheral Interface clock
SPI_MOSI	C9	CMOS input with weak internal pull-down	VDD_PADS	Serial Peripheral Interface data input
SPI_MISO	B11	CMOS output, tri-state, with weak internal pull-down	VDD_PADS	Serial Peripheral Interface data output
TEST_EN	C10	CMOS input with strong internal pull-down	VDD_PADS	For test purposes only(leave unconnected)

Power Supplies and Control	Ball	Pad Type	Description
VREG_ENABLE	H3	CMOS input	Regulator control input
VREG_IN	H1	Regulator input	Linear regulator input
VREG_OUT	K1	Regulator output	Linear regulator output
V_CHG	A11	Charger input	Lithium Ion battery charger input
BAT_P	A8	Battery terminal +	Lithium Ion battery positive terminal/Ground connection for switch-mode regulator
BAT_N	A7	Battery terminal -	Lithium Ion battery negative terminal/Ground connection for switch-mode regulator
LX	A6	Switch-mode regulator output	Switch-mode power regulator output
VDD_USB	L11	VDD	Positive supply for UART/USB ports and AIOs
VDD_PIO	B1	VDD	Positive supply for PIO and AUX DAC ^(a)
VDD_MEM	B6,B8,J7,K8	VDD	Positive supply for memory. Connect to VDD_CORE to provide pin compatibility with previous devices
VDD_PADS	D11	VDD	Positive supply for all digital Input/Output ports ^(b)
VDD_CORE	E11	VDD	Positive supply for internal digital circuitry
VDD_RADIO	C1	VDD/Regulator sense	Positive supply for RF circuitry
VDD_VCO	H2	VDD	Positive supply for local oscillator circuitry
VDD_ANA	L1,L5	VDD	Positive supply for analogue circuitry and 1.8V regulated output
VSS_MEM	C5,C7	VSS	Ground connection for memory. Connect to provide pin compatibility with future devices
VSS_PADS	C4, C8, D9,J9	VSS	Ground connection for input/output ports
VSS_CORE	E9	VSS	Ground connection for internal digital circuitry
VSS_RADIO	C2,D2,E2,F2	VSS	Ground connections for RF circuitry
VSS_VCO	G1,G2	VSS	Ground connections for local oscillator
VSS_ANA	J3,J4,J5,K2,K3	VSS	Ground connections for analogue circuitry
VSS	E3	VSS	Ground connection

^(a) Positive supply for PIO[3:0] and PIO[11:6].

^(b) Positive supply for SPI/PCM ports and PIO[7:4]

Unconnected Terminals	Ball	Description
N/C	B5, B7, B10, C6, D3, E10, F3, G3, G10, H10, J8, J10, K5, K6, K7	Leave unconnected

3 Electrical Characteristics

3.1 Absolute Maximum Ratings

Rating	Min	Max
Storage temperature	-40°C	+150°C
Supply voltage: VDD_RADIO, VDD_VCO, VDD_ANA and VDD_CORE	-0.4V	2.2V
Supply voltage: VDD_PADS, VDD_PIO, VDD_MEM and VDD_USB	-0.4V	3.7V
Supply Voltage: VREG_IN	-0.4V	5.6V
Supply Voltage: BAT_P, VREG_ENABLE and LED [1:0]	-0.4V	4.25V
Supply Voltage: V_CHG	-0.4V	6.5V
Other terminal voltages	VSS-0.4V	VDD+0.4V

3.2 Recommended Operating Conditions

Operating Condition	Min	Max
Operating temperature range	-40°C	+105°C
Guaranteed RF performance range ^(a)	-25°C	+85°C
Supply voltage: VDD_RADIO, VDD_VCO, VDD_ANA and VDD_CORE	1.7V	1.9V
Supply voltage: VDD_PADS, VDD_PIO, VDD_MEM and VDD_USB	1.7V	3.6V
Supply voltage: VREG_IN	2.2V	4.2V ^(b)
Supply voltage: BAT_P, VREG_ENABLE and LED [1:0]	2.5V	4.2V
Supply voltage: V_CHG	4.35V	6.5V

(a) Typical figures are given for RF performance between -40°C and +105°C.

(b) The device will operate without damage with VREG_IN as high as 5.6V. However the RF performance is not guaranteed above 4.2V.

3.3 Linear Regulator

Linear Regulator	Min	Typ	Max	Unit
Normal Operation				
Input voltage	2.2	-	4.2 ^(a)	V
Dropout voltage ($I_{load} = 70\text{ mA}$)	-	-	350	mV
Output Voltage ^(b) ($I_{load} = 70\text{ mA}$)	1.70	1.78	1.85	V
Temperature Coefficient	-250	-	+250	ppm/°C
Output Noise ^(c) ^(d)	-	-	1	mV rms
Load Regulation ($I_{load} < 100\text{ mA}$)	-	-	50	mV/A
Settling Time ^(c) ^(e)	-	-	50	μs
Maximum Output Current	100	-	-	mA
Minimum Load Current	5	-	-	μA
Input Voltage	-	-	4.2	V
Quiescent Current (excluding load, $I_{load} < 1\text{ mA}$)	25	35	50	μA
Low Power Mode^(f)				
Quiescent Current (excluding load, $I_{load} < 100\mu\text{A}$)	4	7	10	μA
Disabled Mode^(g)				
Quiescent Current	1.5	2.5	3.5	μA

- (a) Operation up to 5.6V is permissible without damage and without the output voltage rising sufficiently to damage the rest of BlueCore4-Audio Flash, but output regulation and other specifications are no longer guaranteed at input voltages in excess of 4.2V.
- (b) If the Linear Regulator is used as the power supply, the VDD_ANA ball adjacent to VREG_IN should be used for regulator output to optimise performance.
- (c) Regulator output connected to 47nF pure and 4.7μF 2.2Ω ESR capacitors.
- (d) Frequency range is 100Hz to 100kHz.
- (e) 1mA to 70mA pulsed load.
- (f) Low power mode is entered and exited automatically when the chip enters/leaves Deep Sleep mode.
- (g) The linear regulator is disabled when VREG_IN is either open circuit or driven to the same voltage as VDD_ANA. If the firmware does not latch the regulator internally, the regulator is also disabled when VREG_ENABLE is pulled low.

3.4 Switch-mode Regulator

Switch-mode Regulator	Min	Typ	Max	Unit
Input voltage	2.5	-	4.2	V
Output voltage ($I_{load} = 70\text{ mA}$)	1.70	1.78	1.9	V
Temperature coefficient	-250	-	+250	ppm/°C
Normal Operation				
Output ripple	-	-	1	mV rms
Transient settling time ^(a)	-	-	50	μs
Maximum load current	100	-	-	mA
Conversion efficiency ($I_{load} 70\text{ mA}$)	-	90	-	%
Switching frequency ^(b)	-	1.333	-	MHz
Start-up current limit ^(c)	-	60	-	mA
Low Power Mode^(d)				
Output ripple	-	-	1	mV rms
Transient settling time ^(e)	-	-	700	μs
Maximum load current	20	-	-	mA
Minimum load current	0	-	-	μA
Conversion efficiency ($I_{load} 1\text{ mA}$)	-	80	-	%
Switching frequency ^(f)	50	-	150	kHz
Disabled Mode				
Quiescent Current	-	-	1	μA

- (a) 1mA to 70mA pulsed load
- (b) Locked to crystal frequency
- (c) Current is limited on start-up to prevent excessive stored energy in the filter inductor. The regulator will operate with reduced efficiency until the current limiter is disabled during the firmware boot-up sequence
- (d) Low power mode is entered and exited automatically when the chip enters/leaves Deep Sleep mode
- (e) 100μA to 1mA pulsed load
- (f) Defines minimum period between pulses. Pulses are skipped at low current loads

3.5 Battery Charger

Battery Charger	Min	Typ	Max	Unit
Input voltage	4.5	-	6.5	V
Charging Mode (BAT_P rising to 4.2V)				
Supply current ^(a)	-	2	-	mA
Flat battery charge current ^(b)	-	4	-	mA
Battery trickle charge current ^{(c) (d)}				
Maximum setting (I-CTRL=15):	-	10	-	mA
Minimum setting (I-CTRL=0):	-	2.5	-	mA
Maximum battery fast charge current (I-CTRL =15) ^{(e) (d)}				
Headroom ^(f) > 0.7V:	-	100	-	mA
Headroom ^(f) = 0.3V:	-	50	-	mA
Minimum battery fast charge current (I-CTRL=0) ^{(e) (d)}				
Headroom ^(f) > 0.7V:	-	25	-	mA
Headroom ^(f) = 0.3V:	-	15	-	mA
Trickle charge voltage threshold	-	2.9	-	V
Float voltage (with correct trim value set) ^(g)	4.17	4.2	4.23	V
Float voltage trim step size ^(g)	-	50	-	mV
Battery charge termination current ^(h)	-	10	-	%
Standby Mode (BAT_P falling from 4.2V)				
Supply current ^(a)	-	80	-	μA
Battery current	-	-40	-	μA
Battery recharge hysteresis ⁽ⁱ⁾	100	-	200	mV
Shutdown Mode (V_CHG too low)				
V_CHG under-voltage threshold				
(V_CHG rising):	-	3.9	-	V
(V_CHG falling):	-	3.7	-	V
V_CHG - BAT_P lockout threshold				
(V_CHG rising):	-	0.22	-	V
(V_CHG falling):	-	0.17	-	V
Supply current	-	-	100	μA
Battery current	-1	-	0	μA

(a) Current into V_CHG - does not include current delivered to battery (I (V_CHG) - I (BAT_P))

(b) BAT_P < 1.8V approx.

(c) 1.8V < BAT_P < Float voltage

(d) Charge current can be set in 16 equally spaced steps, under the control of a register setting I-CTRL

(e) Trickle charge threshold < BAT_P < Float voltage

(f) Headroom is defined as the difference between the V_CHG and BAT_P voltages

(g) Float voltage can be adjusted in 15 steps. Trim setting is determined in production test and must be loaded into the battery charger by firmware during boot-up sequence

(h) Specified as a percentage of the Fast charge current

(i) Hysteresis of ($V_{\text{FLOAT}} - \text{BAT_P}$) for charging to restart

3.6 Digital Terminals

Digital Terminals		Min	Typ	Max	Unit
Input Voltage Levels					
V_{IL} input logic level low	$2.7\text{V} \leq \text{VDD} \leq 3.6\text{V}$	-0.4	-	+0.8	V
	$1.7\text{V} \leq \text{VDD} \leq 1.9\text{V}$	-0.4	-	+0.4	V
V_{IH} input logic level high		0.7VDD	-	$\text{VDD}+0.4$	V
Output Voltage Levels					
V_{OL} output logic level low, ($I_o = 4.0\text{mA}$), $2.7\text{V} \leq \text{VDD} \leq 3.6\text{V}$		-	-	0.2	V
V_{OL} output logic level low, ($I_o = 4.0\text{mA}$), $1.7\text{V} \leq \text{VDD} \leq 1.9\text{V}$		-	-	0.4	V
V_{OH} output logic level high, ($I_o = -4.0\text{mA}$), $2.7\text{V} \leq \text{VDD} \leq 3.6\text{V}$		$\text{VDD}-0.2$	-	-	V
V_{OH} output logic level high, ($I_o = -4.0\text{mA}$), $1.7\text{V} \leq \text{VDD} \leq 1.9\text{V}$		$\text{VDD}-0.4$	-	-	V
Input and Tri-state Current with:					
Strong pull-up		-100	-40	-10	μA
Strong pull-down		+10	+40	+100	μA
Weak pull-up		-5.0	-1.0	-0.2	μA
Weak pull-down		+0.2	+1.0	+5.0	μA
I/O pad leakage current		-1	0	+1	μA
C_1 Input Capacitance		1.0	-	5.0	pF

3.7 USB Terminals

USB Terminals	Min	Typ	Max	Unit
VDD_USB for correct USB operation	3.1		3.6	V
Input Threshold				
V_{IL} input logic level low	-	-	0.3VDD_USB	V
V_{IH} input logic level high	0.7VDD_USB	-	-	V
Input Leakage Current				
$\text{VSS_PADS} < \text{VIN} < \text{VDD_USB}^{(a)}$	-1	1	5	μA
C_1 Input capacitance	2.5	-	10.0	pF
Output Voltage Levels to Correctly Terminated USB Cable				
V_{OL} output logic level low	0.0	-	0.2	V
V_{OH} output logic level high	2.8	-	VDD_USB	V

(a) Internal USB pull-up disabled

3.8 Power on Reset

Power-on Reset	Min	Typ	Max	Unit
VDD_CORE falling threshold	1.40	1.50	1.60	V
VDD_CORE rising threshold	1.50	1.60	1.70	V
Hysteresis	0.05	0.10	0.15	V

3.9 Auxilliary ADC

Auxiliary ADC	Min	Typ	Max	Unit	
Resolution	-	-	8	Bits	
Input voltage range (LSB size = VDD_ANA/255)	0	-	VDD_ANA	V	
Accuracy (Guaranteed monotonic)	INL	-1	-	1	LSB
	DNL	0	-	1	LSB
Offset	-1	-	1	LSB	
Gain Error	-0.8	-	0.8	%	
Input Bandwidth	-	100	-	kHz	
Conversion time	-	2.5	-	µs	
Sample rate ^(a)	-	-	700	Samples/s	

^(a) ADC is accessed through the VM function. The sample rate given is achieved as part of this function.

3.10 Auxilliary DAC

Auxiliary DAC	Min	Typ	Max	Unit
Resolution	-	-	8	Bits
Average output step size ^(a)	12.5	14.5	17.0	mV
Output Voltage		monotonic ^(a)		
Voltage range ($I_O=0mA$)	VSS_PADS	-	VDD_PIO	V
Current range	-10.0	-	0.1	mA
Minimum output voltage ($I_O=100\mu A$)	0.0	-	0.2	V
Maximum output voltage ($I_O=10mA$)	VDD_PIO-0.3	-	VDD_PIO	V
High Impedance leakage current	-1	-	1	μA
Offset	-220	-	120	mV
Integral non-linearity ^(a)	-2	-	2	LSB
Settling time (50pF load)	-	-	10	μs

(a) Specified for an output voltage between 0.2V and VDD_PIO -0.2V. Output is high impedance when chip is in Deep Sleep mode

3.11 Clocks

Crystal Oscillator	Min	Typ	Max	Unit
Crystal frequency ^(a)	8.0	-	32.0	MHz
Digital trim range ^(b)	5.0	6.2	8.0	pF
Trim step size ^(b)	-	0.1	-	pF
Transconductance	2.0	-	-	mS
Negative resistance ^(c)	870	1500	2400	Ω
External Clock				
Input frequency ^(d)	7.5	-	40.0	MHz
Clock input level ^(e)	0.2	-	VDD_ANA	V pk-pk
Allowable Jitter	-	-	15	ps rms
XTAL_IN input impedance	-	-	-	k Ω
XTAL_IN input capacitance	-	7	-	pF

(a) Integer multiple of 250kHz

(b) The difference between the internal capacitance at minimum and maximum settings of the internal digital trim

(c) XTAL frequency = 16MHz; XTAL C0 = 0.75pF; XTAL load capacitance = 8.5pF

(d) Clock input can be any frequency between 8MHz and 40MHz in steps of 250kHz plus CDMA/3G TCXO frequencies of 7.68, 14.44, 15.36, 16.2, 16.8, 19.2, 19.44, 19.68, 19.8 and 38.4MHz

(e) Clock input can be either sinusoidal or square wave. If the peaks of the signal are below VSS_ANA or above VDD_ANA. A DC blocking capacitor is required between the signal and XTAL_IN

3.12 Audio CODEC

Audio CODEC, 15Bit Resolution	Min	Typ	Max	Unit
Microphone Amplifier				
Input full scale at maximum gain	-	3	-	mV rms
Input full scale at minimum gain	-	350	-	mV rms
Gain resolution ^(a)	2.8	3	3.2	dB
Distortion at 1kHz	-	-	-78	dB
Input referenced rms noise ^(b)	-	5	-	μV rms
Bandwidth	-	20	-	kHz
Mic mode input impedance	-	20	-	kΩ
Input mode input impedance	-	130	-	Ω
Analogue to Digital Converter				
Input sample rate ^(c)	-	1	-	MSamples/s
Output sample rate ^(d)	-	8	-	KSamples/s
Distortion and noise at 1kHz (relative to full scale)	-	-78	-75	dB
Digital to Analogue Converter				
Gain resolution	2.8	3	3.2	dB
Min gain ^(e)	-	-18	-	dB
Max gain ^(e)	-	3	-	dB
Loudspeaker Driver				
Output voltage full scale swing (differential)	-	2.0	-	V Pk-Pk
Output current drive (at full scale swing) ^(f)	10	20	40	mA
Output full scale current (at reduced swing) ^(g)	-	75	-	mA
Output -3dB bandwidth	-	18.5	-	kHz
Distortion and noise (relative to full scale) (32Ω load) differential	-	-75	-	dB
Allowed load: resistive	8 ^(h)	-	Open Circuit	Ω
Allowed load: capacitive	-	-	500	pF

(a) 42dB range of gain control (under software control)

(b) Noise in bandwidth from 100Hz to 4kHz gain setting >17dB

(c) Single bit, second order T - Δ ADC clocked at 1MHz

(d) This is the decimated and filtered output at 15-bit resolution

(e) 21dB gain range (under software control)

(f) Output for 0.1%THD, signal level of 2V Pk-Pk differential

(g) Output for 1%THD, signal level of 1V Pk-Pk differential

(h) Output swing reduced to 1.2V Pk-Pk differential with 1%THD or 0.1V Pk-Pk differential with 0.1%THD

3.13 Power Consumption

3.13.1 Typical Average Current

Operation Mode	Connection Type	UART Rate (kbps)	Average	Unit ^(a)
Page scan	-	115.2	0.49	mA
Inquiry and page scan	-	115.2	0.83	mA
ACL No traffic	Master	115.2	4.1	mA
ACL With file transfer	Master	115.2	12	mA
ACL No traffic	Slave	115.2	17	mA
ACL With file transfer	Slave	115.2	21	mA
ACL 40ms sniff	Master	38.4	2.4	mA
ACL 1.28s sniff	Master	38.4	0.37	mA
SCO HV1	Master	38.4	41	mA
SCO HV3	Master	38.4	21	mA
SCO HV3 30ms sniff	Master	38.4	20	mA
ACL 40ms sniff	Slave	38.4	2.1	mA
ACL 1.28s sniff	Slave	38.4	0.42	mA
Parked 1.28s beacon	Slave	38.4	0.20	mA
SCO HV1	Slave	38.4	41	mA
SCO HV3	Slave	38.4	26	mA
SCO HV3 30ms sniff	Slave	38.4	20	mA
Standby Host connection ^(b)	-	38.4	76	μA
Reset (RESETB low) ^(b)	-	-	58	μA

(a) Current measured into the 1V8 supply pins.

(b) Low power mode on the linear regulator is entered and exited automatically when the chip enters/leaves Deep Sleep mode. For more information about the electrical characteristics of the linear regulator, see section 3.3 in this document.

3.13.2 Typical Measurement Conditions

Firmware	HCI 19.2
VREG_IN, VDD_PIO, VDD_PADS	3.15V
Clock source	26MHz crystal
Output power	0dBm

4 Radio Characteristics - Basic Data Rate

Important Note:

BlueCore4-Audio Flash meets the Bluetooth v2.0+EDR specification when used in a suitable application circuit between -40°C and +105°C. TX output is guaranteed unconditionally stable over guaranteed temperature range (between -25°C and +85°C).

4.1 Temperature +20°C

4.1.1 Transmitter

Radio Characteristics	VDD = 1.8V			Temperature = +20°C	
	Min	Typ	Max	Bluetooth Specification	Unit
Maximum RF transmit power ^{(a) (b)}	-	6.0	-	-6 to +4 ^(c)	dBm
RF power variation over temperature range with compensation enabled ^{(±)(d)}	-	1.5	-	-	dB
RF power variation over temperature range with compensation disabled ^{(±)(d)}	-	2.7	-	-	dB
RF power control range	-	35	-	≥16	dB
RF power range control resolution ^(e)	-	0.5	-	-	dB
20dB bandwidth for modulated carrier	-	940	-	≤1000	kHz
Adjacent channel transmit power F = F ₀ ± 2MHz ^{(f) (g)}	-	-45	-	≤-20	dBm
Adjacent channel transmit power F = F ₀ ± 3MHz ^{(f) (g)}	-	-45	-	≤-40	dBm
Adjacent channel transmit power F = F ₀ ± > 3MHz ^{(f) (g)}	-	-50	-	≤-40	dBm
Δf _{1avg} Maximum Modulation	-	164	-	140 < f _{1avg} < 175	kHz
Δf _{2max} Minimum Modulation	-	150	-	≥115	kHz
Δf _{1avg} /Δf _{2avg}	-	0.97	-	≥0.80	-
Initial carrier frequency tolerance	-	5	-	±75	kHz
Drift Rate	-	7	-	≤20	kHz/50μs
Drift (single slot packet)	-	10	-	≤25	kHz
Drift (five slot packet)	-	12	-	≤40	kHz
2 nd Harmonic Content	-	-50	-	≤-30	dBm
3 rd Harmonic Content	-	-45	-	≤-30	dBm

- (a) The BlueCore4-Audio Flash firmware maintains the transmit power within Bluetooth v2.0+EDR specification limits
- (b) Measurement using PSKEY_LC_MAX_TX_POWER setting corresponding to a PSKEY_LC_POWER_TABLE power table entry = 63
- (c) Class 2 RF transmit power range, Bluetooth specification v2.0+EDR
- (d) These parameters are dependent on matching circuit used, and its behaviour over temperature, therefore these parameters are not under CSR's direct control
- (e) Resolution guaranteed over the range -5dB to -25dB relative to maximum power for Tx Level > 20
- (f) Measured at F₀ = 2441MHz
- (g) BlueCore4-Audio Flash guaranteed to meet ACP performance in Bluetooth v2.0+EDR specification, three exceptions allowed

4.1.2 Receiver

Radio Characteristics		VDD = 1.8V			Temperature = +20°C	
	Frequency (GHz)	Min	Typ	Max	Bluetooth Specification	Unit
Sensitivity at 0.1% BER for all packet types	2.402	-	-86.5	-	≤-70	dBm
	2.441	-	-86.5	-		
	2.480	-	-86.5	-		
Maximum received signal at 0.1% BER		-	≥-10	-	≤-20	dBm
	Frequency (MHz)	Min	Typ	Max	Bluetooth Specification	Unit
Continuous power required to block Bluetooth reception (for input power of -67dBm with 0.1% BER) measured at the unbalanced port of the balun.	30-2000	-	≥0	-	≤-10	dBm
	2000-2400	-	-15	-	≤-27	
	2500-3000	-	-15	-	≤-27	
C/I co-channel		-	7	-	≤11	dB
Adjacent channel selectivity C/I F = F ₀ + 1MHz ^(a) (b)		-	-4	-	≤0	dB
Adjacent channel selectivity C/I F = F ₀ - 1MHz ^(a) (b)		-	-3	-	≤0	dB
Adjacent channel selectivity C/I F = F ₀ + 2MHz ^(a) (b)		-	-45	-	≤-30	dB
Adjacent channel selectivity C/I F = F ₀ - 2MHz ^(a) (b)		-	-23	-	≤-20	dB
Adjacent channel selectivity C/I F = F ₀ + 3MHz ^(a) (b)		-	-48	-	≤-40	dB
Adjacent channel selectivity C/I F = F ₀ -5MHz ^(a) (b)		-	-48	-	≤-40	dB
Adjacent channel selectivity C/I F = F _{image} ^(a) (b)		-	-20	-	≤-9	dB
Maximum level of intermodulation interferers ^(c)		-	-15	-	≥-39	dBm
Spurious output level ^(d)		-	≤-130	-	-	dBm/Hz

- (a) Up to five exceptions are allowed in v2.0+EDR of the Bluetooth specification. BlueCore4-Audio Flash is guaranteed to meet the C/I performance as specified by the Bluetooth specification v2.0+EDR
- (b) Measured at F = 2441MHz
- (c) Measured at f₁ - f₂ = 5MHz. Measurement is performed in accordance with Bluetooth RF test RCV/CA/05/c., i.e., wanted signal at -64dBm
- (d) Measured at unbalanced port of the balun. Integrated in 100kHz bandwidth and normalised to 1Hz. Actual figure is typically below -130dBm/Hz except for peaks of -78dBm at 1600MHz, -78dBm inband at 2.4GHz and -78dBm at 3.2GHz

4.2 Temperature -40°C

4.2.1 Transmitter

Radio Characteristics	VDD = 1.8V			Temperature = -40°C	
	Min	Typ	Max	Bluetooth Specification	Unit
Maximum RF transmit power ^(a)	-	7.5	-	-6 to +4 ^(b)	dBm
RF power control range	-	35	-	≥16	dB
RF power range control resolution	-	0.5	-	-	dB
20dB bandwidth for modulated carrier	-	930	-	≤1000	kHz
Adjacent channel transmit power $F = F_0 \pm 2\text{MHz}^{(c)}$ ^(d)	-	-40	-	≤-20	dBm
Adjacent channel transmit power $F = F_0 \pm 3\text{MHz}^{(c)}$ ^(d)	-	-45	-	≤-40	dBm
$\Delta f_{1\text{avg}}$ Maximum Modulation	-	164	-	$140 < \Delta f_{1\text{avg}} < 175$	kHz
$\Delta f_{2\text{max}}$ Minimum Modulation	-	152	-	≥115	kHz
$\Delta f_{2\text{avg}}/\Delta f_{1\text{avg}}$	-	0.97	-	≥0.80	-
Initial carrier frequency tolerance	-	8	-	±75	kHz
Drift Rate	-	7	-	≤20	kHz/50μs
Drift (single slot packet)	-	10	-	≤25	kHz
Drift (five slot packet)	-	12	-	≤40	kHz

(a) BlueCore4-Audio Flash firmware maintains the transmit power to be within the Bluetooth v2.0+EDR specification limits

(b) Class 2 RF transmit power range, Bluetooth v2.0+EDR specification

(c) Measured at $F_0 = 2441\text{MHz}$

(d) Three exceptions are allowed in Bluetooth v2.0+EDR specification

4.2.2 Receiver

Radio Characteristics	Frequency (GHz)	VDD = 1.8V			Temperature = -40°C	
		Min	Typ	Max	Bluetooth Specification	Unit
Sensitivity at 0.1% BER for all packet types	2.402	-	-87.0	-	≤-70	dBm
	2.441	-	-87.5	-		
	2.480	-	-87.5	-		
Maximum received signal at 0.1% BER		-	≥-10.0	-	≥-20	dBm

4.3 Temperature -25°C

4.3.1 Transmitter

Radio Characteristics	VDD = 1.8V			Temperature = -25°C	
	Min	Typ	Max	Bluetooth Specification	Unit
Maximum RF transmit power ^(a)	-	7.0	-	-6 to +4 ^(b)	dBm
RF power control range	-	35	-	≥16	dB
RF power range control resolution	-	0.5	-	-	dB
20dB bandwidth for modulated carrier	-	930	-	≤1000	kHz
Adjacent channel transmit power $F = F_0 \pm 2\text{MHz}^{(c)}$ ^(d)	-	-40	-	≤-20	dBm
Adjacent channel transmit power $F = F_0 \pm 3\text{MHz}^{(c)}$ ^(d)	-	-45	-	≤-40	dBm
$\Delta f_{1\text{avg}}$ Maximum Modulation	-	164	-	$140 < \Delta f_{1\text{avg}} < 175$	kHz
$\Delta f_{2\text{max}}$ Minimum Modulation	-	152	-	≥115	kHz
$\Delta f_{2\text{avg}}/\Delta f_{1\text{avg}}$	-	0.97	-	≥0.80	-
Initial carrier frequency tolerance	-	10	-	±75	kHz
Drift Rate	-	7	-	≤20	kHz/50μs
Drift (single slot packet)	-	12	-	≤25	kHz
Drift (five slot packet)	-	12	-	≤40	kHz

(a) BlueCore4-Audio Flash firmware maintains the transmit power to be within the Bluetooth v2.0+EDR specification limits

(b) Class 2 RF transmit power range, Bluetooth v2.0+EDR specification

(c) Measured at $F_0 = 2441\text{MHz}$

(d) Three exceptions are allowed in Bluetooth v2.0+EDR specification

4.3.2 Receiver

Radio Characteristics	Frequency (GHz)	VDD = 1.8V			Temperature = -25°C	
		Min	Typ	Max	Bluetooth Specification	Unit
Sensitivity at 0.1% BER for all packet types	2.402	-	-86.5	-	≤-70	dBm
	2.441	-	-87.0	-		
	2.480	-	-87.0	-		
Maximum received signal at 0.1% BER		-	≥-10.0	-	≥-20	dBm

4.4 Temperature +85°C

4.4.1 Transmitter

Radio Characteristics	VDD = 1.8V			Temperature = +85°C	
	Min	Typ	Max	Bluetooth Specification	Unit
Maximum RF transmit power ^(a)	-	3.5	-	-6 to +4 ^(b)	dBm
RF power control range	-	35	-	≥16	dB
RF power range control resolution	-	0.5	-	-	dB
20dB bandwidth for modulated carrier	-	930	-	≤1000	kHz
Adjacent channel transmit power $F = F_0 \pm 2\text{MHz}^{(c)}$ ^(d)	-	-42	-	≤-20	dBm
Adjacent channel transmit power $F = F_0 \pm 3\text{MHz}^{(c)}$ ^(d)	-	-45	-	≤-40	dBm
$\Delta f_{1\text{avg}}$ Maximum Modulation	-	164	-	$140 < \Delta f_{1\text{avg}} < 175$	kHz
$\Delta f_{2\text{max}}$ Minimum Modulation	-	149	-	≥115	kHz
$\Delta f_{2\text{avg}}/\Delta f_{1\text{avg}}$	-	0.97	-	≥0.80	-
Initial carrier frequency tolerance	-	15	-	±75	kHz
Drift Rate	-	7	-	≤20	kHz/50μs
Drift (single slot packet)	-	17	-	≤25	kHz
Drift (five slot packet)	-	17	-	≤40	kHz

(a) BlueCore4-Audio Flash firmware maintains the transmit power to be within the Bluetooth v2.0+EDR specification limits

(b) Class 2 RF transmit power range, Bluetooth v2.0+EDR specification

(c) Measured at $F_0 = 2441\text{MHz}$

(d) Three exceptions are allowed in Bluetooth v2.0+EDR specification

4.4.2 Receiver

Radio Characteristics	Frequency (GHz)	VDD = 1.8V			Temperature = +85°C	
		Min	Typ	Max	Bluetooth Specification	Unit
Sensitivity at 0.1% BER for all packet types	2.402	-	-83.5	-	≤-70	dBm
	2.441	-	-84.0	-		
	2.480	-	-84.0	-		
Maximum received signal at 0.1% BER		-	≥-10.0	-	≥-20	dBm

4.5 Temperature +105°C

4.5.1 Transmitter

Radio Characteristics	VDD = 1.8V			Temperature = +105°C	
	Min	Typ	Max	Bluetooth Specification	Unit
Maximum RF transmit power ^(a)	-	2.0	-	-6 to +4 ^(b)	dBm
RF power control range	-	35	-	≥16	dB
RF power range control resolution	-	0.5	-	-	dB
20dB bandwidth for modulated carrier	-	930	-	≤1000	kHz
Adjacent channel transmit power $F = F_0 \pm 2\text{MHz}^{(c)}$ ^(d)	-	-42	-	≤-20	dBm
Adjacent channel transmit power $F = F_0 \pm 3\text{MHz}^{(c)}$ ^(d)	-	-45	-	≤-40	dBm
$\Delta f_{1\text{avg}}$ Maximum Modulation	-	164	-	$140 < \Delta f_{1\text{avg}} < 175$	kHz
$\Delta f_{2\text{max}}$ Minimum Modulation	-	148	-	≥115	kHz
$\Delta f_{2\text{avg}}/\Delta f_{1\text{avg}}$	-	0.97	-	≥0.80	-
Initial carrier frequency tolerance	-	18	-	±75	kHz
Drift Rate	-	7	-	≤20	kHz/50μs
Drift (single slot packet)	-	18	-	≤25	kHz
Drift (five slot packet)	-	18	-	≤40	kHz

(a) BlueCore4-Audio Flash firmware maintains the transmit power to be within the Bluetooth v2.0+EDR specification limits

(b) Class 2 RF transmit power range, Bluetooth v2.0+EDR specification

(c) Measured at $F_0 = 2441\text{MHz}$

(d) Three exceptions are allowed in the Bluetooth v2.0+EDR specification

4.5.2 Receiver

Radio Characteristics	Frequency (GHz)	VDD = 1.8V			Temperature = +105°C	
		Min	Typ	Max	Bluetooth Specification	Unit
Sensitivity at 0.1% BER for all packet types	2.402	-	-83.0	-	≤-70	dBm
	2.441	-	-83.5	-		
	2.480	-	-83.5	-		
Maximum received signal at 0.1% BER		-	≥-10.0	-	≥-20	dBm

5 Radio Characteristics - Enhanced Data Rate

Important Note:

Results shown are referenced to the unbalanced port of the balun.

5.1 Temperature +20°C

5.1.1 Transmitter

Radio Characteristics		VDD = 1.8V		Temperature = +20°C		
		Min	Typ	Max	Bluetooth Specification	Unit
Maximum RF transmit power ^(a)		-	3.5	-	-6 to +4 ^(b)	dBm
Relative transmit power ^(c)		-	-1.0	-	-4 to +1	dB
$\pi/4$ DQPSK max carrier frequency stability ^(c) w_0		-	-2.0	-	$\leq \pm 10$ for all blocks	kHz
$\pi/4$ DQPSK max carrier frequency stability ^(c) w_i		-	0.0	-	$\leq \pm 75$ for all blocks	kHz
$\pi/4$ DQPSK max carrier frequency stability ^(c) $ w_0 + w_i $		-	-2.0	-	$\leq \pm 75$ for all blocks	kHz
8DPSK max carrier frequency stability ^(c) w_0		-	-2.0	-	$\leq \pm 10$ for all blocks	kHz
8DPSK max carrier frequency stability ^(c) w_i		-	-1.0	-	$\leq \pm 75$ for all blocks	kHz
8DPSK max carrier frequency stability ^(c) $ w_0 + w_i $		-	-2.0	-	$\leq \pm 75$ for all blocks	kHz
$\pi/4$ DQPSK Modulation Accuracy ^{(c) (d)}	RMS DEVM	-	6	-	≤ 20	%
	99% DEVM ≤ 0.3	-	100	-	≥ 99	%
	Peak DEVM	-	15	-	≤ 35	%
8DPSK Modulation Accuracy ^{(c) (d)}	RMS DEVM	-	6	-	≤ 13	%
	99% DEVM ≤ 0.2	-	100	-	≥ 99	%
	Peak DEVM	-	14	-	≤ 25	%
In-band spurious emissions ^(e)	$F > F_0 + 3\text{MHz}$	-	-50	-	≤ -40	dBm
	$F < F_0 - 3\text{MHz}$	-	-50	-	≤ -40	dBm
	$F = F_0 - 3\text{MHz}$	-	-45	-	≤ -40	dBm
	$F = F_0 - 2\text{MHz}$	-	-42	-	≤ -20	dBm
	$F = F_0 - 1\text{MHz}$	-	-36	-	≤ -26	dB
	$F = F_0 + 1\text{MHz}$	-	-32	-	≤ -26	dB
	$F = F_0 + 2\text{MHz}$	-	-32	-	≤ -20	dBm
	$F = F_0 + 3\text{MHz}^{(e)}$	-	-38	-	≤ -40	dBm
EDR Differential Phase Encoding		99	No Errors	-	≥ 99	%

(a) BlueCore4-Audio Flash firmware maintains transmit power within Bluetooth v2.0 + EDR specification limits

(b) Class 2 RF transmit power range, Bluetooth v2.0 + EDR specification

(c) Measurements methods are in accordance with the Bluetooth v2.0 + EDR specification

(d) Modulation accuracy utilises differential error vector magnitude (DEVM) with tracking of the frequency drift

(e) Bluetooth specification values are for 8DPSK. Three exceptions are allowed in Bluetooth v2.0 + EDR specification

5.1.2 Receiver

Radio Characteristics						
VDD = 1.8V		Temperature = +20°C				
	Modulation	Min	Typ	Max	Bluetooth Specification	Unit
Sensitivity at 0.01% BER ^(a)	$\pi/4$ DQPSK	-	-86		≤ -70	dBm
	8DPSK	-	-79	-	≤ -70	dBm
Maximum received signal at 0.1% BER ^(a)	$\pi/4$ DQPSK	-	≥ -10	-	≥ -20	dBm
	8DPSK	-	≥ -10	-	≥ -20	dBm
C/I co-channel at 0.1% BER ^(a)	$\pi/4$ DQPSK	-	8	-	$\leq +13$	dB
	8DPSK	-	15	-	$\leq +21$	dB
Adjacent channel selectivity	$\pi/4$ DQPSK	-	-1	-	≤ 0	dB
C/I $F=F_0+1\text{MHz}$ ^{(a) (b) (c)}	8DPSK	-	4	-	$\leq +5$	dB
Adjacent channel selectivity	$\pi/4$ DQPSK	-	-1	-	≤ 0	dB
C/I $F=F_0-1\text{MHz}$ ^{(a) (b) (c)}	8DPSK	-	4	-	$\leq +5$	dB
Adjacent channel selectivity	$\pi/4$ DQPSK	-	-38	-	≤ -30	dB
C/I $F=F_0+2\text{MHz}$ ^{(a) (b) (c)}	8DPSK	-	-35	-	≤ -25	dB
Adjacent channel selectivity	$\pi/4$ DQPSK	-	-22	-	≤ -20	dB
C/I $F=F_0-2\text{MHz}$ ^{(a) (b) (c)}	8DPSK	-	-21	-	≤ -13	dB
Adjacent channel selectivity	$\pi/4$ DQPSK	-	-49	-	≤ -40	dB
C/I $F=F_0+3\text{MHz}$ ^{(a) (b) (c)}	8DPSK	-	-43	-	≤ -33	dB
Adjacent channel selectivity	$\pi/4$ DQPSK	-	-45	-	≤ -40	dB
C/I $F=F_0-5\text{MHz}$ ^{(a) (b) (c)}	8DPSK	-	-38	-	≤ -33	dB
Adjacent channel selectivity	$\pi/4$ DQPSK	-	-19	-	≤ -7	dB
C/I $F=F_{\text{image}}$ ^{(a) (b) (c)}	8DPSK	-	-12	-	≤ 0	dB

(a) Measurements methods are in accordance with the Bluetooth v2.0 + EDR specification

(b) Up to five exceptions are allowed in the Bluetooth v2.0 + EDR specification. BlueCore4-Audio Flash is guaranteed to meet the C/I performance as specified by the Bluetooth v2.0 + EDR

(c) Measured at $F_0 = 2405\text{MHz}, 2441\text{MHz}, 2477\text{MHz}$

5.2 Temperature -40°C

5.2.1 Transmitter

Radio Characteristics		VDD = 1.8V	Temperature = -40°C			Bluetooth Specification	Unit
		Min	Typ	Max			
Maximum RF transmit power ^(a)		-	5.5	-	-6 to +4 ^(b)	dBm	
Relative transmit power ^(c)		-	-1.5	-	-4 to +1	dB	
$\pi/4$ DQPSK max carrier frequency stability ^(c) w_0		-	-3.0	-	$\leq \pm 10$ for all blocks	kHz	
$\pi/4$ DQPSK max carrier frequency stability ^(c) w_i		-	0.9	-	$\leq \pm 75$ for all blocks	kHz	
$\pi/4$ DQPSK max carrier frequency stability ^(c) $ w_0 + w_i $		-	-2.0	-	$\leq \pm 75$ for all blocks	kHz	
8DPSK max carrier frequency stability ^(c) w_0		-	-2.0	-	$\leq \pm 10$ for all blocks	kHz	
8DPSK max carrier frequency stability ^(c) w_i		-	0.0	-	$\leq \pm 75$ for all blocks	kHz	
8DPSK max carrier frequency stability ^(c) $ w_0 + w_i $		-	-2.0	-	$\leq \pm 75$ for all blocks	kHz	
$\pi/4$ DQPSK Modulation Accuracy ^(c) (d)	RMS DEVM	-	6	-	≤ 20	%	
	99% DEVM ≤ 0.3	-	100	-	≥ 99	%	
	Peak DEVM	-	14	-	≤ 35	%	
8DPSK Modulation Accuracy ^(c) (d)	RMS DEVM	-	6	-	≤ 13	%	
	99% DEVM ≤ 0.2	-	100	-	≥ 99	%	
	Peak DEVM	-	14	-	≤ 25	%	
In-band spurious emissions ^(e)	$F > F_0 + 3\text{MHz}$	-	-50	-	≤ -40	dBm	
	$F < F_0 - 3\text{MHz}$	-	-50	-	≤ -40	dBm	
	$F = F_0 - 3\text{MHz}$ ^(e)	-	-40	-	≤ -40	dBm	
	$F = F_0 - 2\text{MHz}$	-	-35	-	≤ -20	dBm	
	$F = F_0 - 1\text{MHz}$	-	-34	-	≤ -26	dB	
	$F = F_0 + 1\text{MHz}$	-	-29	-	≤ -26	dB	
	$F = F_0 + 2\text{MHz}$	-	-26	-	≤ -20	dBm	
$F = F_0 + 3\text{MHz}$ ^(e)	-	-36	-	≤ -40	dBm		
EDR Differential Phase Encoding		99	No Errors	-	≥ 99	%	

- (a) BlueCore4-Audio Flash firmware maintains transmit power within Bluetooth v2.0+EDR specification limits
- (b) Class 2 RF transmit power range, Bluetooth v2.0+EDR specification
- (c) Measurements methods are in accordance with the Bluetooth v2.0 + EDR specification
- (d) Modulation accuracy utilises differential error vector magnitude (DEVM) with tracking of the frequency drift
- (e) The Bluetooth specification values are for 8DPSK. Up to three exceptions are allowed in the Bluetooth v2.0 + EDR specification

5.2.2 Receiver

Radio Characteristics						
VDD = 1.8V Temperature = -40°C						
	Modulation	Min	Typ	Max	Bluetooth Specification	Unit
Sensitivity at 0.01% BER ^(a)	$\pi/4$ DQPSK	-	-88	-	≤ -70	dBm
	8DPSK	-	-80	-	≤ -70	dBm
Maximum received signal at 0.1% BER ^(a)	$\pi/4$ DQPSK	-	≥ -10	-	≥ -20	dBm
	8DPSK	-	≥ -10	-	≥ -20	dBm

^(a) Measurements methods are in accordance with the Bluetooth v2.0 + EDR specification

5.3 Temperature -25°C

5.3.1 Transmitter

Radio Characteristics		VDD = 1.8V	Temperature = -25°C			Bluetooth Specification	Unit
		Min	Typ	Max			
Maximum RF transmit power ^(a)		-	5.0	-	-6 to +4 ^(b)	dBm	
Relative transmit power ^(c)		-	-1.4	-	-4 to +1	dB	
$\pi/4$ DQPSK max carrier frequency stability ^(c) w_0		-	-3.0	-	$\leq \pm 10$ for all blocks	kHz	
$\pi/4$ DQPSK max carrier frequency stability ^(c) w_i		-	0.0	-	$\leq \pm 75$ for all blocks	kHz	
$\pi/4$ DQPSK max carrier frequency stability ^(c) $ w_0 + w_i $		-	-2.0	-	$\leq \pm 75$ for all blocks	kHz	
8DPSK max carrier frequency stability ^(c) w_0		-	-2.0	-	$\leq \pm 10$ for all blocks	kHz	
8DPSK max carrier frequency stability ^(c) w_i		-	0.0	-	$\leq \pm 75$ for all blocks	kHz	
8DPSK max carrier frequency stability ^(c) $ w_0 + w_i $		-	-2.0	-	$\leq \pm 75$ for all blocks	kHz	
$\pi/4$ DQPSK Modulation Accuracy ^{(c) (d)}	RMS DEVM	-	6.0	-	≤ 20	%	
	99% DEVM ≤ 0.3	-	100	-	≥ 99	%	
	Peak DEVM	-	14.0	-	≤ 35	%	
8DPSK Modulation Accuracy ^{(c) (d)}	RMS DEVM	-	6.0	-	≤ 13	%	
	99% DEVM ≤ 0.2	-	100	-	≥ 99	%	
	Peak DEVM	-	14.0	-	≤ 25	%	
In-band spurious emissions ^(e)	$F > F_0 + 3\text{MHz}$	-	-50	-	≤ -40	dBm	
	$F < F_0 - 3\text{MHz}$	-	-50	-	≤ -40	dBm	
	$F = F_0 - 3\text{MHz}$	-	-45	-	≤ -40	dBm	
	$F = F_0 - 2\text{MHz}$	-	-38	-	≤ -20	dBm	
	$F = F_0 - 1\text{MHz}$	-	-34	-	≤ -26	dB	
	$F = F_0 + 1\text{MHz}$	-	-32	-	≤ -26	dB	
	$F = F_0 + 2\text{MHz}$	-	-28	-	≤ -20	dBm	
$F = F_0 + 3\text{MHz}$ ^(e)	-	-36	-	≤ -40	dBm		
EDR Differential Phase Encoding		99	No Errors	-	≥ 99	%	

- (a) BlueCore4-Audio Flash firmware maintains transmit power within Bluetooth v2.0 + EDR specification limits
- (b) Class 2 RF transmit power range, Bluetooth v2.0 + EDR specification
- (c) Measurements methods are in accordance with the Bluetooth v2.0 + EDR specification
- (d) Modulation accuracy utilises differential error vector magnitude (DEVM) with tracking of the frequency drift
- (e) The Bluetooth specification values are for D8PSK. Up to three exceptions are allowed in the Bluetooth v2.0 + EDR specification

5.3.2 Receiver

Radio Characteristics						
VDD = 1.8V Temperature = -25°C						
	Modulation	Min	Typ	Max	Bluetooth Specification	Unit
Sensitivity at 0.01% BER ^(a)	$\pi/4$ DQPSK	-	-87	-	≤ -70	dBm
	8DPSK	-	-80	-	≤ -70	dBm
Maximum received signal at 0.1% BER ^(a)	$\pi/4$ DQPSK	-	≥ -10	-	≥ -20	dBm
	8DPSK	-	≥ -10	-	≥ -20	dBm

^(a) Measurements methods are in accordance with the Bluetooth v2.0 + EDR specification

5.4 Temperature +85°C

5.4.1 Transmitter

Radio Characteristics		VDD = 1.8V		Temperature = +85°C		
		Min	Typ	Max	Bluetooth Specification	Unit
Maximum RF transmit power ^(a)		-	3.5	-	-6 to +4 ^(b)	dBm
Relative transmit power ^(c)		-	-1.2	-	-4 to +1	dB
$\pi/4$ DQPSK max carrier frequency stability ^(c) w_0		-	1.0	-	$\leq \pm 10$ for all blocks	kHz
$\pi/4$ DQPSK max carrier frequency stability ^(c) w_i		-	1.0	-	$\leq \pm 75$ for all blocks	kHz
$\pi/4$ DQPSK max carrier frequency stability ^(c) $ w_0 + w_i $		-	-1.0	-	$\leq \pm 75$ for all blocks	kHz
8DPSK max carrier frequency stability ^(c) w_0		-	2.0	-	$\leq \pm 10$ for all blocks	kHz
8DPSK max carrier frequency stability ^(c) w_i		-	1.0	-	$\leq \pm 75$ for all blocks	kHz
8DPSK max carrier frequency stability ^(c) $ w_0 + w_i $		-	-1.0	-	$\leq \pm 75$ for all blocks	kHz
$\pi/4$ DQPSK Modulation Accuracy ^(c) (d)	RMS DEVM	-	6	-	≤ 20	%
	99% DEVM ≤ 0.3	99	100	-	≥ 99	%
	Peak DEVM	-	15	-	≤ 35	%
8DPSK Modulation Accuracy ^(c) (d)	RMS DEVM	-	6	-	≤ 13	%
	99% DEVM ≤ 0.2	-	100	-	≥ 99	%
	Peak DEVM	-	16	-	≤ 25	%
In-band spurious emissions ^(e)	$F > F_0 + 3\text{MHz}$	-	-50	-	≤ -40	dBm
	$F < F_0 - 3\text{MHz}$	-	-50	-	≤ -40	dBm
	$F = F_0 - 3\text{MHz}$	-	-50	-	≤ -40	dBm
	$F = F_0 - 2\text{MHz}$	-	-44	-	≤ -20	dBm
	$F = F_0 - 1\text{MHz}$	-	-38	-	≤ -26	dB
	$F = F_0 + 1\text{MHz}$	-	-32	-	≤ -26	dB
	$F = F_0 + 2\text{MHz}$	-	-34	-	≤ -20	dBm
$F = F_0 + 3\text{MHz}$ ^(e)	-	-40	-	≤ -40	dBm	
EDR Differential Phase Encoding		99	No Errors	-	≥ 99	%

- (a) BlueCore4-Audio Flash firmware maintains transmit power within Bluetooth v2.0 + EDR specification limits
- (b) Class 2 RF transmit power range, Bluetooth v2.0 + EDR specification
- (c) Measurements methods are in accordance with the Bluetooth v2.0 + EDR specification
- (d) Modulation accuracy utilises differential error vector magnitude (DEVM) with tracking of the frequency drift
- (e) The Bluetooth specification values are for 8DPSK. Up to three exceptions are allowed in the Bluetooth v2.0 + EDR specification

5.4.2 Receiver

Radio Characteristics						
VDD = 1.8V Temperature = +85°C						
	Modulation	Min	Typ	Max	Bluetooth Specification	Unit
Sensitivity at 0.01% BER ^(a)	$\pi/4$ DQPSK	-	-84	-	≤ -70	dBm
	8DPSK	-	-76	-	≤ -70	dBm
Maximum received signal at 0.1% BER ^(a)	$\pi/4$ DQPSK	-	≥ -10	-	≥ -20	dBm
	8DPSK	-	≥ -10	-	≥ -20	dBm

^(a) Measurements methods are in accordance with the Bluetooth v2.0 + EDR specification

6 Device Diagram

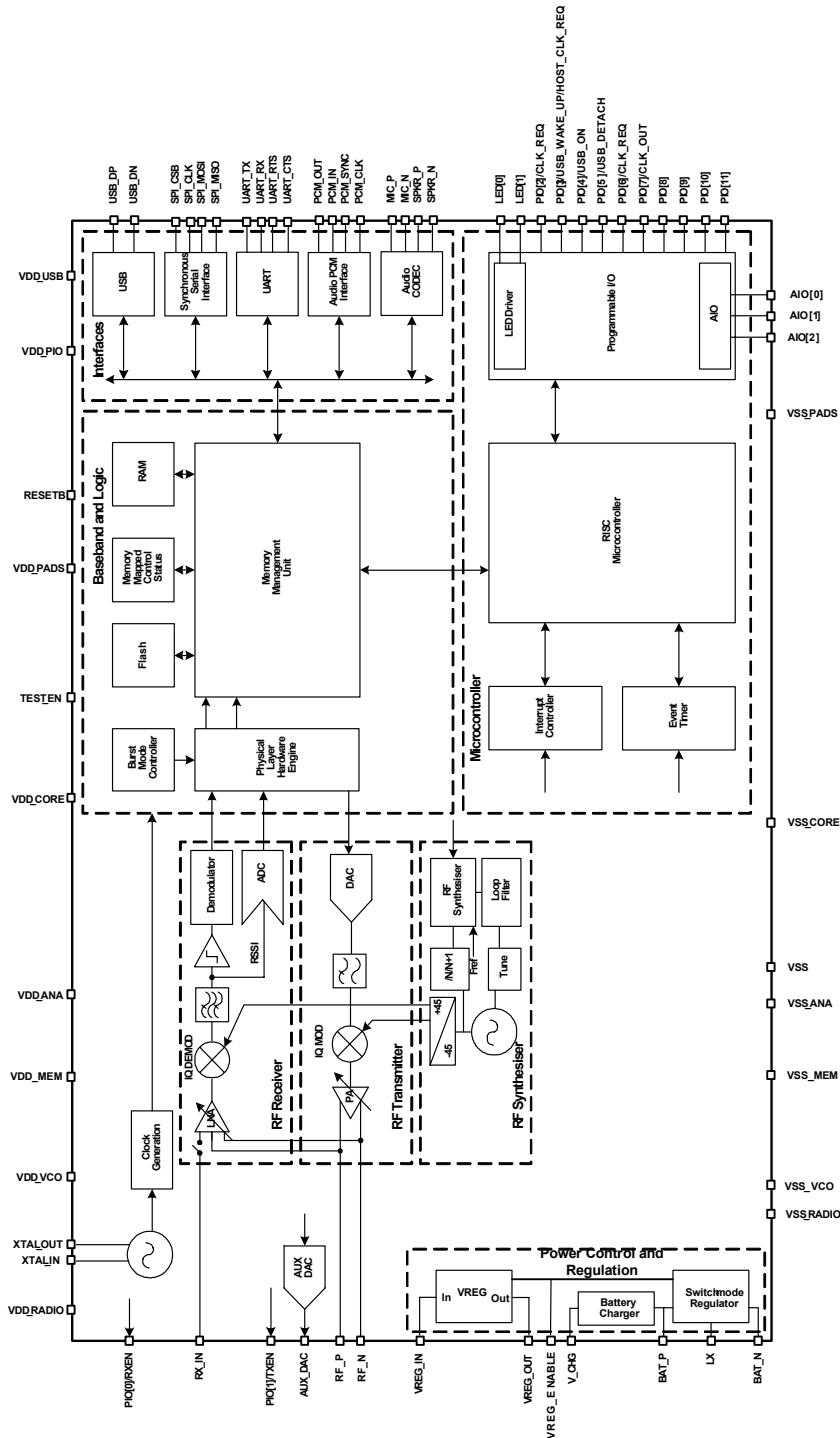

Figure 6.1: BlueCore4-Audio Flash Device Diagram

7 Description of Functional Blocks

7.1 RF Receiver

The receiver features a near-zero *Intermediate Frequency* (IF) architecture that allows the channel filters to be integrated onto the die. Sufficient out-of-band blocking specification at the *Low Noise Amplifier* (LNA) input allows the radio to be used in close proximity to *Global System for Mobile Communications* (GSM) and *Wideband Code Division Multiple Access* (W-CDMA) cellular phone transmitters without being desensitised. The use of a digital *Frequency Shift Keying* (FSK) discriminator means that no discriminator tank is needed and its excellent performance in the presence of noise allows BlueCore4-Audio Flash to exceed the Bluetooth requirements for co-channel and adjacent channel rejection.

For EDR, an ADC is used to digitise the IF received signal.

7.1.1 Low Noise Amplifier

The LNA can be configured to operate in single-ended or differential mode. Single-ended mode is used for Class 1 Bluetooth operation; differential mode is used for Class 2 operation.

7.1.2 Analogue to Digital Converter

The *Analogue to Digital Converter* (ADC) is used to implement fast *Automatic Gain Control* (AGC). The ADC samples the *Received Signal Strength Indicator* (RSSI) voltage on a slot-by-slot basis. The front-end LNA gain is changed according to the measured RSSI value, keeping the first mixer input signal within a limited range. This improves the dynamic range of the receiver, improving performance in interference limited environments.

7.2 RF Transmitter

7.2.1 IQ Modulator

The transmitter features a direct IQ modulator to minimise the frequency drift during a transmit timeslot, which results in a controlled modulation index. Digital baseband transmit circuitry provides the required spectral shaping.

7.2.2 Power Amplifier

The internal *Power Amplifier* (PA) has a maximum output power of +6dBm. This allows BlueCore4-Audio Flash to be used in Class 2 and Class 3 radios without an external RF PA.

Support for transmit power control allows a simple implementation for Class 1 with an external RF PA.

7.3 RF Synthesiser

The radio synthesiser is fully integrated onto the die with no requirement for an external *Voltage Controlled Oscillator* (VCO) screening can, varactor tuning diodes, LC resonators or loop filter. The synthesiser is guaranteed to lock in sufficient time across the guaranteed temperature range to meet the Bluetooth v2.0 + EDR specification.

7.4 Switch-Mode Regulator

BlueCore4-Audio Flash contains a high efficiency step-down switch mode 1.8V regulator, which can be used to power the complete chip from a single Lithium Ion/Polymer battery (or other external voltage source). The circuit has only two external passive filter components and has an internal PID feedback for very low supply ripple.

7.5 Linear Regulator

As an alternative, BlueCore4-Audio Flash also contains a 1.8V linear regulator which can be used to power the complete chip. This is less efficient than the switch-mode regulator, but requires less space for external components and can run at lower input voltages. If the switch mode regulator is used to power the chip, the linear regulator can be used to provide an internal low noise bias circuit for a microphone.

7.6 Battery Charger

BlueCore4-Audio Flash contains a fully integrated battery charger circuit, suitable for charging a Lithium Ion/Polymer battery. The circuit requires no external components.

7.7 Clock Input and Generation

The reference clock for the system is generated from a TCXO or crystal input between 8MHz and 40MHz. All internal reference clocks are generated using a phase locked loop, which is locked to the external reference frequency.

7.8 Baseband and Logic

7.8.1 Memory Management Unit

The *Memory Management Unit* (MMU) provides a number of dynamically allocated ring buffers that hold the data that is in transit between the host and the air. The dynamic allocation of memory ensures efficient use of the available *Random Access Memory* (RAM) and is performed by a hardware MMU to minimise the overheads on the processor during data/voice transfers.

7.8.2 Burst Mode Controller

During radio transmission the *Burst Mode Controller* (BMC) constructs a packet from header information previously loaded into memory-mapped registers by the software and payload data/voice taken from the appropriate ring buffer in the RAM. During radio reception, the BMC stores the packet header in memory-mapped registers and the payload data in the appropriate ring buffer in RAM. This architecture minimises the intervention required by the processor during transmission and reception.

7.8.3 Physical Layer Hardware Engine DSP

Dedicated logic is used to perform the following:

- Forward error correction
- Header error control
- Cyclic redundancy check
- Encryption
- Data whitening
- Access code correlation
- Audio transcoding

The following voice data translations and operations are performed by firmware:

- A-law/ μ -law/linear voice data (from host)
- A-law/ μ -law/*Continuously Variable Slope Delta* (CVSD) (over the air)
- Voice interpolation for lost packets
- Rate mismatches

The hardware supports all optional and mandatory features of Bluetooth v2.0 + EDR including AFH and eSCO.

7.8.4 System RAM

48KB of on-chip RAM is provided to support the RISC MCU and is shared between the ring buffers used to hold voice/data for each active connection and the general purpose memory required by the Bluetooth stack.

7.8.5 Flash Memory (6Mbit)

6Mbits of internal Flash is available on BlueCore4-Audio Flash. The Flash memory is provided for system firmware. There are three pads for testing the Flash memory, these should not be connected.

7.8.6 USB

This is a full speed Universal Serial Bus (USB) interface for communicating with other compatible digital devices. BlueCore4-Audio Flash acts as a USB peripheral, responding to requests from a master host controller such as a PC.

7.8.7 Synchronous Serial Interface

This is a synchronous serial port interface (SPI) for interfacing with other digital devices. The SPI port can be used for system debugging. It can also be used for programming the Flash memory.

7.8.8 UART

This is a standard *Universal Asynchronous Receiver Transmitter* (UART) interface for communicating with other serial devices.

7.9 Microcontroller

The *microcontroller unit* (MCU), interrupt controller and event timer run the Bluetooth software stack and control the radio and host interfaces. A 16-bit reduced instruction set computer (RISC) microcontroller is used for low power consumption and efficient use of memory.

7.9.1 Programmable I/O

BlueCore4-Audio Flash has a total of 15 (12 digital and 3 analogue) programmable I/O terminals. These are controlled by firmware running on the device.

7.9.2 PCM Interface

The audio PCM interface supports continuous transmission and reception of PCM encoded voice data over Bluetooth. It also contains support for PCM master CODECs that require an external system clock. The interface shares the same pins as the digital audio interface.

7.9.3 Audio CODEC

BlueCore4-Audio Flash has a 15-bit Audio CODEC that has a 8kHz sampling frequency. This has been designed for use in voice applications such as headsets and hands-free kits. The CODEC has integrated input/output amplifiers capable of driving a microphone and speaker with minimum external components.

7.9.4 LED Driver

Two LED output pads are provided to control LED indicators. The pads are open drain pull-downs, controlled by firmware running on the device. LED[0] is hard wired to indicate battery charging, but this feature can be overridden in firmware.

8 Device Terminal Descriptions

8.1 RF Ports

The BlueCore4-Audio Flash RF_IN terminal can be configured as either a single-ended or differential input. The operational mode is determined by setting PSKEY_TXRX_PIO_CONTROL (0x20).

8.1.1 RF_P and RF_N

RF_P and RF_N form a complementary balanced pair. On transmit, their outputs are combined using a balun into the single-ended output required for the antenna. Similarly, on receive, their input signals are combined internally. Both terminals present similar complex impedances that require matching networks between them and the balun. Starting from the substrate (chip) side, the outputs can each be modelled as an ideal current source in parallel with a lossy resistance and a capacitor. The bond wire can be represented as series inductance.

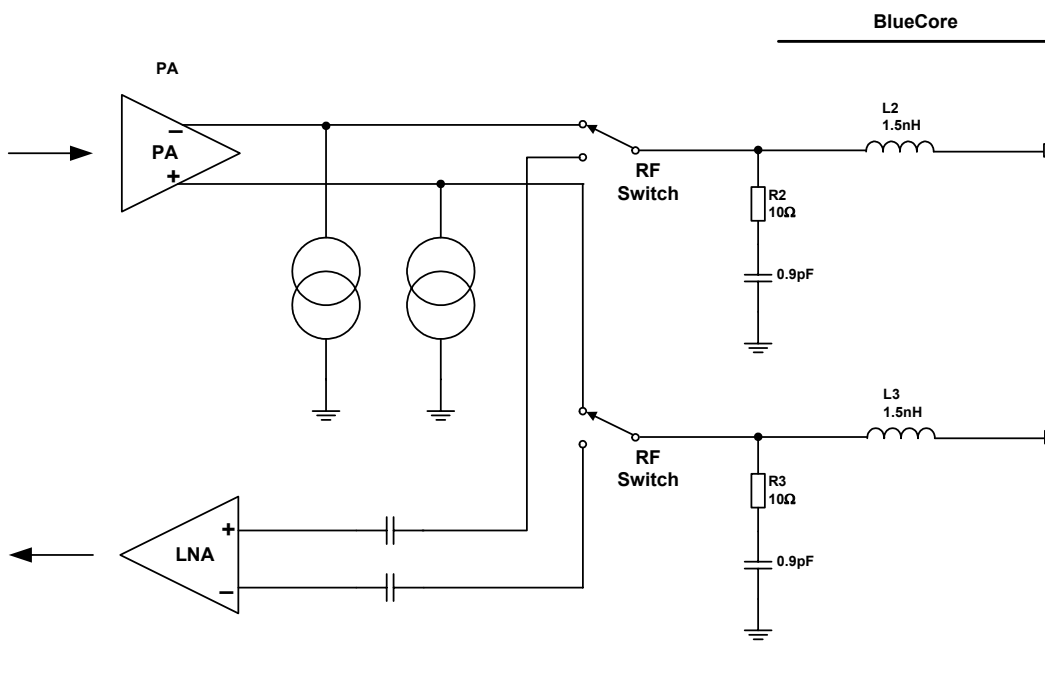

Figure 8.1: Circuit RF_P and RF_N

8.1.2 Single-Ended Input

This is the single-ended RF input from the antenna. The input presents a complex impedance that requires a matching network between the terminal and the antenna. Starting from the substrate (chip) side, the input can be modelled as a lossy capacitor with the bond wire to the ball grid represented as a series inductance.

The terminal is DC blocked. The DC level must not exceed (VSS_RADIO - 0.3V to VDD_RADIO + 0.3V).

8.1.3 Transmit RF Power Control for Class 1 Applications (TX_PWR)

An 8-bit voltage DAC (AUX_DAC) is used to control the amplification level of the external PA for Class 1 operation. The DAC output is derived from the on-chip band gap and is virtually independent of temperature and supply voltage. The output voltage is given by:

$$V_{DAC} = \text{MIN} \left(\left(3.3\text{v} \times \frac{\text{CNTRL_WORD}}{255} \right), (VDD_PIO - 0.3\text{v}) \right)$$

Equation 8.1: Output Voltage with Load Current $\leq 10\text{mA}$

for a load current $\leq 10\text{mA}$ (sourced from the device).

or

$$V_{DAC} = \text{MIN} \left(\left(3.3\text{v} \times \frac{\text{CNTRL_WORD}}{255} \right), VDD_PIO \right)$$

Equation 8.2: Output Voltage with No Load Current

for no load current.

BlueCore4-Audio Flash enables the external PA only when transmitting. Before transmitting, the chip normally ramps up the power to the internal PA, then it ramps it down again afterwards. However, if a suitable external PA is used, it may be possible to ramp the power externally by driving the TX_PWR pin on the PA from AUX_DAC.

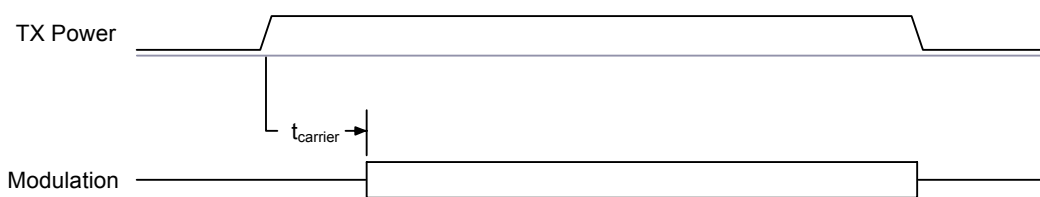

Equation 8.3: Internal Power Ramping

PSKEY_TX_GAINRAMP (0x1d), is used to control the delay (in units of μs) between the end of the transmit power ramp and the start of modulation. In this period the carrier is transmitted, which gives the transmit circuitry time to fully settle to the correct frequency.

Bits[15:8] define a delay, t_{carrier} , (in units of μs) between the end of the transmit power ramp and the start of modulation. In this period the carrier is transmitted, which aids interoperability with some other vendor equipment which is not strictly Bluetooth compliant.

8.1.4 Control of External RF Components

TXRX_PIO_CONTROL (0x209) is used to control external RF components such as a switch, an external PA or an external LNA. PIO[0], PIO[1] and the AUX_DAC can be used for this purpose, as Table 8.1 indicates.

TXRX_PIO_CONTROL Value	AUX_DAC Use
0	PIO[0], PIO[1], AUX_DAC not used to control RF. Power ramping is internal.
1	PIO[0] is high during RX, PIO[1] is high during TX. AUX_DAC not used. Power ramping is internal.
2	PIO[0] is high during RX, PIO[1] is high during TX. AUX_DAC used to set gain of external PA. Power ramping is external.
3	PIO[0] is low during RX, PIO[1] is low during TX. AUX_DAC used to set gain of external PA. Power ramping is external.
4	PIO[0] is high during RX, PIO[1] is high during TX. AUX_DAC used to set gain of external PA. Power ramping is internal.

Table 8.1: TXRX_PIO_CONTROL Values

8.2 External Reference Clock Input (XTAL_IN)

The BlueCore4-Audio Flash RF local oscillator and internal digital clocks are derived from the reference clock at the BlueCore4-Audio Flash XTAL_IN input. This reference may be either an external clock or from a crystal connected between XTAL_IN and XTAL_OUT. The crystal mode is described in section 8.3.

8.2.1 External Mode

BlueCore4-Audio Flash can be configured to accept an external reference clock from another device (such as TCXO) at XTAL_IN by connecting XTAL_OUT to ground. The external clock can be either a digital level square wave or sinusoidal, and this may be directly coupled to XTAL_IN without the need for additional components. If the peaks of the reference clock are below VSS_ANA or above VDD_ANA, it must be driven through a DC blocking capacitor (approximately 33pF) connected to XTAL_IN. A digital level reference clock gives superior noise immunity, as the high slew rate clock edges have lower voltage to phase conversion.

The external clock signal should meet the specifications in Table 8.2:

	Min	Typ	Max
Frequency ^(a)	7.5MHz	16MHz	40MHz
Duty cycle	20:80	50:50	80:20
Edge Jitter (At Zero Crossing)	-	-	15ps rms
Signal Level	400mV pk-pk	-	VDD_ANA ^{(b) (c)}

Table 8.2: External Clock Specifications

- (a) The frequency should be an integer multiple of 250kHz except for the CDMA/3G frequencies
- (b) VDD_ANA is 1.8V nominal
- (c) If the external clock is driven through a DC blocking capacitor, then maximum allowable amplitude is reduced from VDD_ANA to 800mV pk-pk

8.2.2 XTAL_IN Impedance in External Mode

The impedance of the XTAL_IN will not change significantly between operating modes, typically 10fF. When transitioning from Deep Sleep to an active state a spike of up to 1pC may be measured. For this reason it is recommended that a buffered clock input be used.

8.2.3 Clock Timing Accuracy

As Figure 8.2 indicates, the 250ppm timing accuracy on the external clock is required 7ms after the assertion of the system clock request line. This is to guarantee that the firmware can maintain timing accuracy in accordance with the Bluetooth v2.0 + EDR specification. Radio activity may occur after 11ms, therefore, at this point the timing accuracy of the external clock source must be within 20ppm.

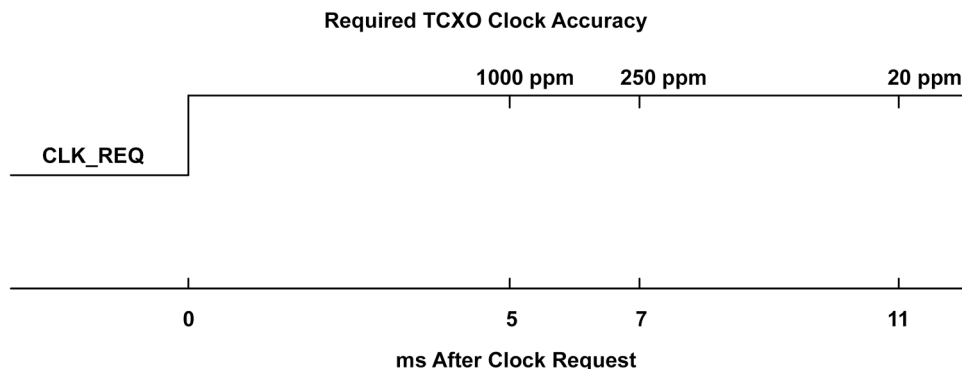

Figure 8.2: TCXO Clock Accuracy

8.2.4 Clock Start-Up Delay

BlueCore4-Audio Flash hardware incorporates an automatic delay after the assertion of the system clock request signal before running firmware. By default, the delay is 5 low-power oscillator (LPO) cycles. At a nominal LPO frequency of 1 kHz, this equates to 5 ms. This is suitable for most applications using an external clock source.

However, there may be scenarios where the clock cannot be guaranteed to either exist or be stable after this period. Under these conditions, BlueCore4-Audio Flash provides a function that alters the system clock request signal to the period stored in `PSKEY_CLOCK_STARTUP_DELAY`. This value is in units of LPO cycles from 1 to 31. Setting the key to zero gives a delay of 5 cycles, the default value.

The nominal frequency of the internal LPO is 1 kHz, however, the value varies somewhat between chips, so care should be taken to pick a suitable value. If an external slow clock at 32 kHz is supplied, this is divided by 32 before use.

This PS Key allows the designer to optimise a system where clock latencies may be longer than 5ms while still keeping the current consumption of BlueCore4-Audio Flash as low as possible. BlueCore4-Audio Flash consumes about 2mA of current for the duration of `PSKEY_CLOCK_STARTUP_DELAY` before activating the firmware.

8.2.5 Input Frequencies and PS Key Settings

BlueCore4-Audio Flash should be configured to operate with the chosen reference frequency. This is accomplished by setting PSKEY_ANA_FREQ (0x1fe) for all frequencies with an integer multiple of 250kHz. The input frequency default setting in BlueCore4-Audio Flash is 26MHz.

The following CDMA/3G TCXO frequencies are also catered for: 7.68, 14.4, 15.36, 16.2, 16.8, 19.2, 19.44, 19.68, 19.8 and 38.4MHz.

Reference Crystal Frequency (MHz)	PSKEY_ANA_FREQ (0x1fe) (Units of 1kHz)
7.68	7680
14.40	14400
15.36	15360
16.20	16200
16.80	16800
19.20	19200
19.44	19440
19.68	19680
19.80	19800
38.40	38400
n x 250kHz	-
+26.00 Default	26000

Table 8.3: PS Key Values for CDMA/3G Phone TCXO Frequencies

8.3 Crystal Oscillator (XTAL_IN, XTAL_OUT)

This section describes the crystal mode. See section 8.2 for the description of the external reference clock mode.

8.3.1 XTAL Mode

BlueCore4-Audio Flash contains a crystal driver circuit. This operates with an external crystal and capacitors to form a Pierce oscillator.

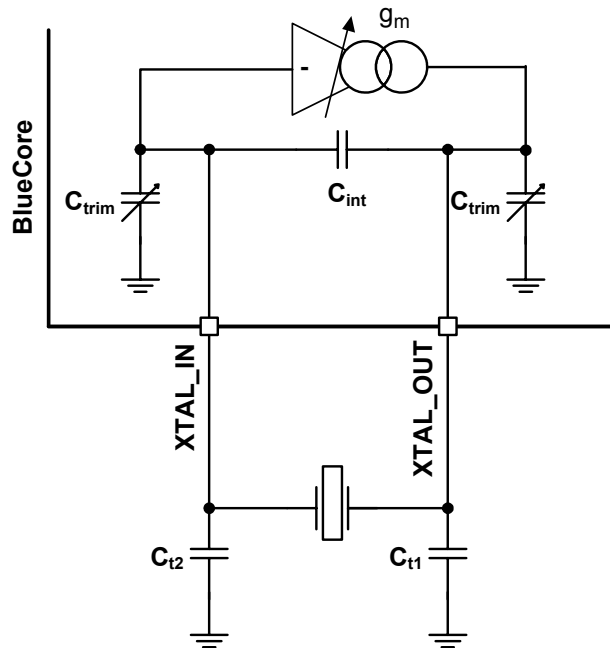

Figure 8.3: Crystal Driver Circuit

Figure 8.4 shows an electrical equivalent circuit for a crystal. The crystal appears inductive near its resonant frequency. It forms a resonant circuit with its load capacitors.

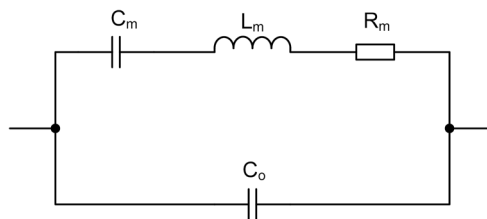

Figure 8.4: Crystal Equivalent Circuit

The resonant frequency may be trimmed with the crystal load capacitance. BlueCore4-Audio Flash contains variable internal capacitors to provide a fine trim.

	Min	Typ	Max
Frequency	8MHz	26MHz	32MHz
Initial Tolerance	-	±25ppm	-
Pullability	-	±20ppm/pF	-

Table 8.4: Crystal Specification

The BlueCore4-Audio Flash driver circuit is a transconductance amplifier. A voltage at XTAL_IN generates a current at XTAL_OUT. The value of transconductance is variable and may be set for optimum performance.

8.3.2 Load Capacitance

For resonance at the correct frequency the crystal should be loaded with its specified load capacitance, which is defined for the crystal. This is the total capacitance across the crystal viewed from its terminals. BlueCore4-Audio Flash provides some of this load with the capacitors C_{trim} and C_{int} . The remainder should be from the external capacitors labelled C_{t1} and C_{t2} . C_{t1} should be three times the value of C_{t2} for best noise performance. This maximises the signal swing, hence, slew rate at XTAL_IN (to which all on-chip clocks are referred). Crystal load capacitance, C_l is calculated with Equation 8.4:

$$C_l = C_{int} + \frac{C_{trim}}{2} + \frac{C_{t1} \cdot C_{t2}}{C_{t1} + C_{t2}}$$

Equation 8.4: Load Capacitance
Where:

C_{trim} = 3.4pF nominal (mid-range setting)

C_{int} = 1.5pF

Note:

C_{int} does not include the crystal internal self capacitance; it is the driver self capacitance.

8.3.3 Frequency Trim

BlueCore4-Audio Flash enables frequency adjustments to be made. This feature is typically used to remove initial tolerance frequency errors associated with the crystal. Frequency trim is achieved by adjusting the crystal load capacitance with on-chip trim capacitors, C_{trim} . The value of C_{trim} is set by a 6-bit word in PSKEY_ANA_FTRIM (0x1F6). Its value is calculated thus:

$$C_{trim} = 110fF \times PSKEY_ANA_FTRIM$$

Equation 8.5: Trim Capacitance

There are two C_{trim} capacitors, which are both connected to ground. When viewed from the crystal terminals, they appear in series so each least significant bit (LSB) increment of frequency trim presents a load across the crystal of 55fF.

The frequency trim is described by Equation 8.6.

$$\frac{\Delta(F_x)}{F_x} = \text{pullability} \times 55 \times 10^{-3} (\text{ppm/LSB})$$

Equation 8.6: Frequency Trim

Where F_x is the crystal frequency and pullability is a crystal parameter with units of ppm/pF. Total trim range is 63 times the value above.

If not specified, the pullability of a crystal may be calculated from its motional capacitance with Equation 8.7.

$$\frac{\partial(F_x)}{\partial(C)} = F_x \cdot \frac{C_m}{2(C_1 + C_0)^2}$$

Equation 8.7: Pullability

Where:

C_0 = Crystal self capacitance (shunt capacitance)

C_m = Crystal motional capacitance (series branch capacitance in crystal model). See Figure 8.4.

Note:

It is a Bluetooth requirement that the frequency is always within ± 20 ppm. The trim range should be sufficient to pull the crystal within ± 5 ppm of the exact frequency. This leaves a margin of ± 15 ppm for frequency drift with ageing and temperature. A crystal with an ageing and temperature drift specification of better than ± 15 ppm is required.

8.3.4 Transconductance Driver Model

The crystal and its load capacitors should be viewed as a transimpedance element, whereby a current applied to one terminal generates a voltage at the other. The transconductance amplifier in BlueCore4-Audio Flash uses the voltage at its input, XTAL_IN, to generate a current at its output, XTAL_OUT. Therefore, the circuit will oscillate if the transconductance, transimpedance product is greater than unity. For sufficient oscillation amplitude, the product should be greater than three. The transconductance required for oscillation is defined by the relationship shown in Equation 8.8:

$$g_m > \frac{3(2\pi F_x)^2 R_m ((C_0 + C_{int})(C_{t1} + C_{t2} + C_{trim}) + (C_{t1} + C_{trim})(C_{t2} + C_{trim}))^2}{(C_{t1} + C_{trim})(C_{t2} + C_{trim})}$$

Equation 8.8: Transconductance Required for Oscillation

BlueCore4-Audio Flash guarantees a transconductance value of at least 2mA/V at maximum drive level.

Notes:

More drive strength is required for higher frequency crystals, higher loss crystals (larger R_m) or higher capacitance loading.

Optimum drive level is attained when the level at XTAL_IN is approximately 1V pk-pk. The drive level is determined by the crystal driver transconductance, by setting PSKEY_XTAL_LVL (0x241).

8.3.5 Negative Resistance Model

An alternative representation of the crystal and its load capacitors is a frequency dependent resistive element. The driver amplifier may be considered as a circuit that provides negative resistance. For oscillation, the value of the negative resistance must be greater than that of the crystal circuit equivalent resistance. Although the BlueCore4-Audio Flash crystal driver circuit is based on a transimpedance amplifier, an equivalent negative resistance may be calculated for it with the following formula in Equation 8.9:

$$R_{neg} > \frac{(C_{t1} + C_{trim})(C_{t2} + C_{trim})}{g_m (2\pi F_x)^2 ((C_0 + C_{int})(C_{t1} + C_{t2} + 2C_{trim}) + (C_{t1} + C_{trim})(C_{t2} + C_{trim}))^2}$$

Equation 8.9: Equivalent Negative Resistance

This formula shows the negative resistance of the BlueCore4-Audio Flash driver as a function of its drive strength.

The value of the driver negative resistance may be easily measured by placing an additional resistance in series with the crystal. The maximum value of this resistor (oscillation occurs) is the equivalent negative resistance of the oscillator.

8.3.6 Crystal PS Key Settings

See tables in section 8.2.5.

8.3.7 Crystal Oscillator Characteristics

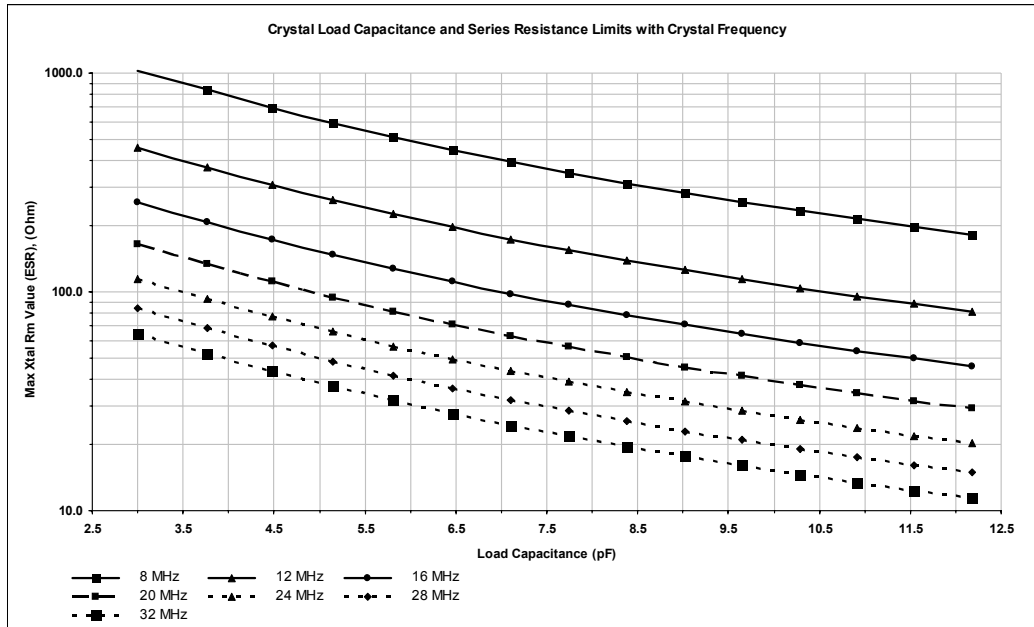

Figure 8.5: Crystal Load Capacitance and Series Resistance Limits with Crystal Frequency

Note:

Graph shows results for BlueCore4-Audio Flash crystal driver at maximum drive level.

Conditions:

- $C_{trim} = 3.4\text{pF}$ centre value
- Crystal $C_o = 2\text{pF}$
- Transconductance setting = 2mA/V
- Loop gain = 3
- $C_{t1}/C_{t2} = 3$

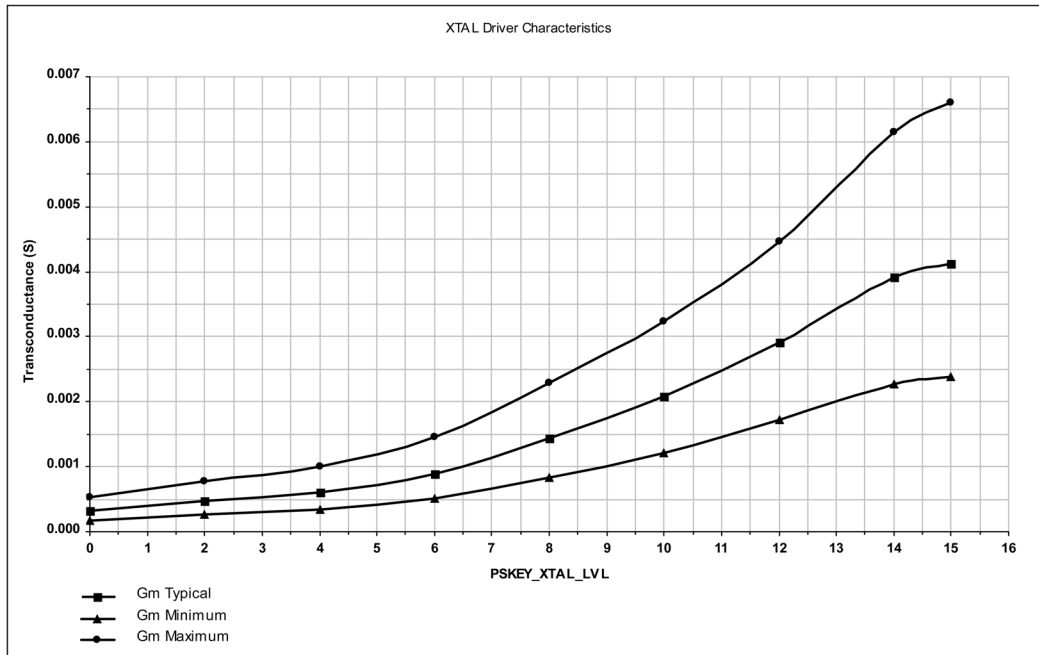

Figure 8.6: Crystal Driver Transconductance vs. Driver Level Register Setting

Note:

Drive level is set by PSKEY_XTAL_LVL (0x241).

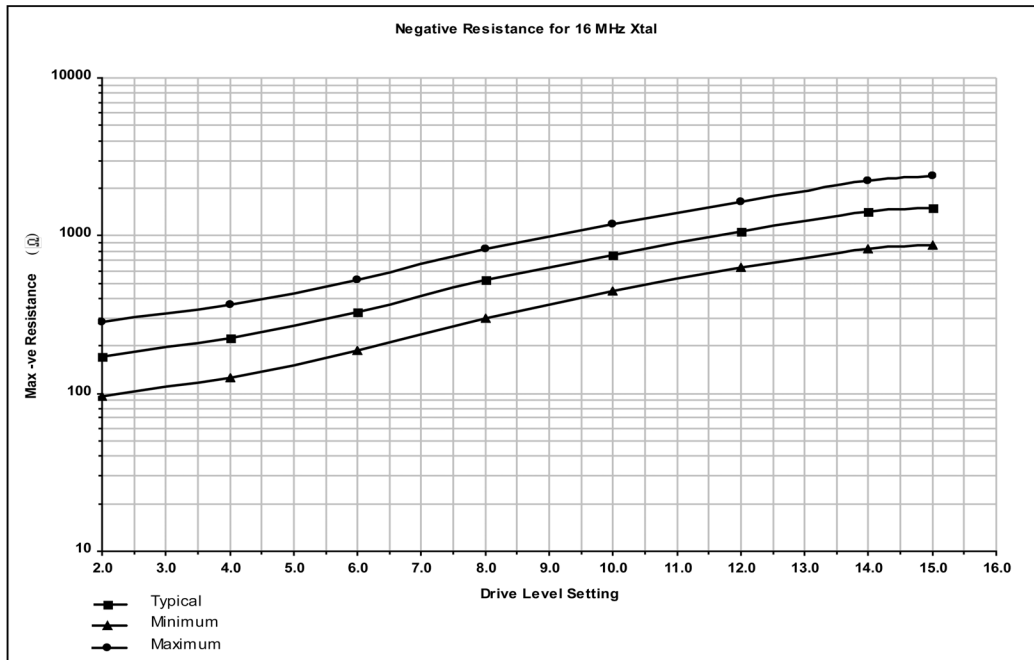

Figure 8.7: Crystal Driver Negative Resistance as a Function of Drive Level Setting

Crystal parameters:

Crystal frequency 16MHz (refer to your software build release note for supported frequencies).

Crystal $C_0 = 0.75\text{pF}$

Circuit parameters:

$C_{\text{trim}} = 8\text{pF}$, maximum value

$C_{t1}, C_{t2} = 5\text{pF}$ (3.9pF plus 1.1 pF stray)

(Crystal total load capacitance 8.5pF)

Note:

This is for a specific crystal and load capacitance.

8.4 UART Interface

This is a standard Universal Asynchronous Receiver Transmitter (UART) interface for communicating with other serial devices.

BlueCore4-Audio Flash UART interface provides a simple mechanism for communicating with other serial devices using the RS232 protocol.⁽¹⁾

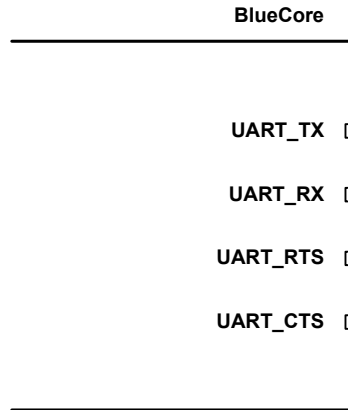

Figure 8.8: Universal Asynchronous Receiver

Four signals are used to implement the UART function, as shown in Figure 8.8. When BlueCore4-Audio Flash is connected to another digital device, UART_RX and UART_TX transfer data between the two devices. The remaining two signals, UART_CTS and UART_RTS, can be used to implement RS232 hardware flow control where both are active low indicators. All UART connections are implemented using CMOS technology and have signalling levels of 0V and VDD_USB.

UART configuration parameters, such as data rate and packet format, are set using BlueCore4-Audio Flash software.

Note:

In order to communicate with the UART at its maximum data rate using a standard PC, an accelerated serial port adapter card is required for the PC.

Parameter		Possible Values
Data Rate	Minimum	1200 bits/s ($\leq 2\%$ Error)
		9600 bits/s ($\leq 1\%$ Error)
	Maximum	3M bit/s ($\leq 1\%$ Error)
Flow Control		RTS/CTS or None
Parity		None, Odd or Even
Number of Stop Bits		1 or 2
Bits per Channel		8

Table 8.5: Possible UART Settings

The UART interface is capable of resetting BlueCore4-Audio Flash upon reception of a break signal. A break is identified by a continuous logic low (0V) on the UART_RX terminal, as shown in Figure 8.9. If t_{BRK} is longer than the value, defined by PSKEY_HOST_IO_UART_RESET_TIMEOUT, (0x1a4), a reset will occur. This feature allows a host to initialise the system to a known state. Also, BlueCore4-Audio Flash can emit a break character that may be used to wake the host.

⁽¹⁾ Uses RS232 protocol, but voltage levels are 0V to VDD_USB (requires external RS232 transceiver chip).

Figure 8.9: Break Signal
Note:

The DFU boot loader must be loaded into the Flash device before the UART or USB interfaces can be used. This initial flash programming can be done via the SPI.

Table 8.6 shows a list of commonly used data rates and their associated values for PSKEY_UART_BAUD_RATE (0x204). There is no requirement to use these standard values. Any data rate within the supported range can be set in the PS Key according to the formula in Equation 8.10.

$$\text{Data Rate} = \frac{\text{PSKEY_UART_BAUDRATE}}{0.004096}$$

Equation 8.10: Data Rate

Data Rate (bits/s)	Persistent Store Value		Error
	Hex	Dec	
1200	0x0005	5	1.73%
2400	0x000a	10	1.73%
4800	0x0014	20	1.73%
9600	0x0027	39	-0.82%
19200	0x004f	79	0.45%
38400	0x009d	157	-0.18%
57600	0x00ec	236	0.03%
76800	0x013b	315	0.14%
115200	0x01d8	472	0.03%
230400	0x03b0	944	0.03%
460800	0x075f	1887	-0.02%
921600	0x0ebf	3775	0.00%
1382400	0x161e	5662	-0.01%
1843200	0x1d7e	7550	0.00%
2764800	0x2c3d	11325	0.00%

Table 8.6: Standard Data Rates

8.4.1 UART Bypass

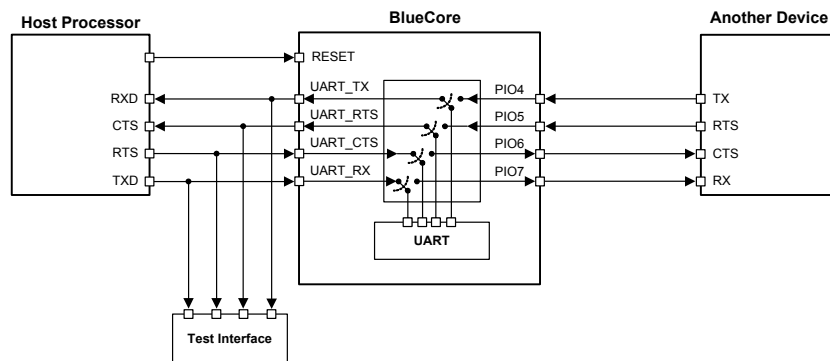

Figure 8.10: UART Bypass Architecture

8.4.2 UART Configuration While RESET is Active

The UART interface for BlueCore4-Audio Flash while the chip is being held in reset is tri-state. This will allow the user to daisy chain devices onto the physical UART bus. The constraint on this method is that any devices connected to this bus must tri-state when BlueCore4-Audio Flash reset is de-asserted and the firmware begins to run.

8.4.3 UART Bypass Mode

Alternatively, for devices that do not tri-state the UART bus, the UART bypass mode on BlueCore4-Audio Flash can be used. The default state of BlueCore4-Audio Flash after reset is de-asserted; this is for the host UART bus to be connected to the BlueCore4-Audio Flash UART, thereby allowing communication to BlueCore4-Audio Flash via the UART. All UART bypass mode connections are implemented using CMOS technology and have signalling levels of 0V and VDD_PADS.⁽¹⁾

In order to apply the UART bypass mode, a BCCMD command will be issued to BlueCore4-Audio Flash. Upon this issue, it will switch the bypass to PIO[7:4] as Figure 8.10 indicates. Once the bypass mode has been invoked, BlueCore4-Audio Flash will enter the Deep Sleep state indefinitely.

In order to re-establish communication with BlueCore4-Audio Flash, the chip must be reset so that the default configuration takes effect.

It is important for the host to ensure a clean Bluetooth disconnection of any active links before the bypass mode is invoked. Therefore, it is not possible to have active Bluetooth links while operating the bypass mode.

8.4.4 Current Consumption in UART Bypass Mode

The current consumption for a device in UART bypass mode is equal to the values quoted for a device in standby mode.

⁽¹⁾ The range of the signalling level for the standard UART described in section 8.4 and the UART bypass may differ between CSR BlueCore devices, as the power supply configurations are chip dependent. For BlueCore4-Audio Flash, the standard UART is supplied by VDD_USB, so has signalling levels of 0V and VDD_USB. Whereas in the UART bypass mode, the signals appear on PIO[4:7] which are supplied by VDD_PADS, therefore the signalling levels are 0V and VDD_PADS.

8.5 USB Interface

This is a full speed (12Mbits/s) Universal Serial Bus (USB) interface for communicating with other compatible digital devices. BlueCore4-Audio Flash acts as a USB peripheral, responding to requests from a master host controller such as a PC.

The USB interface is capable of driving a USB cable directly. No external USB transceiver is required. The device operates as a USB peripheral, responding to requests from a master host controller such as a PC. Both the OHCI and the UHCI standards are supported. The set of USB endpoints implemented can behave as specified in the USB section of the Bluetooth specification v2.0+EDR or alternatively can appear as a set of endpoints appropriate to USB audio devices such as speakers.

As USB is a master/slave oriented system (in common with other USB peripherals), BlueCore4-Audio Flash only supports USB Slave operation.

8.5.1 USB Data Connections

The USB data lines emerge as pins USB_DP and USB_DN. These terminals are connected to the internal USB I/O buffers of the BlueCore4-Audio Flash, therefore, have a low output impedance. To match the connection to the characteristic impedance of the USB cable, resistors must be placed in series with USB_DP/USB_DN and the cable.

8.5.2 USB Pull-Up Resistor

BlueCore4-Audio Flash features an internal USB pull-up resistor. This pulls the USB_DP pin weakly high when BlueCore4-Audio Flash is ready to enumerate. It signals to the PC that it is a full speed (12Mbits/s) USB device.

The USB internal pull-up is implemented as a current source, and is compliant with section 7.1.5 of the USB specification v1.2. The internal pull-up pulls USB_DP high to at least 2.8V when loaded with a 15k Ω \pm 5% pull-down resistor (in the hub/host) when VDD_PADS = 3.1V. This presents a Thevenin resistance to the host of at least 900 Ω . Alternatively, an external 1.5k Ω pull-up resistor can be placed between a PIO line and D+ on the USB cable. The firmware must be alerted to which mode is used by setting PSKEY_USB_PIO_PULLUP appropriately. The default setting uses the internal pull-up resistor.

8.5.3 USB Power Supply

The USB specification dictates that the minimum output high voltage for USB data lines is 2.8V. To safely meet the USB specification, the voltage on the VDD_USB supply terminals must be an absolute minimum of 3.1V. CSR recommends 3.3V for optimal USB signal quality.

8.5.4 Self-Powered Mode

In self-powered mode, the circuit is powered from its own power supply and not from the VBUS (5V) line of the USB cable. It draws only a small leakage current (below 0.5mA) from VBUS on the USB cable. This is the easier mode for which to design, as the design is not limited by the power that can be drawn from the USB hub or root port. However, it requires that VBUS be connected to BlueCore4-Audio Flash via a resistor network (R_{vb1} and R_{vb2}), so BlueCore4-Audio Flash can detect when VBUS is powered up. BlueCore4-Audio Flash will not pull USB_DP high when VBUS is off.

Self-powered USB designs (powered from a battery or PSU) must ensure that a PIO line is allocated for USB pull-up purposes. A 1.5k Ω 5% pull-up resistor between USB_DP and the selected PIO line should be fitted to the design. Failure to fit this resistor may result in the design failing to be USB compliant in self-powered mode. The internal pull-up in BlueCore is only suitable for bus-powered USB devices, e.g., dongles.

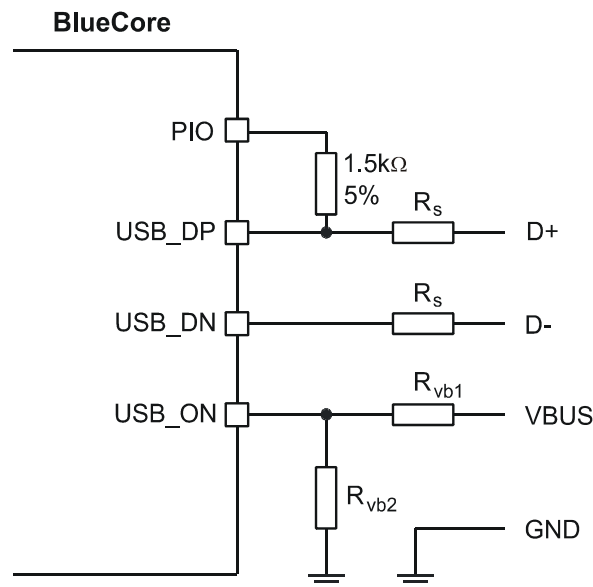

Figure 8.11: USB Connections for Self-Powered Mode

The terminal marked USB_ON can be any free PIO pin. The PIO pin selected must be registered by setting PSKEY_USB_PIO_VBUS to the corresponding pin number.

Note:

USB_ON is shared with BlueCore4-Audio Flash PIO terminals.

Identifier	Value	Function
R_s	27 Ω nominal	Impedance matching to USB cable
R_{vb1}	22k Ω 5%	VBUS ON sense divider
R_{vb2}	47k Ω 5%	VBUS ON sense divider

Table 8.7: USB Interface Component Values

8.5.5 Bus-Powered Mode

In bus-powered mode, the application circuit draws its current from the 5V VBUS supply on the USB cable. BlueCore4-Audio Flash negotiates with the PC during the USB enumeration stage about how much current it is allowed to consume.

For Class 2 Bluetooth applications, CSR recommends that the regulator used to derive 3.3V from VBUS is rated at 100mA average current and should be able to handle peaks of 120mA without foldback or limiting. In bus-powered mode, BlueCore4-Audio Flash requests 100mA during enumeration.

For Class 1 Bluetooth applications, the USB power descriptor should be altered to reflect the amount of power required. This is accomplished by setting `PSKEY_USB_MAX_POWER (0x2c6)`. This is higher than for a Class 2 application due to the extra current drawn by the Transmit RF PA.

When selecting a regulator, be aware that VBUS may go as low as 4.4V. The inrush current (when charging reservoir and supply decoupling capacitors) is limited by the USB specification. See USB Specification v1.1, section 7.2.4.1. Some applications may require soft start circuitry to limit inrush current if more than 10 μ F is present between VBUS and GND.

The 5V VBUS line emerging from a PC is often electrically noisy. As well as regulation down to 3.3V and 1.8V, applications should include careful filtering of the 5V line to attenuate noise that is above the voltage regulator bandwidth. Excessive noise on the 1.8V supply to the analogue supply pins of BlueCore4-Audio Flash will result in reduced receive sensitivity and a distorted RF transmit signal.

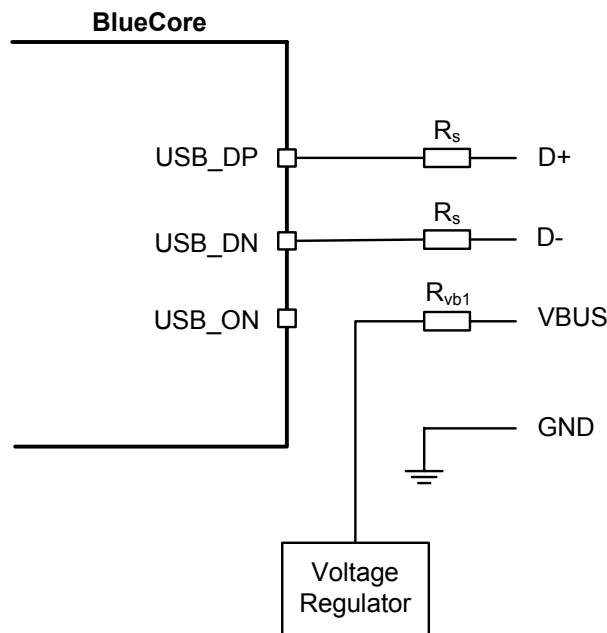

Figure 8.12: USB Connections for Bus-Powered Mode

8.5.6 Suspend Current

All USB devices must permit the USB controller to place them in a USB suspend mode. While in USB Suspend, bus-powered devices must not draw more than 0.5mA from USB VBUS (self-powered devices may draw more than 0.5mA from their own supply). This current draw requirement prevents operation of the radio by bus-powered devices during USB Suspend.

The voltage regulator circuit itself should draw only a small quiescent current (typically less than 100 μ A) to ensure adherence to the suspend current requirement of the USB specification. This is not normally a problem with modern regulators. Ensure that external LEDs and/or amplifiers can be turned off by BlueCore4-Audio Flash. The entire circuit must be able to enter the suspend mode. Refer to separate CSR documentation for more details on USB Suspend.

8.5.7 Detach and Wake_Up Signalling

BlueCore4-Audio Flash can provide out-of-band signalling to a host controller by using the control lines called `USB_DETACH` and `USB_WAKE_UP`. These are outside the USB specification (no wires exist for them inside the USB cable), but can be useful when embedding BlueCore4-Audio Flash into a circuit where no external USB is visible to the user. Both control lines are shared with PIO pins and can be assigned to any PIO pin by setting `PSKEY_USB_PIO_DETACH` and `PSKEY_USB_PIO_WAKEUP` to the selected PIO number.

`USB_DETACH` is an input which, when asserted high, causes BlueCore4-Audio Flash to put `USB_DN` and `USB_DP` in a high impedance state and turns off the pull-up resistor on DP. This detaches the device from the bus and is logically equivalent to unplugging the device. When `USB_DETACH` is taken low, BlueCore4-Audio Flash will connect back to USB and await enumeration by the USB host.

USB_WAKE_UP is an active high output (used only when USB_DETACH is active) to wake up the host and allow USB communication to recommence. It replaces the function of the software USB WAKE_UP message (which runs over the USB cable) and cannot be sent while BlueCore4-Audio Flash is effectively disconnected from the bus.

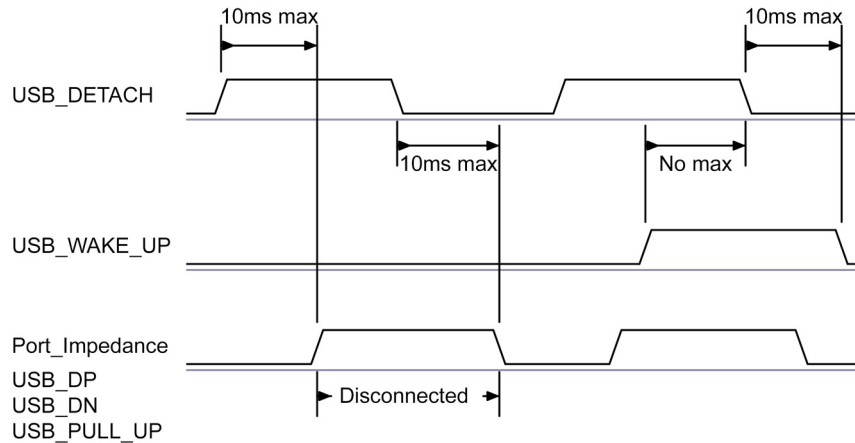

Figure 8.13: USB_DETACH and USB_WAKE_UP Signal

8.5.8 USB Driver

A USB Bluetooth device driver is required to provide a software interface between BlueCore4-Audio Flash and Bluetooth software running on the host computer. Suitable drivers are available from <http://www.csrsupport.com>.

8.5.9 USB 1.1 Compliance

BlueCore4-Audio Flash is qualified to the USB Specification v1.1, details of which are available from <http://www.usb.org>. The specification contains valuable information on aspects such as PCB track impedance, supply inrush current and product labelling.

Although BlueCore4-Audio Flash meets the USB specification, CSR cannot guarantee that an application circuit designed around the chip is USB compliant. The choice of application circuit, component choice and PCB layout all affect USB signal quality and electrical characteristics. The information in this document is intended as a guide and should be read in association with the USB specification, with particular attention being given to Chapter 7. Independent USB qualification must be sought before an application is deemed USB compliant and can bear the USB logo. Such qualification can be obtained from a USB plugfest or from an independent USB test house.

Terminals USB_DP and USB_DN adhere to the USB specification v2.0 (Chapter 7) electrical requirements.

8.5.10 USB 2.0 Compatibility

BlueCore4-Audio Flash is compatible with USB v2.0 host controllers; under these circumstances the two ends agree the mutually acceptable rate of 12Mbits/s according to the USB v2.0 specification.

8.6 Serial Peripheral Interface

BlueCore4-Audio Flash uses 16-bit data and 16-bit address serial peripheral interface, where transactions may occur when the internal processor is running or is stopped. This section details the considerations required when interfacing to BlueCore4-Audio Flash via the four dedicated serial peripheral interface terminals. Data may be written or read one word at a time or the auto increment feature may be used to access blocks.

8.6.1 Instruction Cycle

The BlueCore4-Audio Flash is the slave and receives commands on SPI_MOSI and outputs data on SPI_MISO. Table 8.8 shows the instruction cycle for an SPI transaction.

1	Reset the SPI interface	Hold high for two SPI_CLK cycles
2	Write the command word	Take low and clock in the 8 bit command
3	Write the address	Clock in the 16-bit address word
4	Write or read data words	Clock in or out 16-bit data word(s)
5	Termination	Take high

Table 8.8: Instruction Cycle for an SPI Transaction

With the exception of reset, SPI_CSB must be held low during the transaction. Data on SPI_MOSI is clocked into the BlueCore4-Audio Flash on the rising edge of the clock line SPI_CLK. When reading, BlueCore4-Audio Flash will reply to the master on SPI_MISO with the data changing on the falling edge of the SPI_CLK. The master provides the clock on SPI_CLK. The transaction is terminated by taking SPI_CSB high.

Sending a command word and the address of a register for every time it is to be read or written is a significant overhead, especially when large amounts of data are to be transferred. To overcome this BlueCore4-Audio Flash offers increased data transfer efficiency via an auto increment operation. To invoke auto increment, SPI_CSB is kept low, which auto increments the address, while providing an extra 16 clock cycles for each extra word to be written or read.

8.6.2 Writing to the Device

To write to BlueCore4-Audio Flash, the 8-bit write command (00000010) is sent first (C[7:0]) followed by a 16-bit address (A[15:0]). The next 16-bits (D[15:0]) clocked in on SPI_MOSI are written to the location set by the address (A). Thereafter for each subsequent 16-bits clocked in, the address (A) is incremented and the data written to consecutive locations until the transaction terminates when SPI_CS_B is taken high.

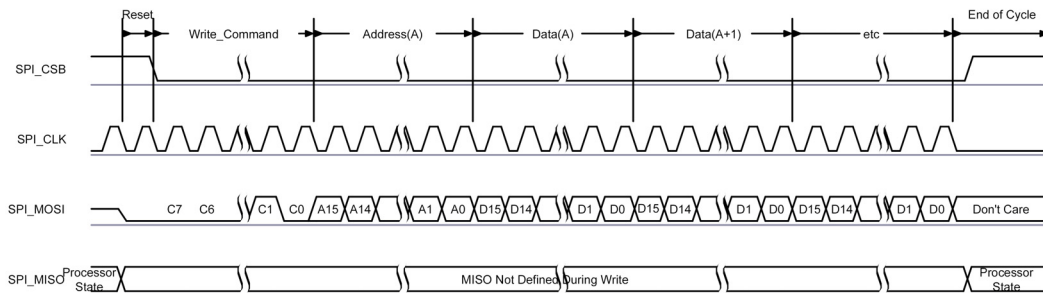

Figure 8.14: SPI Write Operation

8.6.3 Reading from the Device

Reading from BlueCore4-Audio Flash is similar to writing to it. An 8-bit read command (00000011) is sent first (C[7:0]), followed by the address of the location to be read (A[15:0]). BlueCore4-Audio Flash then outputs on SPI_MISO a check word during T[15:0] followed by the 16-bit contents of the addressed location during bits D[15:0].

The check word is composed of {command, address [15:8]}. The check word may be used to confirm a read operation to a memory location. This overcomes the problems encountered with typical serial peripheral interface slaves, whereby it is impossible to determine whether the data returned by a read operation is valid data or the result of the slave device not responding.

If SPI_CS_B is kept low, data from consecutive locations is read out on SPI_MISO for each subsequent 16 clocks, until the transaction terminates when SPI_CS_B is taken high.

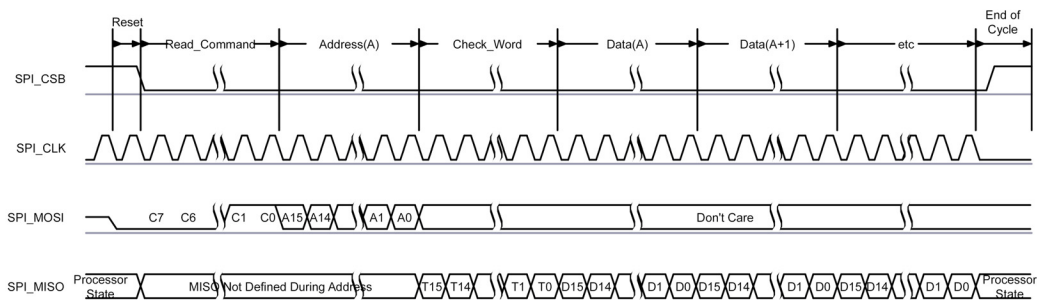

Figure 8.15: SPI Read Operation

8.6.4 Multi-Slave Operation

BlueCore4-Audio Flash should not be connected in a multi-slave arrangement by simple parallel connection of slave MISO lines. When BlueCore4-Audio Flash is deselected (SPI_CS_B = 1), the SPI_MISO line does not float. Instead, BlueCore4-Audio Flash outputs 0 if the processor is running or 1 if it is stopped.

8.7 Mono Audio CODEC

The BlueCore4-Audio Flash audio CODEC is compatible with the direct speaker drive and microphone input using a minimum number of external components. It is primarily intended for voice applications and it is fully operational from a single 1.8V power supply. A fully differential architecture has been implemented for optimal power supply rejection and low noise performance. The digital format is 15-bit/sample linear PCM with a data rate of 8kHz.

The CODEC has an input stage containing a microphone amplifier, variable gain amplifier and a $\Sigma\Delta$ ADC. Its output stage contains a DAC, low-pass filter and output amplifier. The CODEC functional diagram is shown in below.

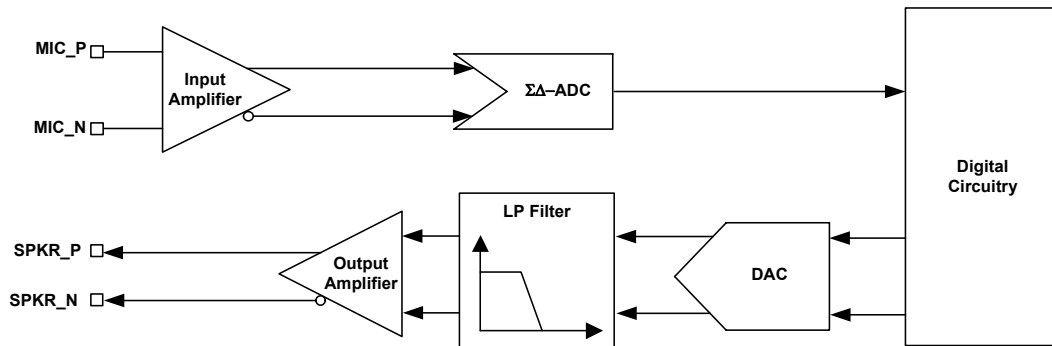

Figure 8.16: BlueCore4-Audio Flash CODEC Diagram

8.7.1 Input Stage

A low noise variable gain amplifier amplifies the signal difference between inputs MIC_N and MIC_P. The input may be from either a microphone or line input. The amplified signal is then digitised by a second order $\Sigma\Delta$ ADC. The high frequency single bit output from the ADC is converted to 15-bit 8kHz linear PCM data.

The gain is programmable via a PS Key and has a 42dB range with 3dB resolution. At maximum gain the full scale input level is 3mV rms. A bias network is required for operation with a microphone whereas the line input may be simply AC coupled. The following sections explain each of these modes. Single-ended signals are supported by BlueCore4-Audio Flash: a single-ended signal may be driven into either MIC_N or MIC_P with the undriven input coupled to ground by a capacitor.

The signal to noise ratio is better than 60dB and distortion is less than -75dB.

8.7.2 Microphone Input

The BlueCore4-Audio Flash audio CODEC has been designed for use with microphones that have sensitivities between -60 and -40dBV. The sensitivity of -60dBV is equivalent to a microphone output of 1 μ A when presented with an input level of 94dB SPL and loaded with 1k Ω . The microphone should be biased as shown in Figure 8.17.

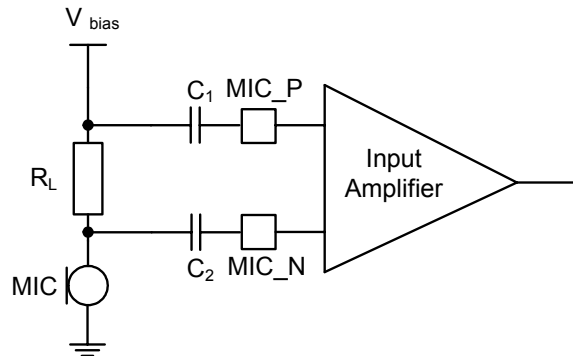

Figure 8.17: BlueCore4-Audio Flash Microphone Biasing

The input impedance at MIC_N and MIC_P is typically 20k Ω . C1 and C2 should be 47nF. R_L sets the microphone load impedance and is normally between 1 and 2k Ω . V_{bias} should be chosen to suit the microphone and have sufficient low noise. It may be obtained by filtering the output of a PIO line.

8.7.3 Line Input

If the input gain is set to less than 21dB BlueCore4-Audio Flash automatically selects line input mode. In this mode the input impedance at MIC_N and MIC_P is increased to 130k Ω typical. At the minimum gain setting the maximum input signal level is 380mV rms. Figure 8.18 and Figure 8.19 show two circuits for line input operation and show connections for either differential or single-ended inputs.

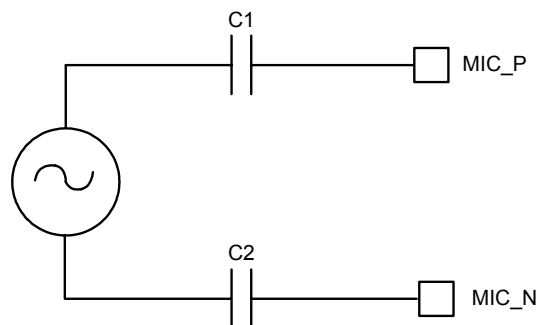

Figure 8.18: Differential Microphone Input

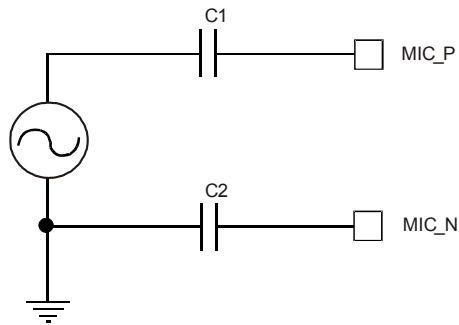

Figure 8.19: Single-ended Microphone Input

Note:

C1 and C2 should be 15nF.

8.7.4 Output Stage

The digital data is converted to an analogue value by a DAC, then it is filtered prior to amplification by the output amplifier and it is available as a differential signal between SPKR_P and SPKR_N. The output amplifier is capable of driving a speaker directly if its impedance is greater than 8Ω . The amplifier is stable with capacitive loads up to 500pF.

The gain is programmable with a range of 21dB and a resolution of 3dB. Maximum output level is typically 700 mV rms for high impedance loads, or 20mA rms for low impedance loads. The signal to noise is better than 70dB and the distortion is less than -75dB.

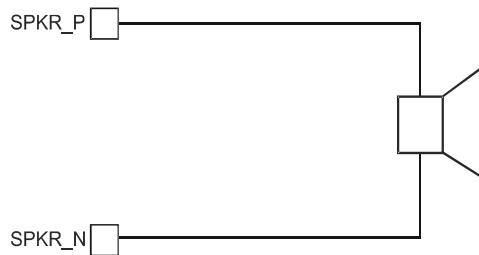

Figure 8.20: Speaker Output

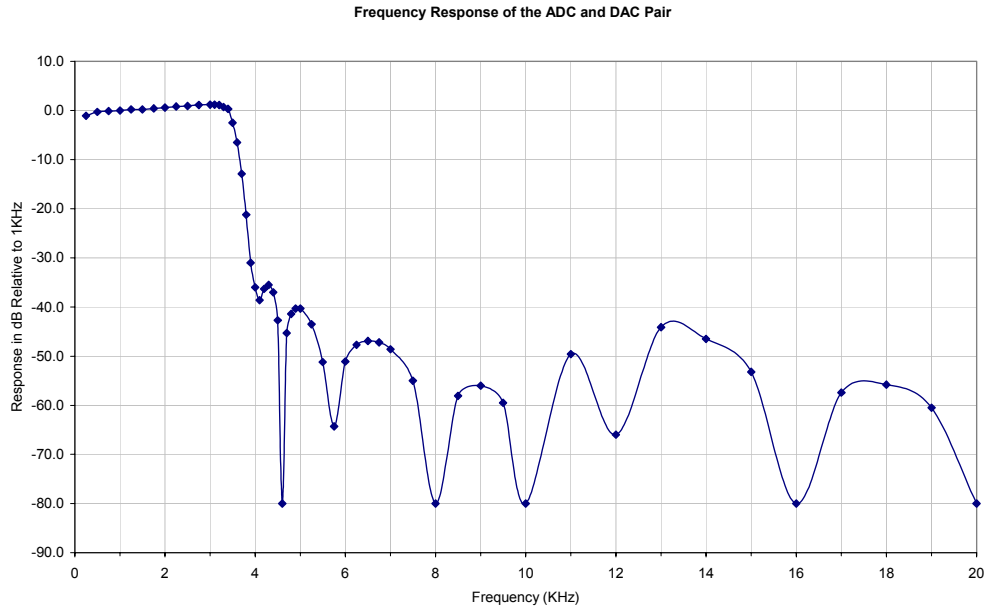

Figure 8.21: Frequency Response of the ADC and DAC Pair

8.7.5 Single-Ended Speaker Termination

Certain applications require that a single-ended speaker termination scheme is used in place of the standard differential output. BlueCore4-Audio Flash allows the unused SPKR_N output to be disabled to reduce static power consumption, or alternatively, to be used to buffer the internal reference voltage that is used by the SPKR_P drive. It is also possible to externally decouple the voltage reference via an AIO.

8.7.6 Bass Cut (Wind Noise Reduction)

Digital enhancements have been made to the BlueCore4-Audio Flash mono CODEC to reduce wind noise. The wind noise filter rejects low frequencies present in the ADC signal. This is achieved by combining an analogue reconstruction filter and a digital filter located at the output of the ADC processing chain (see Figure 8.23).

The digital wind noise filter has been designed to compensate for the frequency response of a single-pole analogue high-pass filter with a 3dB cut-off frequency at 800Hz. The analogue high-pass filter characteristic is provided by the audio input resistance in conjunction with external AC coupling capacitors. A simulation of the frequency response for bass cut (wind noise reduction) digital enhancement is shown in Figure 8.22.

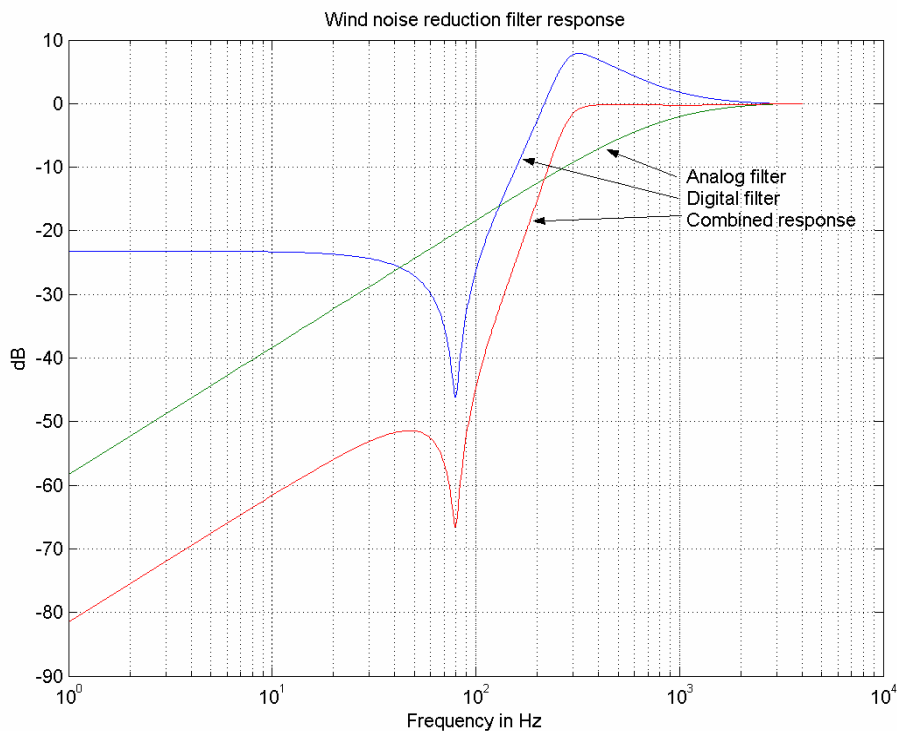

Figure 8.22: Simulated Wind Noise Reduction Filter Response

8.7.7 Side Tone

In some applications it is necessary to implement side tone. This involves feeding an attenuated version of the microphone signal to the earpiece. The BlueCore4-Audio Flash mono CODEC now incorporates the means to do this (see Figure 8.23).

The control bits in the IO_KCODEC_CONFIG register are shown in Figure 8.9

8.7.8 Audio CODEC Outline and Applicable Gains

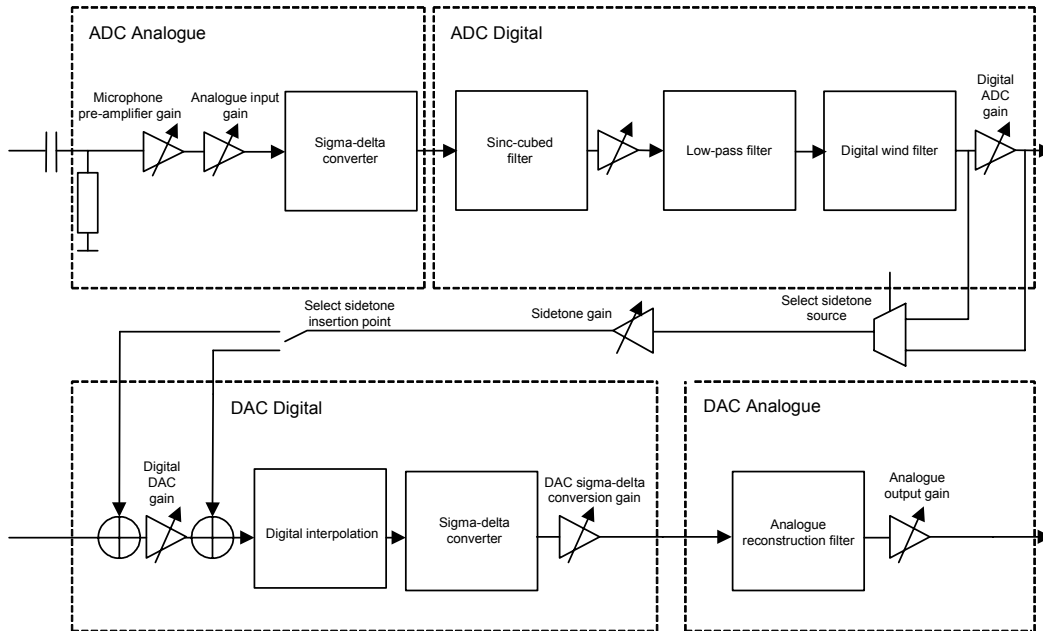

Figure 8.23: Audio CODEC Outline and Applicable Gains

8.7.9 Firmware Interface

Bit	Read/Write	Reset Value	Signal Name	Comment
[12]	W	Sync b0	CODEC_DITHER_SMALL_EN	
[11]	W	Sync b0	CODEC_ADC_LF_REJECT_HI_EN	Reserved. Set to Zero
[10]	W	Sync b0	CODEC_ADC_LF_REJECT_EN	
[9]	W	Sync b0	CODEC_SCALE_EN	
[8]	W	Sync b0	CODEC_NOTCH_EN	
[7]	W	Sync b0	CODEC_DITHER_EN	
[6]	W	Sync b0	CODEC_SCALE_FINE_EN	
[5:4]	W	Sync b00	CODEC_SIDETONE_ROUTE[1:0]	[1] selects the side tone addition to the DAC output before (when one) or after (when zero) applying the DAC digital gain [0] selects the side tone source to be the ADC output signal before (when zero) or after (when one) the ADC gain
[3:1]	W	Sync b000	CODEC_SIDETONE_GAIN	Side tone gain control
[0]	W	Sync b0	CODEC_SIDETONE_EN	Enable the side tone hardware

Table 8.9: IO_KCODEC_CONFIG Control Register

Note:

In BlueCore4-Audio Flash all configuration bits are contained in a single register dedicated to the audio CODEC.

Gain Name	PS Key Control Bits	Recommended Usage	Settings
Microphone pre-amplifier gain	CODEC_IN_GAIN[3]	Use to select between line input and microphone input	0 = 0 dB, 1 = 21 dB
Analogue input gain	CODEC_IN_GAIN[2:0]	Use to control the audio input gain	0 = 0dB, 1 = 3dB, 2 = 6dB, 3 = 9dB, 4 = 12dB, 5 = 15dB, 6 = 18 dB, 7 = 21 dB
Sinc-cubed filter gain	CODEC_IN_GAIN[8]	Set to zero	0 = 0 dB, 1 = -6 dB
Digital ADC gain	CODEC_IN_GAIN[7:4]	Use to control the audio input gain, if the analogue ADC gain is exhausted	0 = 0 dB, 1 = 3.5 dB, 2 = 6 dB, 3 = 9.5 dB, 4 = 12 dB, 5 = 15.5 dB, 6 = 18 dB, 7 = 21.5 dB, 8 = -24 dB, 9 = -20.5 dB, 10 = -18 dB, 11 = -14.5 dB, 12 = -12 dB, 13 = -8.5 dB, 14 = -6 dB, 15 = -2.5 dB
Digital DAC gain	CODEC_OUT_GAIN[7:4]	Use to control the audio output gain, if the analogue DAC gain is exhausted	Same as for the digital ADC gain
DAC sigma-delta conversion gain	CODEC_OUT_GAIN[9:8]	Set to 3	0 = 0dB, 1 = 2 dB, 2 = 3.5 dB, 3 = 4.9 dB
Analogue output gain	CODEC_OUT_GAIN[2:0]	Use to control the audio output gain. Do not use setting 7.	Same as for the analogue ADC gain

Table 8.10: Recommended Settings for Audio CODEC

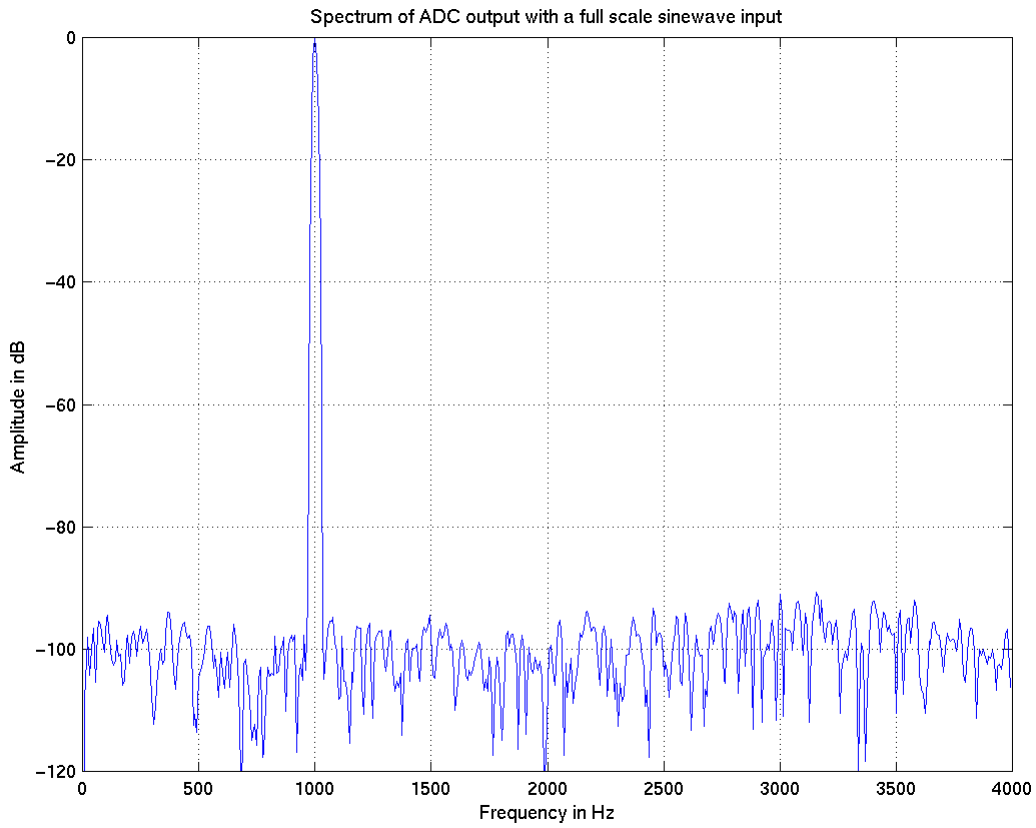

Figure 8.24: Spectrum of Analogue and Digital ADC Output with a Full Scale Sine Wave Input

Note:

(300mV RMS) sine into analogue mic amp. Output from digital ADC (extracted from BlueCore4-Audio Flash voice buffer).

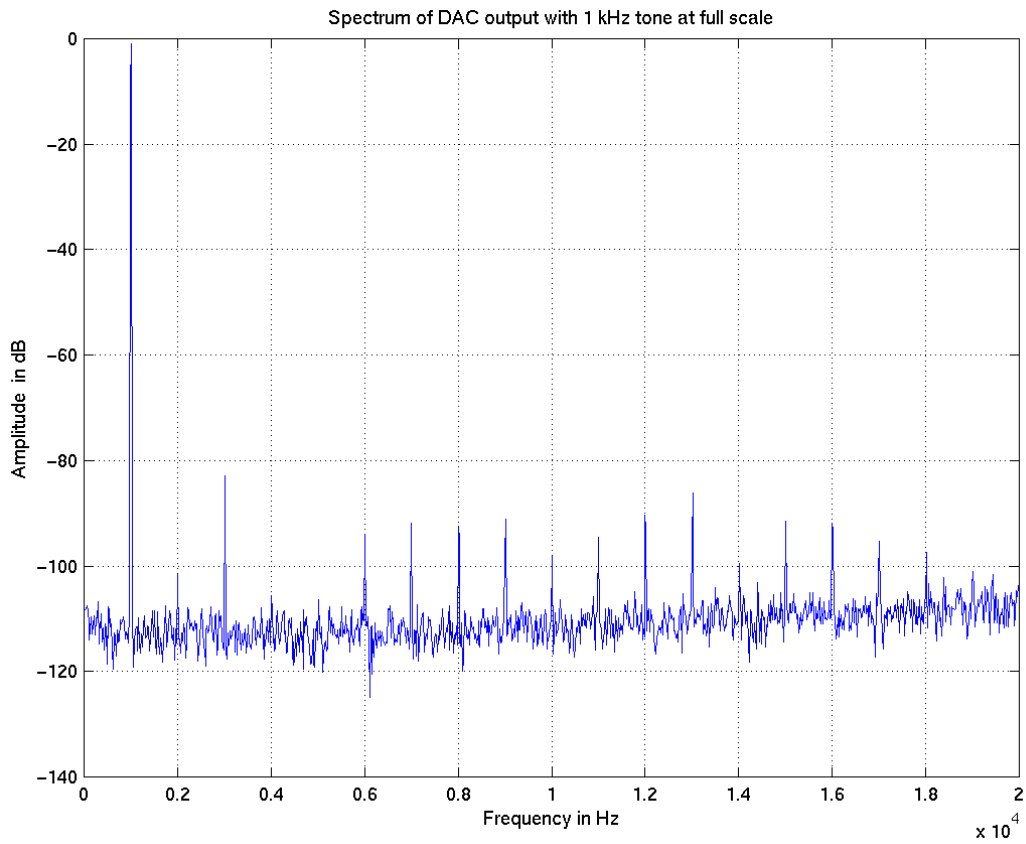

Figure 8.25: Spectrum of DAC Output with 1kHz Full Scale Tone

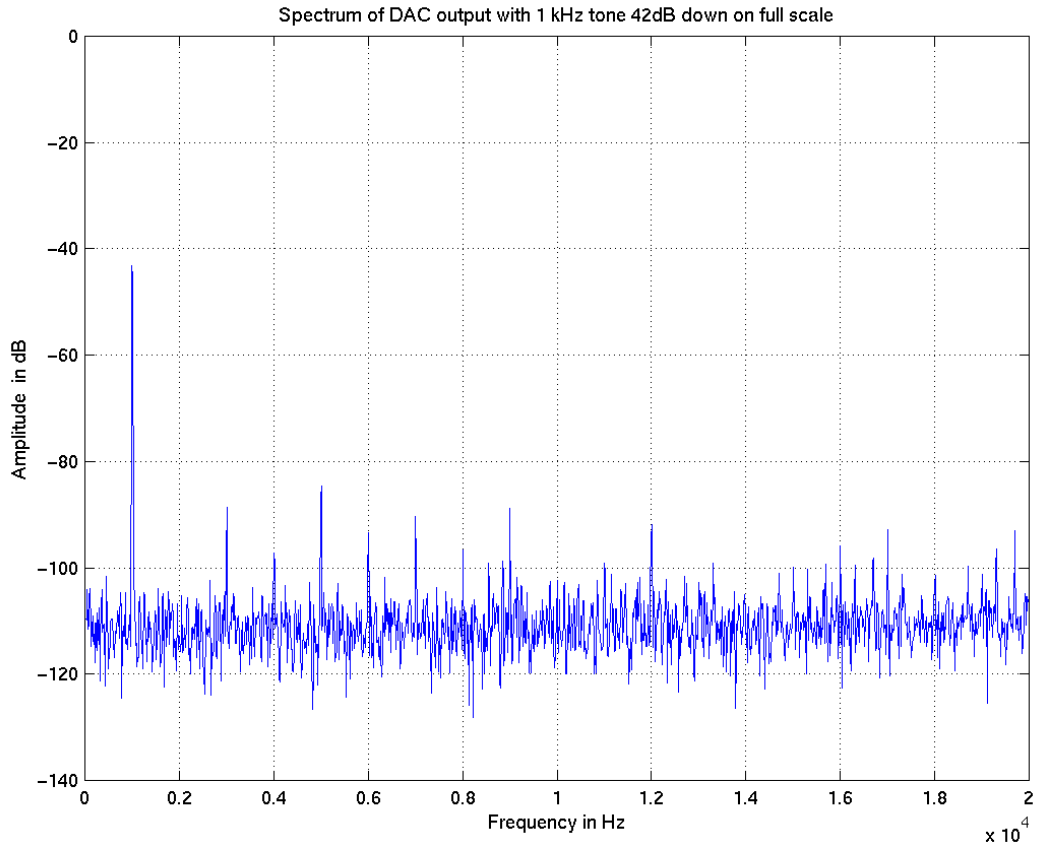

Figure 8.26: Spectrum of DAC Output with 1kHz Tone at -42dB Relative to Full Scale

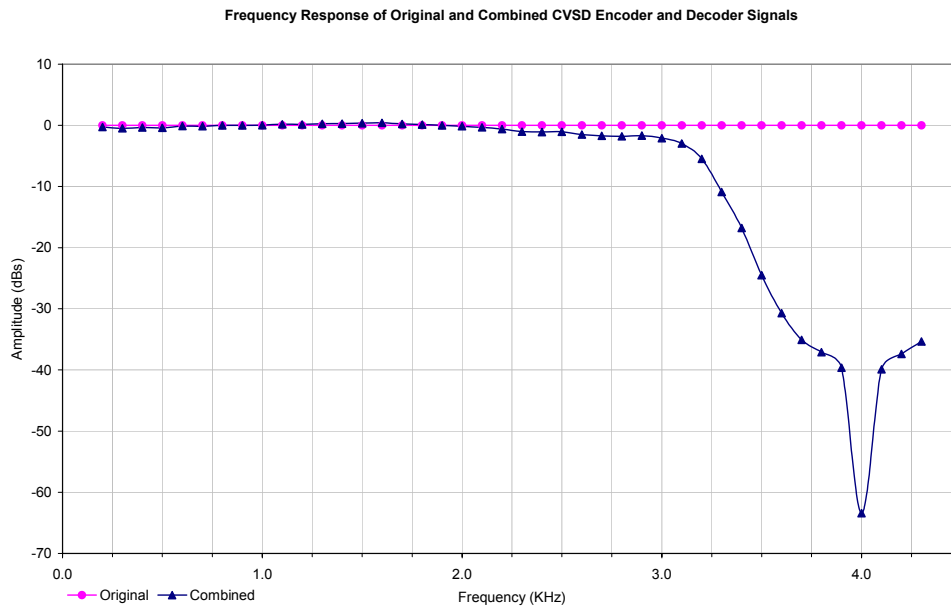

Figure 8.27: Response of CVSD Interpolation/Decimation Filter

8.8 PCM CODEC Interface

Pulse Code Modulation (PCM) is a standard method used to digitise audio (particularly voice) for transmission over digital communication channels. Through its PCM interface, BlueCore4-Audio Flash has hardware support for continual transmission and reception of PCM data, thus reducing processor overhead for wireless headset applications. BlueCore4-Audio Flash offers a bi-directional digital audio interface that routes directly into the baseband layer of the on-chip firmware. It does not pass through the HCI protocol layer.

Hardware on BlueCore4-Audio Flash allows the data to be sent to and received from a SCO connection. ⁽¹⁾

Up to three SCO connections can be supported by the PCM interface at any one time.

BlueCore4-Audio Flash can operate as the PCM interface master generating an output clock of 128, 256 or 512kHz. When configured as PCM interface slave, it can operate with an input clock up to 2048kHz. BlueCore4-Audio Flash is compatible with a variety of clock formats, including Long Frame Sync, Short Frame Sync and GCI timing environments.

It supports 13-bit or 16-bit linear, 8-bit μ -law or A-law companded sample formats at 8ksamples/s and can receive and transmit on any selection of three of the first four slots following PCM_SYNC. The PCM configuration options are enabled by setting PSKEY_PCM_CONFIG32 (0x1b3).

BlueCore4-Audio Flash interfaces directly to PCM audio devices including the following:

- Qualcomm MSM 3000 series and MSM 5000 series CDMA baseband devices
- OKI MSM7705 four channel A-law and μ -law CODEC
- Motorola MC145481 8-bit A-law and μ -law CODEC
- Motorola MC145483 13-bit linear CODEC
- STW 5093 and 5094 14-bit linear CODECs
- BlueCore4-Audio Flash is also compatible with the Motorola SSI interface

8.8.1 PCM Interface Master/Slave

When configured as the master of the PCM interface, BlueCore4-Audio Flash generates PCM_CLK and PCM_SYNC.

⁽¹⁾ Subject to firmware support. Contact CSR for current status.

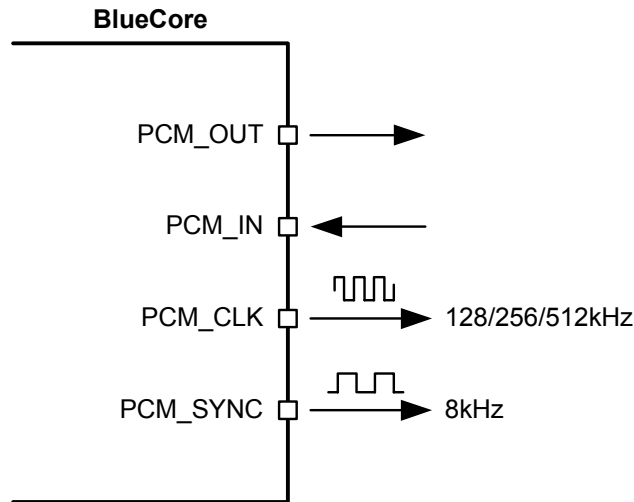

Figure 8.28: BlueCore4-Audio Flash as PCM Interface Master

When configured as the Slave of the PCM interface, BlueCore4-Audio Flash accepts PCM_CLK rates up to 2048kHz.

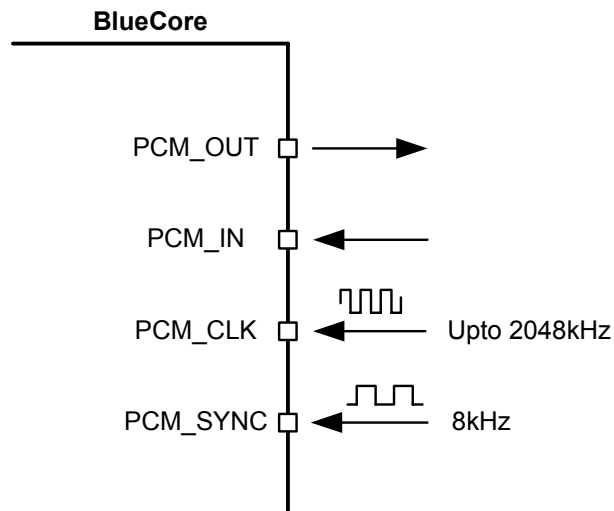

Figure 8.29: BlueCore4-Audio Flash as PCM Interface Slave

8.8.2 Long Frame Sync

Long Frame Sync is the name given to a clocking format that controls the transfer of PCM data words or samples. In Long Frame Sync, the rising edge of PCM_SYNC indicates the start of the PCM word. When BlueCore4-Audio Flash is configured as PCM master, generating PCM_SYNC and PCM_CLK, then PCM_SYNC is 8-bits long. When BlueCore4-Audio Flash is configured as PCM Slave, PCM_SYNC may be from two consecutive falling edges of PCM_CLK to half the PCM_SYNC rate, i.e., 62.5µs long.

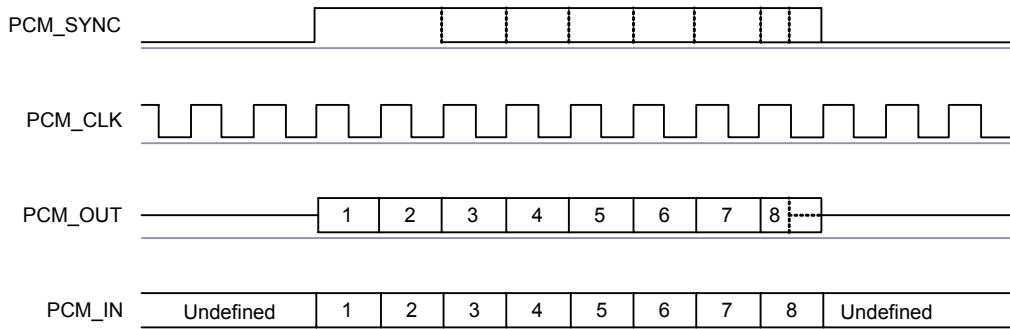

Figure 8.30: Long Frame Sync (Shown with 8-bit Companded Sample)

BlueCore4-Audio Flash samples PCM_IN on the falling edge of PCM_CLK and transmits PCM_OUT on the rising edge. PCM_OUT may be configured to be high impedance on the falling edge of PCM_CLK in the LSB position or on the rising edge.

8.8.3 Short Frame Sync

In Short Frame Sync, the falling edge of PCM_SYNC indicates the start of the PCM word. PCM_SYNC is always one clock cycle long.

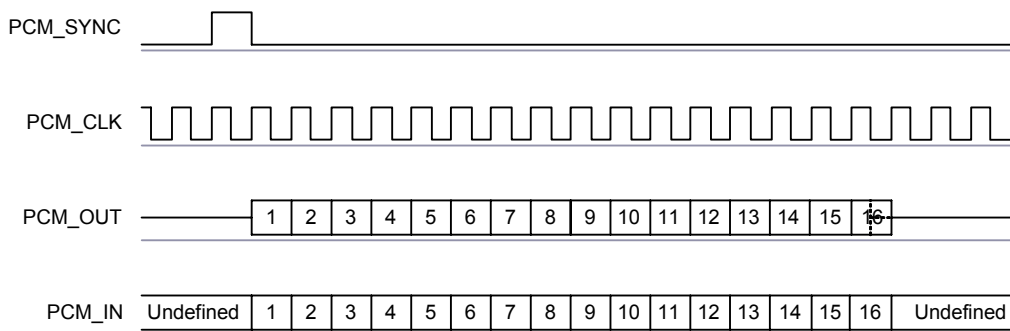

Figure 8.31: Short Frame Sync (Shown with 16-bit Sample)

As with Long Frame Sync, BlueCore4-Audio Flash samples PCM_IN on the falling edge of PCM_CLK and transmits PCM_OUT on the rising edge. PCM_OUT may be configured to be high impedance on the falling edge of PCM_CLK in the LSB position or on the rising edge.

8.8.4 Multi-slot Operation

More than one SCO connection over the PCM interface is supported using multiple slots. Up to three SCO connections can be carried over any of the first four slots.

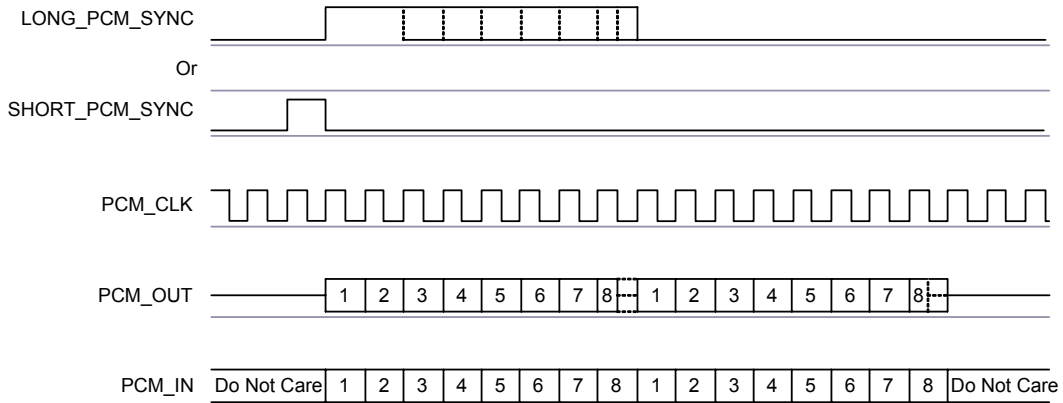

Figure 8.32: Multi-slot Operation with Two Slots and 8-bit Companded Samples

8.8.5 GCI Interface

BlueCore4-Audio Flash is compatible with the General Circuit Interface (GCI), a standard synchronous 2B+D ISDN timing interface. The two 64kbits/s B channels can be accessed when this mode is configured.

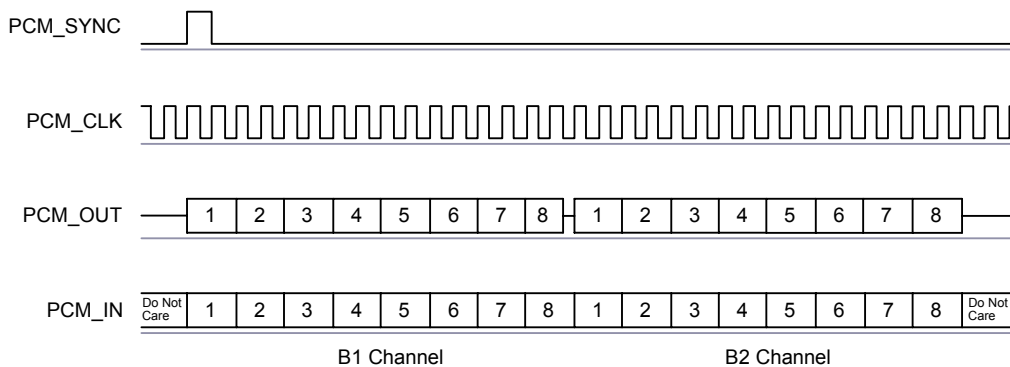

Figure 8.33: GCI Interface

The start of frame is indicated by the rising edge of PCM_SYNC and runs at 8kHz. With BlueCore4-Audio Flash in Slave mode, the frequency of PCM_CLK can be up to 4.096MHz.

8.8.6 Slots and Sample Formats

BlueCore4-Audio Flash can receive and transmit on any selection of the first four slots following each sync pulse. Slot durations can be either 8 or 16 clock cycles. Durations of 8 clock cycles may only be used with 8-bit sample formats. Durations of 16 clocks may be used with 8-bit, 13-bit or 16-bit sample formats.

BlueCore4-Audio Flash supports 13-bit linear, 16-bit linear and 8-bit μ -law or A-law sample formats. The sample rate is 8ksamples/s. The bit order may be little or big endian. When 16-bit slots are used, the 3 or 8 unused bits in each slot may be filled with sign extension, padded with zeros or a programmable 3-bit audio attenuation compatible with some Motorola CODECs.

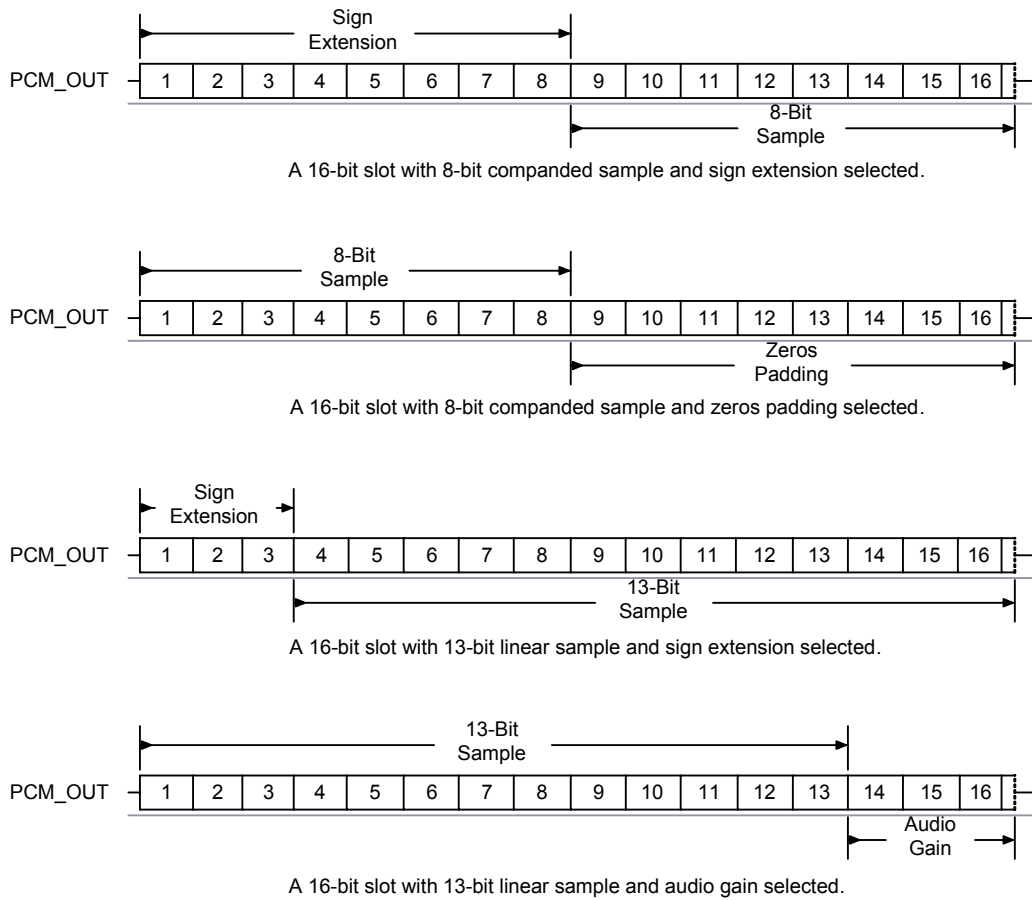

Figure 8.34: 16-Bit Slot Length and Sample Formats

8.8.7 Additional Features

BlueCore4-Audio Flash has a mute facility that forces PCM_OUT to be 0. In master mode, PCM_SYNC may also be forced to 0 while keeping PCM_CLK running which some CODECs use to control power down.

8.8.8 PCM Timing Information

Symbol	Parameter		Min	Typ	Max	Unit
f_{mclk}	PCM_CLK frequency	4MHz DDS generation. Selection of frequency is programmable. See Table 8.13.	-	128 256 512	-	kHz
		48MHz DDS generation. Selection of frequency is programmable. See Table 8.14 and PCM_CLK and PCM_SYNC Generation on page 84.	2.9		-	kHz
-	PCM_SYNC frequency		-	8		kHz
$t_{mclkh}^{(a)}$	PCM_CLK high	4MHz DDS generation	980	-	-	ns
$t_{mclkl}^{(a)}$	PCM_CLK low	4MHz DDS generation	730	-		ns
-	PCM_CLK jitter	48MHz DDS generation			21	ns pk-pk
$t_{dmclksynch}$	Delay time from PCM_CLK high to PCM_SYNC high		-	-	20	ns
$t_{dmclkpout}$	Delay time from PCM_CLK high to valid PCM_OUT		-	-	20	ns
$t_{dmclksyncl}$	Delay time from PCM_CLK low to PCM_SYNC low (Long Frame Sync only)		-	-	20	ns
$t_{dmclksyncl}$	Delay time from PCM_CLK high to PCM_SYNC low		-	-	20	ns
$t_{dmclkpoutz}$	Delay time from PCM_CLK low to PCM_OUT high impedance		-	-	20	ns
$t_{dmclhpoutz}$	Delay time from PCM_CLK high to PCM_OUT high impedance		-	-	20	ns
$t_{supinclk}$	Set-up time for PCM_IN valid to PCM_CLK low		30	-	-	ns
$t_{hpinclk}$	Hold time for PCM_CLK low to PCM_IN invalid		10	-	-	ns

Table 8.11: PCM Master Timing

(a) Assumes normal system clock operation. Figures will vary during low power modes, when system clock speeds are reduced.

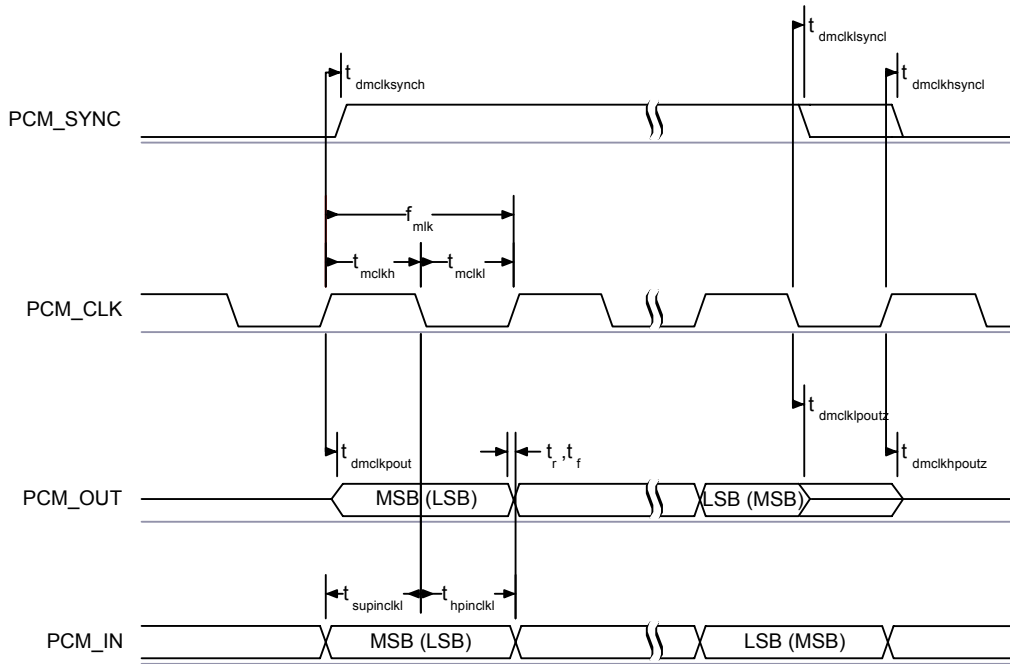
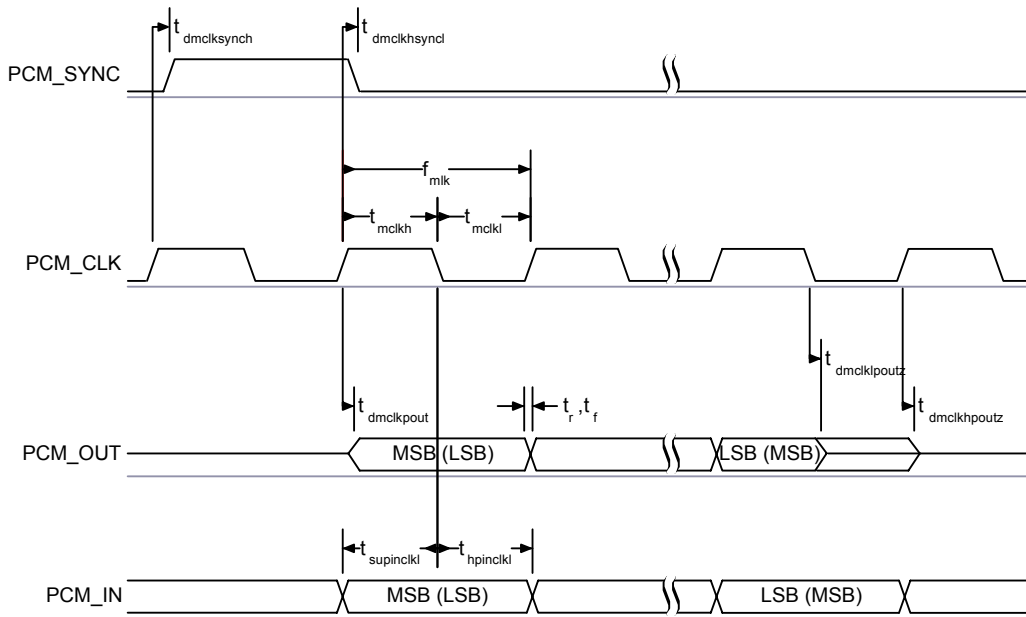
Figure 8.35: PCM Master Timing Long Frame Sync

Figure 8.36: PCM Master Timing Short Frame Sync

Symbol	Parameter	Min	Typ	Max	Unit
f_{sclk}	PCM clock frequency (Slave mode: input)	64	-	2048	kHz
f_{sclk}	PCM clock frequency (GCI mode)	128	-	4096	kHz
t_{sckl}	PCM_CLK low time	200	-	-	ns
t_{sckh}	PCM_CLK high time	200	-	-	ns
$t_{hscklsynch}$	Hold time from PCM_CLK low to PCM_SYNC high	30	-	-	ns
$t_{suscklsynch}$	Set-up time for PCM_SYNC high to PCM_CLK low	30	-	-	ns
t_{dpout}	Delay time from PCM_SYNC or PCM_CLK whichever is later, to valid PCM_OUT data (Long Frame Sync only)	-	-	20	ns
$t_{dsckhpout}$	Delay time from CLK high to PCM_OUT valid data	-	-	20	ns </td
t_{dpoutz}	Delay time from PCM_SYNC or PCM_CLK low, whichever is later, to PCM_OUT data line high impedance	-	-	20	ns
$t_{supinsckl}$	Set-up time for PCM_IN valid to CLK low	30	-	-	ns
$t_{hpinsckl}$	Hold time for PCM_CLK low to PCM_IN invalid	30	-	-	ns

Table 8.12: PCM Slave Timing

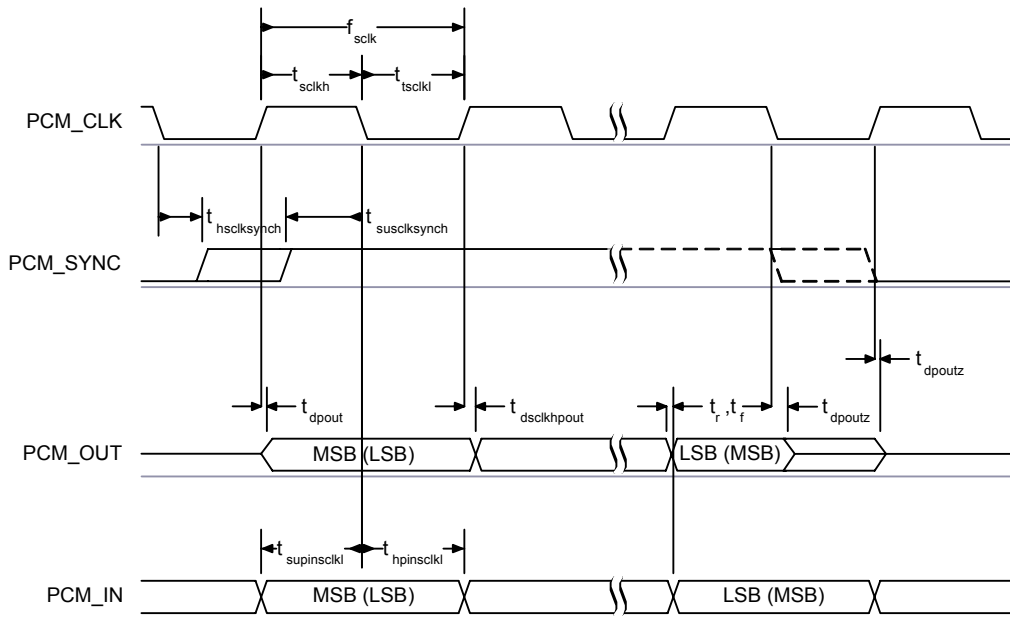

Figure 8.37: PCM Slave Timing Long Frame Sync

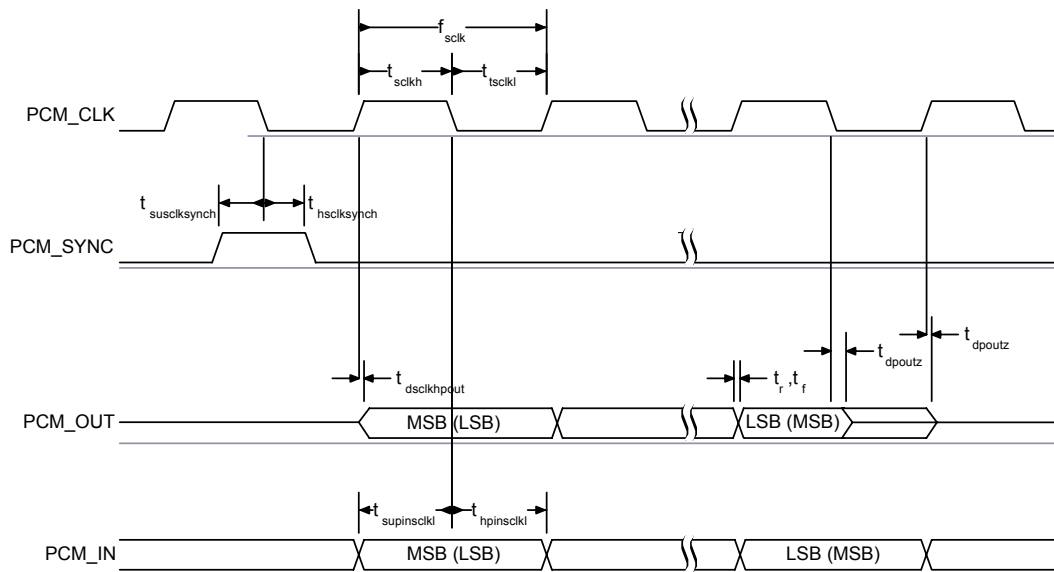

Figure 8.38: PCM Slave Timing Short Frame Sync

PCM_CLK and PCM_SYNC Generation

BlueCore4-Audio Flash has two methods of generating PCM_CLK and PCM_SYNC in master mode. The first is generating these signals by Direct Digital Synthesis (DDS) from BlueCore4-Audio Flash internal 4MHz clock (which is used in BlueCore2-External). Using this mode limits PCM_CLK to 128, 256 or 512kHz and PCM_SYNC to 8kHz. The second is generating PCM_CLK and PCM_SYNC by DDS from an internal 48MHz clock (which allows a greater range of frequencies to be generated with low jitter but consumes more power). This second method is selected by setting bit 48M_PCM_CLK_GEN_EN in PSKEY_PCM_CONFIG32. When in this mode and with long frame sync, the length of PCM_SYNC can be either 8 or 16 cycles of PCM_CLK, determined by LONG_LENGTH_SYNC_EN in PSKEY_PCM_CONFIG32.

The Equation 8.11 describes PCM_CLK frequency when being generated using the internal 48MHz clock:

$$f = \frac{\text{CNT_RATE}}{\text{CNT_LIMIT}} \times 24\text{MHz}$$

Equation 8.11: PCM_CLK Frequency When Being Generated Using the Internal 48MHz Clock

The frequency of PCM_SYNC relative to PCM_CLK can be set using Equation 8.12:

$$f = \frac{\text{PCM_CLK}}{\text{SYNC_LIMIT} \times 8}$$

Equation 8.12: PCM_SYNC Frequency Relative to PCM_CLK

CNT_RATE, CNT_LIMIT and SYNC_LIMIT are set using PSKEY_PCM_LOW_JITTER_CONFIG. As an example, to generate PCM_CLK at 512kHz with PCM_SYNC at 8kHz, set PSKEY_PCM_LOW_JITTER_CONFIG to 0x08080177.

8.8.9 PCM Configuration

The PCM configuration is set using two PS Keys, PSKEY_PCM_CONFIG32 detailed in Table 8.13 and PSKEY_PCM_LOW_JITTER_CONFIG in Table 8.14. The default for PSKEY_PCM_CONFIG32 is 0x00800000, i.e., first slot following sync is active, 13-bit linear voice format, long frame sync and interface master generating 256kHz PCM_CLK from 4MHz internal clock with no tri-state of PCM_OUT.

Name	Bit Position	Description
-	0	Set to 0
SLAVE_MODE_EN	1	0 = master mode with internal generation of PCM_CLK and PCM_SYNC. 1 = slave mode requiring externally generated PCM_CLK and PCM_SYNC.
SHORT_SYNC_EN	2	0 = long frame sync (rising edge indicates start of frame). 1 = short frame sync (falling edge indicates start of frame).
-	3	Set to 0.
SIGN_EXTEND_EN	4	0 = padding of 8 or 13-bit voice sample into a 16-bit slot by inserting extra LSBs. When padding is selected with 13-bit voice sample, the 3 padding bits are the audio gain setting; with 8-bit sample the 8 padding bits are zeroes. 1 = sign-extension.
LSB_FIRST_EN	5	0 = MSB first of transmit and receive voice samples. 1 = LSB first of transmit and receive voice samples.
TX_TRISTATE_EN	6	0 = drive PCM_OUT continuously. 1 = tri-state PCM_OUT immediately after falling edge of PCM_CLK in the last bit of an active slot, assuming the next slot is not active.
TX_TRISTATE_RISING_EDGE_EN	7	0 = tri-state PCM_OUT immediately after falling edge of PCM_CLK in last bit of an active slot, assuming the next slot is also not active. 1 = tri-state PCM_OUT after rising edge of PCM_CLK.
SYNC_SUPPRESS_EN	8	0 = enable PCM_SYNC output when master. 1 = suppress PCM_SYNC whilst keeping PCM_CLK running. Some CODECS utilise this to enter a low power state.
GCI_MODE_EN	9	1 = enable GCI mode
MUTE_EN	10	1 = force PCM_OUT to 0
48M_PCM_CLK_GEN_EN	11	0 = set PCM_CLK and PCM_SYNC generation via DDS from internal 4MHz clock. 1 = set PCM_CLK and PCM_SYNC generation via DDS from internal 48MHz clock.
LONG_LENGTH_SYNC_EN	12	0 = set PCM_SYNC length to 8 PCM_CLK cycles. 1 = set length to 16 PCM_CLK cycles. Only applies for long frame sync and with 48M_PCM_CLK_GEN_EN set to 1.
-	[20:16]	Set to 0b00000
MASTER_CLK_RATE	[22:21]	Selects 128 (0b01), 256 (0b00), 512 (0b10) kHz PCM_CLK frequency when master and 48M_PCM_CLK_GEN_EN (bit 11) is low.
ACTIVE_SLOT	[26:23]	Default is 0001. Ignored by firmware.

Name	Bit Position	Description
SAMPLE_FORMAT	[28:27]	Selects between 13 (0b00), 16 (0b01), 8 (0b10) bit sample with 16 cycle slot duration or 8 (0b11) bit sample with 8 cycle slot duration.

Table 8.13: PSKEY_PCM_CONFIG32 Description

Name	Bit Position	Description
CNT_LIMIT	[12:0]	Sets PCM_CLK counter limit
CNT_RATE	[23:16]	Sets PCM_CLK count rate
SYNC_LIMIT	[31:24]	Sets PCM_SYNC division relative to PCM_CLK

Table 8.14: PSKEY_PCM_LOW_JITTER_CONFIG Description

8.9 I/O Parallel Ports

Fifteen lines of programmable bi-directional input/outputs (I/O) are provided. PIO[11:8] and PIO[3:0] are powered from VDD_PIO. PIO[7:4] are powered from VDD_PADS. AIO [2:0] are powered from VDD_USB.

PIO lines can be configured through software to have either weak or strong pull-ups or pull-downs. All PIO lines are configured as inputs with weak pull-downs at reset.

PIO[0] and PIO[1] are normally dedicated to RXEN and TXEN respectively, but they are available for general use.

Any of the PIO lines can be configured as interrupt request lines or as wake-up lines from sleep modes. PIO[6] or PIO[2] can be configured as a request line for an external clock source. This is useful when the clock to BlueCore4-Audio Flash is provided from a system application specific integrated circuit (ASIC). Using PSKEY_CLOCK_REQUEST_ENABLE (0x246), this terminal can be configured to be low when BlueCore4-Audio Flash is in Deep Sleep and high when a clock is required. The clock must be supplied within 4ms of the rising edge of PIO[6] or PIO[2] to avoid losing timing accuracy in certain Bluetooth operating modes.

BlueCore4-Audio Flash has three general purpose analogue interface pins, AIO[0], AIO[1] and AIO[2] also known as the extended PIO lines. These are used to access internal circuitry and control signals. One pin is allocated to decoupling for the on-chip band gap reference voltage; the other two may be configured to provide additional functionality.

Auxiliary functions available via these pins include an 8-bit ADC and an 8-bit DAC. Typically the ADC is used for battery voltage measurement. Signals selectable at these pins include the band gap reference voltage and a variety of clock signals: 48, 24, 16, 8MHz and the XTAL clock frequency. When used with analogue signals, the voltage range is constrained by the analogue supply voltage (1.8V). When configured to drive out digital level signals (e.g., clocks), the output voltage level is determined by VDD_USB (1.8V).

8.9.1 PIO Defaults

CSR cannot guarantee that these terminal functions remain the same. Refer to the software release note for the implementation of these PIO lines, as they are firmware build-specific.

8.10 I²C Interface

PIO[8:6] can be used to form a master I²C interface. The interface is formed using software to drive these lines. Therefore, it is suited only to relatively slow functions such as driving a dot matrix liquid crystal display (LCD), keyboard scanner or EEPROM.

Any three PIOs can be used as a master I²C interface by configuring the hardware bit serialiser with suitable firmware. The strong pull-ups in the PIO pads eliminate the need for external pull-up resistors.

Notes:

PIO lines need to be pulled-up through 2.2k Ω resistors.

PIO[7:6] dual functions, UART bypass and EEPROM support, therefore, devices using an EEPROM cannot support UART bypass mode.

For connection to EEPROMs, refer to CSR documentation on I²C EEPROMs for use with BlueCore. This provides information on the type of devices currently supported.

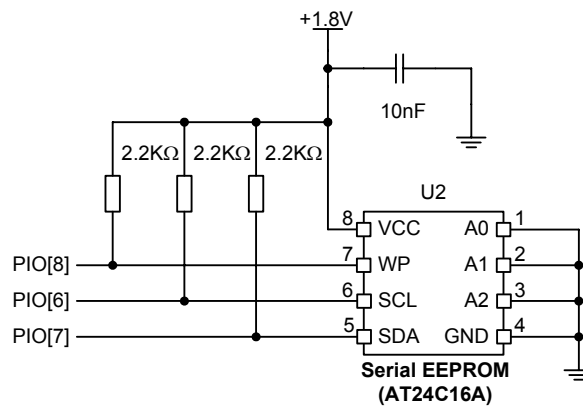

Figure 8.39: Example EEPROM Connection

8.11 TCXO Enable OR Function

An OR function exists for clock enable signals from a host controller and BlueCore4-Audio Flash where either device can turn on the clock without having to wake up the other device. PIO[3] can be used as the host clock enables input and PIO[2] can be used as the OR output with the TCXO enable signal from BlueCore4-Audio Flash.

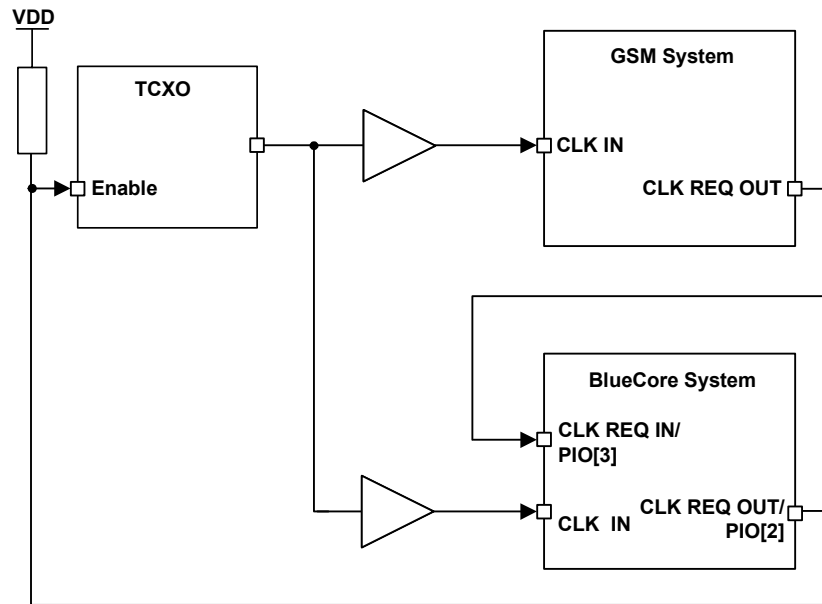

Figure 8.40: Example TCXO Enable OR Function

On reset and up to the time the PIO has been configured, PIO[2] will be tri-state. Therefore, the developer must ensure that the circuitry connected to this pin is pulled via a 470k Ω resistor to the appropriate power rail. This ensures that the TCXO is oscillating at start up.

8.12 RESETB

BlueCore4-Audio Flash may be reset from several sources: RESETB pin, power on reset, a UART break character or via a software configured watchdog timer.

The RESETB pin is an active low reset and is internally filtered using the internal low frequency clock oscillator. A reset will be performed between 1.5 and 4.0ms following RESETB being active. It is recommended that RESETB be applied for a period greater than 5ms.

The power on reset occurs when the VDD_CORE supply falls below typically 1.5V and is released when VDD_CORE rises above typically 1.6V. At reset the digital I/O pins are set to inputs for bi-directional pins and outputs are tri-state. The PIOs have weak pull-downs. Following a reset, BlueCore4-Audio Flash assumes the maximum XTAL_IN frequency, which ensures that the internal clocks run at a safe (low) frequency until BlueCore4-Audio Flash is configured for the actual XTAL_IN frequency. If no clock is present at XTAL_IN, the oscillator in BlueCore4-Audio Flash free runs, again at a safe frequency.

8.12.1 Pin States on Reset

Pin Name	State
PIO[10:0]	Input with weak pull-down
PCM_OUT	Tri-stated with weak pull-down
PCM_IN	Input with weak pull-down
PCM_SYNC	Input with weak pull-down
PCM_CLK	Input with weak pull-down
UART_TX	Output tri-stated with weak pull-up
UART_RX	Input with weak pull-down
UART_RTS	Output tri-stated with weak pull-up
UART_CTS	Input with weak pull-down
USB_DP	Input with weak pull-down
USB_DN	Input with weak pull-down
SPI_CSB	Input with weak pull-up
SPI_CLK	Input with weak pull-down
SPI_MOSI	Input with weak pull-down
SPI_MISO	Output tri-stated with weak pull-down
AIO[2:0]	Output tri-stated with weak pull-down
RESETB	Input with weak pull-up
TEST_EN	Input with strong pull-down
AUX_DAC	High impedance
RX_IN	High impedance
XTAL_IN	High impedance, 250kΩ to XTAL_OUT
XTAL_OUT	High impedance, 250kΩ to XTAL_IN

Table 8.15: Pin States of BlueCore4-Audio Flash on Reset

8.12.2 Status after Reset

The chip status after a reset is as follows:

- Warm Reset: Data rate and RAM data remain available
- Cold Reset⁽¹⁾: Data rate and RAM data not available

(1) A Cold Reset is either Power cycle, system reset (firmware fault code) or Reset signal. See .

8.13 Power Supply

8.13.1 Power Regulators

BlueCore4-Audio Flash contains two 1.8V regulators, either of which may be used to power the 1.8V supplies of this device. The device pin VREG_ENABLE is used to enable and disable both of these regulators.

8.13.2 Supply Domains and Sequencing

The 1.8V supplies are VDD_ANA, VDD_VCO, VDD_RADIO and VDD_CORE. It is recommended that the 1.8V supplies are all powered at the same time. The order of powering the 1.8V supplies relative to the other I/O supplies (VDD_PIO, VDD_PADS, VDD_USB and VDD_MEM) is not important, however if the I/O supplies are powered before the 1.8V supplies all digital IO will have a weak pull-down irrespective of the reset state.

VDD_ANA, VDD_VCO, and VDD_RADIO should be connected directly to the 1.8V supply; a simple RC filter is recommended for VDD_CORE to reduce transients put back onto the power supply rails.

The I/O supplies may be connected together or independently to supplies at an appropriate voltage. They should be simply decoupled.

8.13.3 External Voltage Source

If the 1.8V rails of BlueCore4-Audio Flash are supplied from an external voltage source, it is recommended that VDD_VCO, VDD_RADIO, and VDD_ANA, should have less than 10mV rms noise levels between 0 to 10MHz.

Single tone frequencies are also to be avoided. The transient response of any regulator used should be 20µs or less. It is essential that the power rail recovers quickly at the start of a packet, where the power consumption will jump to high levels (see average current consumption section).

8.13.4 Switch-mode Regulator

The on-chip switch-mode 1.8V regulator can be used to power the 1.8V supplies. The required external filter circuit should consist of a low resistance 33µH series inductor (between the LX terminal and the 1.8V supply), followed by a low ESR 4.7µF shunt capacitor (between the 1.8V supply and ground). For optimum efficiency the 33µH inductor must have low resistance. To optimise reliability and enable temperature derating, it must also be able to support at least 150mA.

It is recommended that the series resistance of tracks between the BAT_P and BAT_N terminals, the filter components and the external voltage source are minimised to maintain high efficiency power conversion and low supply ripple. The regulator may be enabled by the VREG_ENABLE pin, by the device firmware, or by the internal battery charger. The regulator is switched into a low power pulse skipping mode automatically when the device enters Deep-Sleep mode. When this regulator is not used the terminals BAT_P and LX must be grounded or left unconnected.

8.13.5 Linear Regulator

The on-chip 1.8V linear regulator may also be used to power the 1.8V dependent supplies. It is recommended that a smoothing circuit be used, consisting of an output regulator connected to ground via a 2.2Ω resistor and a series connected 2.2µF low ESR capacitor.

The regulator may be enabled by the VREG_ENABLE pin or by the device firmware. The regulator switches into a low power mode automatically when the device enters Deep-Sleep mode. When this regulator is not used the terminals VREG_IN and VREG_OUT must be grounded or left unconnected.

8.13.6 VREG_ENABLE Pin

The regulator enable pin, VREG_ENABLE can be used to enable and disable the BlueCore4-Audio Flash device if one of the on-chip regulators is being used. The pin is active high and has a weak pull down.

When the pin is pulled high the active regulator is enabled, allowing the device to boot-up. The firmware is then able to latch the regulator on and the VREG_ENABLE pin may be released.

8.13.7 Battery Charger

The battery charger is a constant current/constant voltage charger circuit and is suitable for Lithium Ion/Polymer batteries only. It must be used in conjunction with the switch-mode regulator as the two circuits share a connection with the battery terminal, BAT_P.

The constant current provided by the charger may be set between 25mA and 100mA (typical) allowing different capacity batteries to be charged at their optimum rate. The required current setting is stored in external PROM memory and read by the battery charger during the first boot-up sequence. The charger circuit also requires a float voltage calibration setting which must be measured for each device during production test. This should be stored in external PROM memory, and will be read by the battery charger during the boot-up sequence.

Whenever the charger is powered the switch-mode regulator is enabled automatically. Internal interfaces are provided to allow firmware to monitor the precise battery voltage and the status of the battery charger. The firmware may also disable the charger, for example, if temperature limits for safe charging are exceeded.

By default, an LED connected to the terminal LED[0] will illuminate at full intensity when a battery is being charged. This behaviour may be overridden by the firmware if required.

When the charger supply is not connected to V_CHG the terminal must be left open.

Important Note:

Protection Module

Lithium Ion/Polymer batteries are capable of delivering high currents of several amperes when short-circuited. This can damage connecting wires and Printed Circuit Board (pcb) components. More seriously, pressure can build up in the cell envelope, causing it to explode and injure the user.

CSR strongly suggests that Lithium Ion/Polymer batteries incorporate an integral protection module. This is typically a small Integrated Circuit (IC) and Field Effect Transistor (FET) interposed between the battery body and its connecting wires. The protection module limits the short circuit current. Good modules will also prevent over-charge and over-discharge, which can also cause damage to the battery.

Additional Precautions

CSR also suggests that the following additional precautions are observed:

- The direct current (dc) inlet socket used on the appliance should be of a proprietary design, preventing users from attaching the charger or supply connector for another appliance (e.g., a mobile phone or laptop computer). The use of popular 2.1mm and 2.5mm DC jack sockets must be avoided for this reason.
- Include a voltage limiting circuit (clamp) on the charger inlet. Remember that this circuit could be exposed to voltages as high as 30V (of either polarity) if a laptop computer power supply has been connected. Include a small fuse in series with the DC inlet, but prior to the clamp.
- Never bring the Lithium Ion/Polymer battery connections directly to charging pins on the outside of the appliance casing, where they could be short-circuited by keys in the user's pocket, for example.

Temperature Extremes

Some Lithium Ion/Polymer cells can be damaged by charging at temperature extremes (e.g., below 0°C or above 50°C). Consult the battery manufacture for guidance.

For more information, see the CSR document Lithium Ion/Polymer Battery Safety Information Note.

8.13.8 LED Drivers

BlueCore4-Audio Flash includes two 4.2V tolerant pads dedicated to driving LED indicators. Both pads may be controlled by firmware, while LED[0] can also be set by the battery charger. The intensity of the LEDs may be adjusted by firmware.

The terminals are low output impedance open-drain outputs, so the LED must be connected in series with a current limiting resistor between the battery terminal or positive supply and the pad.

9 Application Schematic

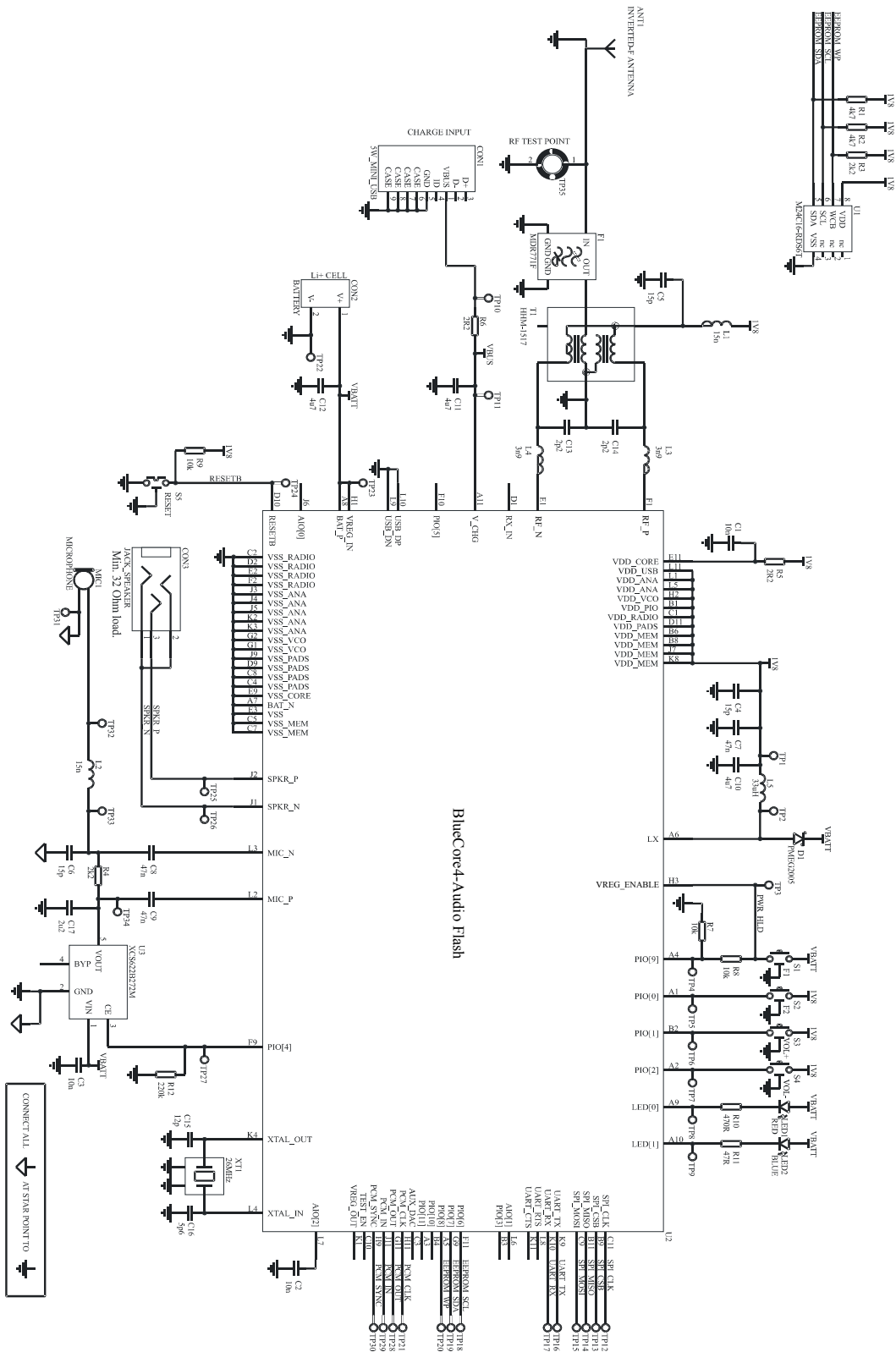
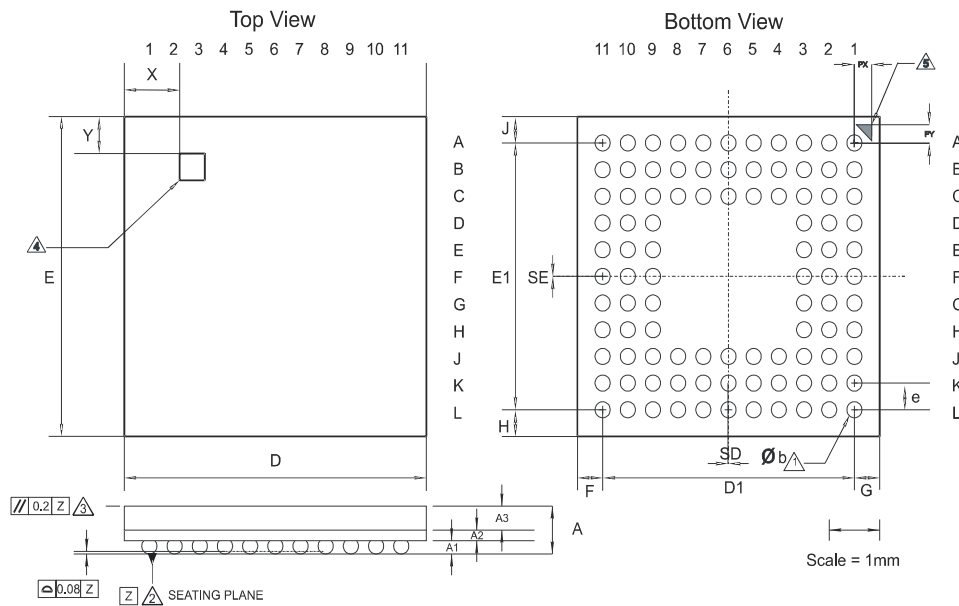

Figure 9.1: Application Circuit for Radio Characteristics Specification

10 Package Dimensions



Description	96-Ball Thin Fine-Pitch Ball Grid Array (TFBGA)			
Size	8 x 8 x 1.2mm			
Pitch	0.65mm			
Package Ball Land	Solder mask defined. Solder mask aperture 275µm Ø			
Dimension	Minimum	Typical	Maximum	Notes
A			1.2	① Dimension b is measured at the maximum solder ball diameter parallel to datum plane Z
A1	0.16	0.21	0.26	
A2		0.21		② Datum Z is defined by the spherical crowns of the solder balls
A3		0.7		
b	0.27	0.32	0.37	③ Parallelism measurement shall exclude any effect of mark on top surface of package
D	7.90	8.00	8.10	
E	7.90	8.00	8.10	④ Top-side polarity mark. The dimensions of the square polarity mark are 0.75 x 0.75mm.
e		0.65		
D1		6.50		⑤ Bottom-side polarity mark. The dimensions of the triangular polarity mark are 0.4 x 0.4mm.
E1		6.50		
F	0.70	0.75	0.80	
G	0.70	0.75	0.80	
H	0.70	0.75	0.80	
J	0.70	0.75	0.80	
PX		0.55		
PY		0.55		
SD		0		
SE		0		
X		1.35		
Y		0.85		
JEDEC	MO-195			
Unit	mm			

Figure 10.1: 8 x 8 x 1.2mm TFBGA 96-Ball Package

11 PCB Design and Assembly Considerations

11.1 8 x 8mm TFBGA 96-Ball Package

This section lists recommendations to achieve maximum board-level reliability of the 8 x 8mm TFBGA 96-ball package:

- Non solder mask defined (NSMD) lands (that is, lands smaller than the solder mask aperture) are preferred because of the greater accuracy of the metal definition process compared to the solder mask process. With solder mask defined pads, the overlap of the solder mask on the land creates a step in the solder at the land interface, which can cause stress concentration and act as a point for crack initiation.
- Ideally, via-in-pad technology should be used to achieve truly NSMD lands. Where this is not possible, a maximum of one trace connected to each land is preferred and this trace should be as thin as possible – taking into consideration its current carrying and the radio frequency (RF) requirements.
- 35 μ m thick (1oz) copper lands are recommended rather than 17 μ m thick (0.5oz). This results in a greater standoff which has been proven to provide greater reliability during thermal cycling.
- Land diameter should be the same as that on the package to achieve optimum reliability.
- Solder paste is preferred to flux during the assembly process because this adds to the final volume of solder in the joint, increasing its reliability.
- Where a nickel gold plating finish is used, the gold thickness should be kept below 0.5 μ m to prevent brittle gold/tin intermetallics forming in the solder.

12 RoHS Statement with a List of Banned Materials

12.1 RoHS Statement

BlueCore4-Audio Flash where explicitly stated in this Data Sheet meets the requirements of Directive 2002/95/EC of the European Parliament and of the Council on the Restriction of Hazardous Substance (RoHS).

12.1.1 List of Banned Materials

The following banned substances are not present in BlueCore4-Audio Flash which is compliant with RoHS:

- Cadmium
- Lead
- Mercury
- Hexavalent chromium
- PBB (Polybrominated Bi-Phenyl)
- PBDE (Polybrominated Diphenyl Ether)

In addition, BlueCore4-Audio Flash is free from the following substances:

- PVC (Polyvinyl Chloride)

13 Ordering Information

13.1 BlueCore4-Audio Flash

Interface Version	Package			Order Number
	Type	Size	Shipment Method	
UART and USB	96-Ball TFBGA (Pb free)	8 x 8 x 1.2mm	Tape and reel	BC41C671A-IPK-E4

Minimum Order Quantity

2kpcs taped and reeled

To contact a CSR representative, email sales@csr.com or go to www.csr.com/contacts.htm

14 Document References

Document	Reference
<i>Specification of the Bluetooth System</i>	v2.0 + EDR, 04 November 2004
<i>Universal Serial Bus Specification</i>	v2.0, 27 April 2000
<i>Selection of I²C EEPROMS for Use with BlueCore</i>	bcore-an008Pb, 30 September 2003
<i>Lithium Ion/Polymer Battery Safety Information Note</i>	bcore-an-057P, 25 November 2004
<i>EDR RF Test Specification v2.0.E.2</i>	v2.0.E.20, D07r22, 16 March 2004
<i>RF Prototyping Specification for Enhanced Data Rate IP</i>	v.90, r29, 2004

15 Terms and Definitions

ACL	Asynchronous Connection-Less, a Bluetooth data packet type
ADC	Analogue to Digital Converter
AGC	Automatic Gain Control
A-law	Audio encoding standard
API	Application Programming Interface
ASIC	Application Specific Integrated Circuit
BCSP	BlueCore™ Serial Protocol
BER	Bit Error Rate. Used to measure the quality of a link
BIST	Built-In Self-Test
BlueCore™	Group term for CSR's range of Bluetooth chips
Bluetooth™	Set of technologies providing audio and data transfer over short-range radio connections
BMC	Burst Mode Controller
CMOS	Complementary Metal Oxide Semiconductor
CODEC	Coder Decoder
CQDDR	Channel Quality Driven Data Rate
CSB	Chip Select (Active Low)
CSR	Cambridge Silicon Radio
CTS	Clear to Send
CVSD	Continuous Variable Slope Delta Modulation
DAC	Digital to Analogue Converter
dBm	Decibels relative to 1mW
DC	Direct Current
DEVM	Differential Error Vector Magnitude
DFU	Device Firmware Upgrade
DSP	Digital Signal Processor
EDR	Enhanced Data Rate
eSCO	Extended Synchronous Connection-Oriented. Voice oriented Bluetooth packet
ESR	Equivalent Series Resistance
Flash	Flash memory
FSK	Frequency Shift Keying
GSM	Global System for Mobile communications
HCI	Host Controller Interface
HID	Human Interface Device
IF	Intermediate Frequency
IQ Modulation	In-Phase and Quadrature Modulation
ISDN	Integrated Services Digital Network
ISM	Industrial, Scientific and Medical

ksamples/s	KiloSamples Per Second
L2CAP	Logical Link Control and Adaptation Protocol (protocol layer)
LC	Link Controller
LCD	Liquid Crystal Display
LED	Light Emitting Diode
LMP	Link Manager Protocol
LNA	Low Noise Amplifier
LSB	Least-Significant Bit
MCU	MicroController Unit
μ-law	Audio Encoding Standard
MMU	Memory Management Unit
MISO	Master In Serial Out
OHCI	Open Host Controller Interface
PA	Power Amplifier
PCM	Pulse Code Modulation. Refers to digital voice data
Persistent Store	Storage of BlueCore's configuration values in non-volatile memory
PID	Proportional plus Integral plus Derivative controller
PIO	Parallel Input Output
PLL	Phase Lock Loop
ppm	parts per million
PS Key	Persistent Store Key
RAM	Random Access Memory
RF	Radio Frequency
RFCOMM	Protocol layer providing serial port emulation over L2CAP
RISC	Reduced Instruction Set Computer
rms	root mean squared
RoHS	The Restriction of Hazardous Substances in Electrical and Electronic Equipment Directive (2002/95/EC)
RSSI	Receive Signal Strength Indication
RTS	Ready To Send
RX	Receive or Receiver
SCO	Synchronous Connection-Oriented. Voice oriented Bluetooth packet
SDK	Software Development Kit
SDP	Service Discovery Protocol
SIG	Special Interest Group
SPI	Serial Peripheral Interface
SSI	Synchronous Serial Interface
TBD	To Be Defined
TCXO	Temperature Compensated crystal Oscillator
TX	Transmit or Transmitter

UART	Universal Asynchronous Receiver Transmitter
USB	Universal Serial Bus or Upper Side Band (depending on context)
VCO	Voltage Controlled Oscillator
VFBGA	Very Fine Ball Grid Array
VM	Virtual Machine
W-CDMA	Wideband Code Division Multiple Access

16 Document History

Revision	Date	History
BC41C671A-ds-001Pa	JAN 06	Original publication of this document
BC41C671A-ds-001Pb	FEB 06	Correction made to the guaranteed temperature range indicated in Recommended Operating Conditions, Electrical Characteristics
CS-111799-DSP1	JAN 07	Datasheet moved to Production status

BlueCore™4-Audio Flash

Product Data Sheet

CS-111799-DSP1

January 2007