

# Microphotonic Devices (Micro-displacement Sensor)

# Z4D-C01

CSM\_Z4D-C01\_DS\_E\_1\_2

## Micro-displacement Sensor

- Enable to detect  $\pm 10 \mu\text{m}$  level displacement, applicable to detect duplicated paper feeding or deflection amount.
- Displacement output changes by object colors are stabilized with signal divider circuit.
- Operating area =  $6.5 \pm 1 \text{ mm}$ .

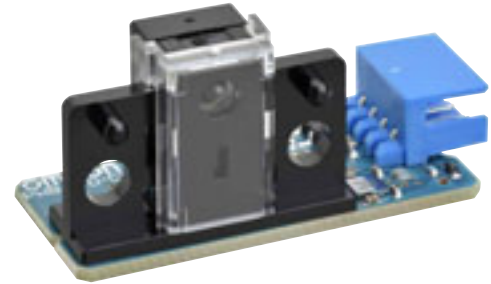

**⚠ Be sure to read *Safety Precautions* on page 3.**

## Ordering Information

### Micro-displacement Sensor

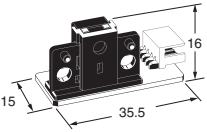
| Appearance  | Sensing method | Connecting method | Sensing distance       | Output type   | Model   |
|---|----------------|-------------------|------------------------|---------------|---------|
|  | Triangulation  | Connector         | $6.5 \pm 1 \text{ mm}$ | Analog output | Z4D-C01 |

## Ratings, Characteristics and Exterior Specifications

### Absolute Maximum Ratings ( $T_a = 25^\circ\text{C}$ )

| Item                                    | Symbol    | Rated value | Unit             | Remarks   |
|---|-----------|-------------|------------------|---|
| Supply voltage                          | $V_{CC}$  | 7           | V                | ---   |
| LED pulse light emission control signal | PLS       | 7           | V                | LED   |
| LED light emission pulse                | $t_{FP}$  | 100         | ms               | Please refer Pulsed Forward Current Rated Curve |
| Operating temperature                   | $T_{opr}$ | -10 to +65  | $^\circ\text{C}$ | No freezing or condensation                     |
| Storage temperature                     | $T_{stg}$ | -25 to +80  | $^\circ\text{C}$ | ---   |

Note: Refer to Pulsed Forward Current Rated Curve.

### Characteristics ( $T_a = 25^\circ\text{C}$ )

Object: N8.5 Munsell paper with a reflection factor of 70%.

| Item                     | Value   |
|--------------------------|---|
| Operating area *1        | $6.5 \pm 1 \text{ mm}$                              |
| Sensitivity variation *2 | $-1.4 \text{ mV}/\mu\text{m} \pm 10\% \text{ max.}$ |
| Resolution *3            | $\pm 10 \mu\text{m} \text{ max.}$                   |
| Linearity *4             | 2% F.S. (full scale) max.                           |

\*1. Distance from Mounting Reference Plane to Target.

\*2. The sensitivity is defined as slope of the line and it represents the variation in the output voltage per unit length between different products.

$$\text{Sensitivity variation} = \frac{V_1 - V_0}{2000} \quad (\text{mV}/\mu\text{m})$$

$V_0$ : Output voltage at the point  $d_0$   
 $V_1$ : Output voltage at the point  $d_1$   
 $d_0, d_1$ : Distance between datum clamp face and detective object

|       |        |
|-------|--------|
| $d_0$ | 5.5 mm |
| $d_1$ | 7.5 mm |

\*3. This is the value of the electrical noise width in the output signal converted to a distance under the following conditions.

- (1) Noise width is measured in a waveform after the four times average with an oscilloscope.
- (2) Ripple noise in the power supply voltage ( $V_{CC}$ ): 10 mVp-p max.
- (3) Distance from mounting reference plane to target: 6.5 mm
- (4) Resolution is measured by the voltage of response delay time ( $t_{r2}$ ).

\*4. This is the peak-to-peak value of the deviation of the signal output from a straight line.

A linearity of 2% F.S. indicates the following value:

- (1) Distance full-scale converted value:  $2 \text{ mm} \times 0.02 = 0.04 \text{ mm}$  (40  $\mu\text{m}$ )
- (2) Output voltage converted value:  $1.4 \text{ mV}/\mu\text{m} \times 40 \mu\text{m} = 56 \text{ mV}$  (for a sensor with a sensitivity of 1.4 mV/ $\mu\text{m}$ )

### Exterior Specification

| Connecting method | Weight (g) | Material      |               |      |
|-------------------|------------|---------------|---------------|------|
|                   |            | Case          | Cover         | Lens |
| Connector         | 3.6        | Polycarbonate | Polycarbonate | PMMA |

### Electrical and Optical Characteristics ( $T_a = -10^\circ\text{C}$ to $65^\circ\text{C}$ )

| Item  | Symbol   | Rated value                   | Remarks                      |
|---|----------|-------------------------------|------------------------------|
| Power supply voltage                            | $V_{CC}$ | 5 V $\pm 10\%$                | Ripple (p-p): 10 mV p-p max. |
| Output voltage                                  | OUT      | 0.2 V to ( $V_{CC} - 0.3$ ) V | *1                           |
| Response delay time                             | $t_{r1}$ | 100 $\mu\text{s}$ max.        | *2                           |
|   | $t_{r2}$ | 500 $\mu\text{s}$ max.        | *3                           |
| LED pulse light emission control signal voltage | PLS      | 3.5 V to $V_{CC}$             | ---                          |

\*1. Load impedance (between OUT-GND) is set at more than 10 k $\Omega$ .

\*2.  $t_{r1}$ : Rise time of output voltage from 10% to 90%.

\*3.  $t_{r2}$ : Setup time from PLS rising edge to measured output value rising edge.

## Engineering Data (Reference value)

**Fig 1. Operating Distance Characteristics (Typical)**

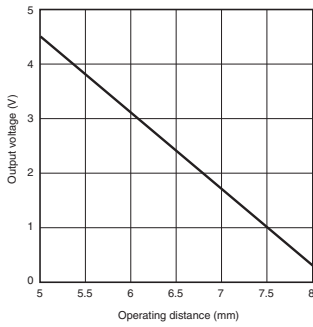

**Fig 2. Dependency of Object on Reflection Factor (Typical)**

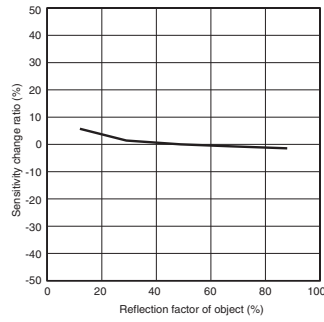

**Fig 3. Temperature Characteristics (Typical)**

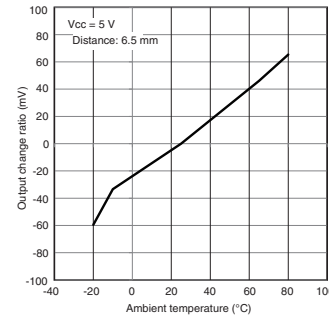

**Fig 4. Pulsed Forward Current Rated Curve**

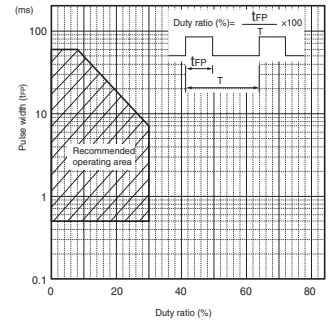

## Circuit diagram/Connection diagram

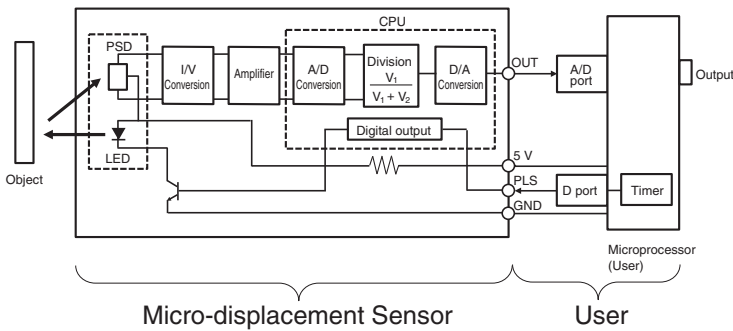

- Output voltage signal is obtained by applying the pulse signal at PLS terminal. Please be careful, it is not obtained by DC voltage applying.

## Pulse Input and Sensor Output

<Pulse Input>



<Sensor Output>

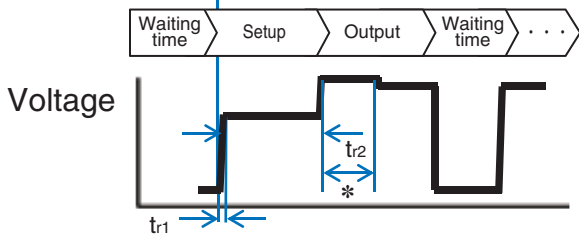

- Output voltage depends on input. After setup time  $t_{r2}$ , output signal is obtained according to the distance.
- After setup, output signal is updated every 80 micro seconds.

\* Update every 80 micro seconds. Output signal is reset at pulse input signal falling low level, and start setup over again after next input signal applying.

## Application Examples

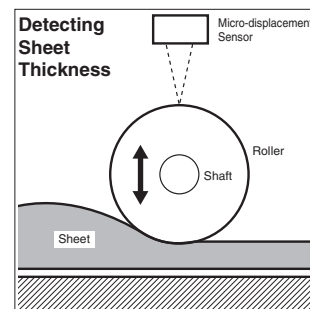
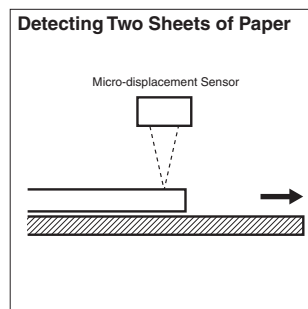
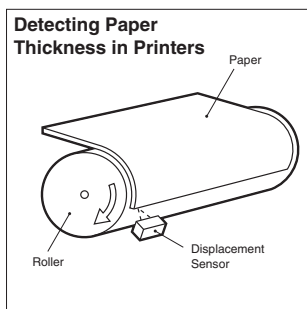

## Safety Precautions

To ensure safe operation, be sure to read and follow the Instruction Manual provided with the Sensor.

### CAUTION

This product is not designed or rated for ensuring safety of persons either directly or indirectly. Do not use it for such purposes.



### Precautions for Correct Use

Do not use the product in atmospheres or environments that exceed product ratings. This product is for surface mounting. Refer to Soldering Information, Storage and Baking for details.

Dispose of this product as industrial waste.

### Precautions for Safe Use

Do not use the product with a voltage or current that exceeds the rated range.

Applying a voltage or current that is higher than the rated range may result in explosion or fire.

Do not miswire such as the polarity of the power supply voltage.

Otherwise the product may be damaged or it may burn.

This product does not resist water. Do not use the product in places where water or oil may be sprayed onto the product.

## Dimensions

(Unit: mm)

### Micro-displacement Sensor

Z4D-C01

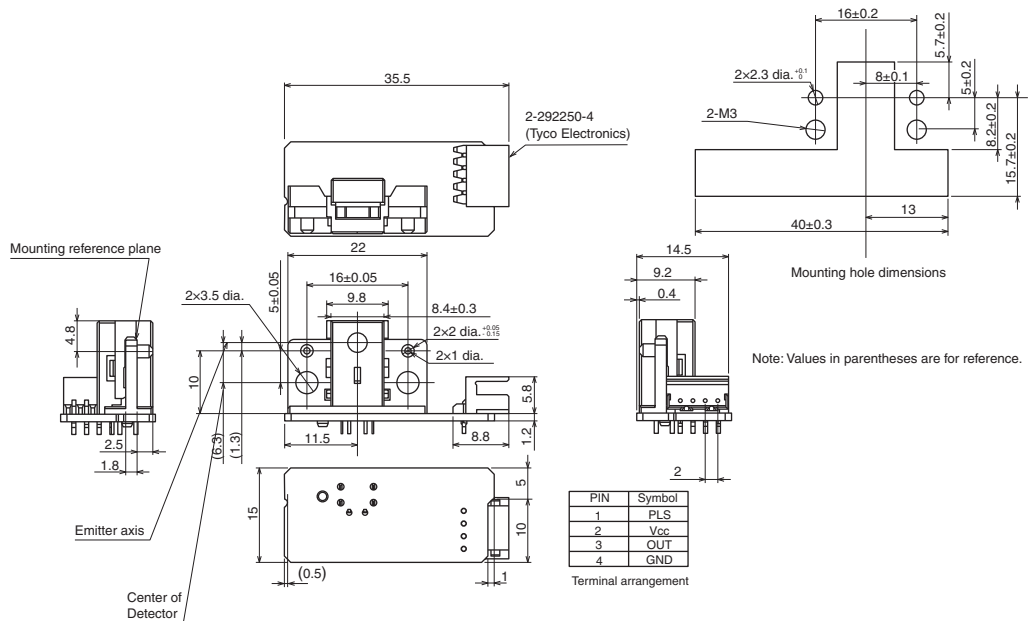

Recommended Mating Connectors: Tyco Electronics 175778-4 (crimp-type connector)  
173977-4 (insulation displacement crimp connector)