

SERIES: UJ2-AV-TH | **DESCRIPTION:** USB JACK

FEATURES

- USB type A jack
- vertical orientation
- through hole mounting



PART NUMBER KEY

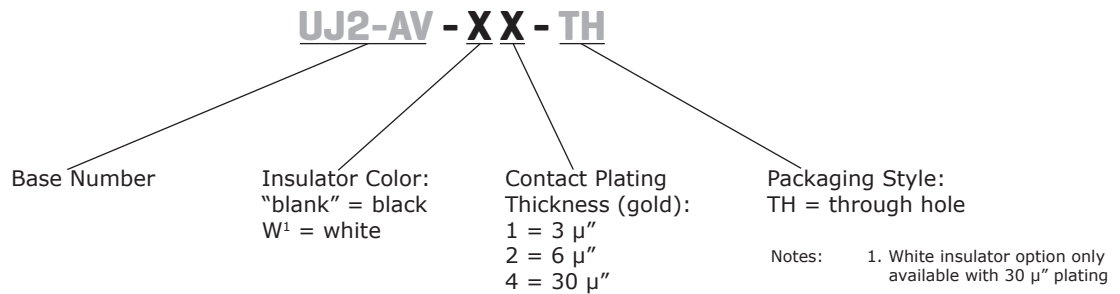

SPECIFICATIONS

parameter	conditions/description	min	typ	max	units
rated input voltage				30	Vac
rated input current				1.0	A
contact resistance ¹	between terminals and mating plug			30	mΩ
insulation resistance		1000			MΩ
voltage withstand	for 1 minute			500	Vac
insertion force				35	N
withdrawal force		10			N
operating temperature		-20		85	°C
life			1,500		cycles
flammability rating	UL94V-0				
RoHS	2011/65/EU				

Note: 1. When measured at 20 mV / 100 mA.
2. All specifications measured at 15~35°C, humidity at 25~85%, under atmospheric pressure of 86~106 kPa, unless otherwise noted.

SOLDERABILITY

parameter	conditions/description	min	typ	max	units
wave soldering	dipped in solder pot for 5 ±0.5 seconds		240		°C

MECHANICAL DRAWING

units: mm
 tolerance:
 X.X ±0.38 mm
 X.XX ±0.25 mm

	MATERIAL	PLATING
contact terminals	phosphor bronze	contact: gold over nickel solder: tin over nickel
shield	steel	nickel
insulator	PBT	

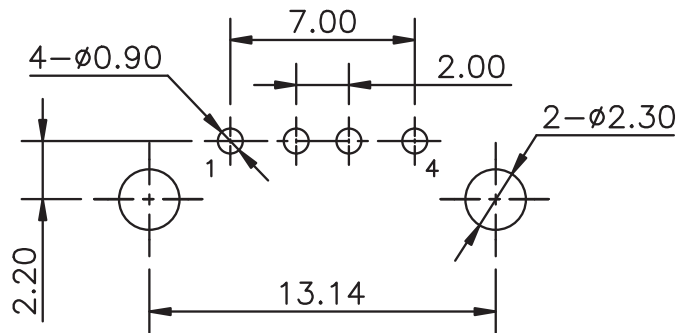
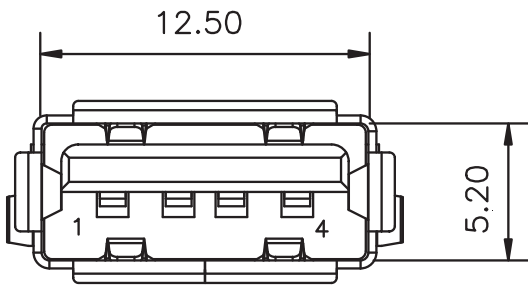
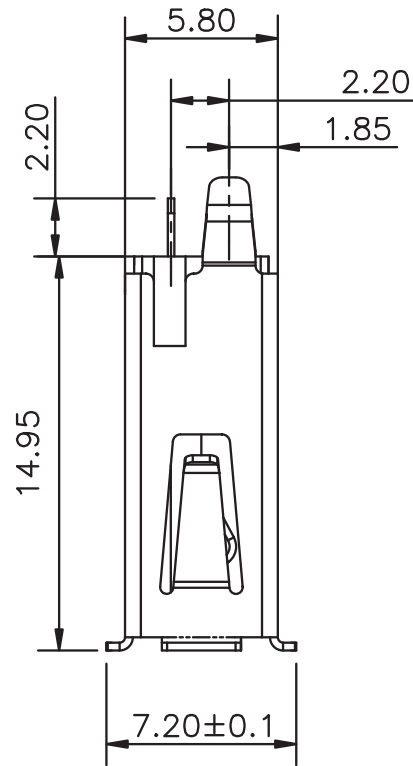
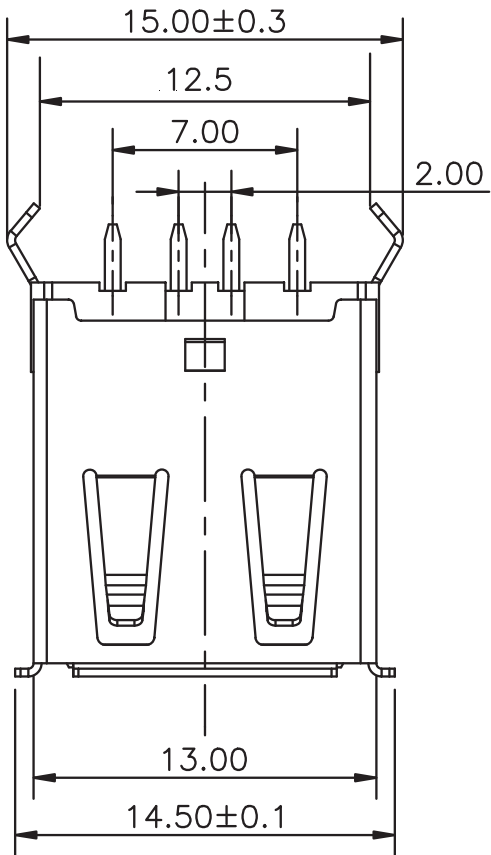

Recommended PCB Layout
 Top View

REVISION HISTORY

rev.	description	date
1.0	initial release	08/05/2016

The revision history provided is for informational purposes only and is believed to be accurate.



CUI INC[®]

Headquarters
20050 SW 112th Ave.
Tualatin, OR 97062
800.275.4899

Fax 503.612.2383
cui.com
techsupport@cui.com

CUI offers a one (1) year limited warranty. Complete warranty information is listed on our website.

CUI reserves the right to make changes to the product at any time without notice. Information provided by CUI is believed to be accurate and reliable. However, no responsibility is assumed by CUI for its use, nor for any infringements of patents or other rights of third parties which may result from its use.

CUI products are not authorized or warranted for use as critical components in equipment that requires an extremely high level of reliability. A critical component is any component of a life support device or system whose failure to perform can be reasonably expected to cause the failure of the life support device or system, or to affect its safety or effectiveness.