

P.C.B. LAYOUT

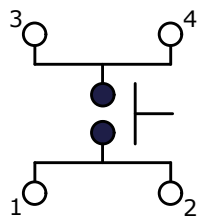
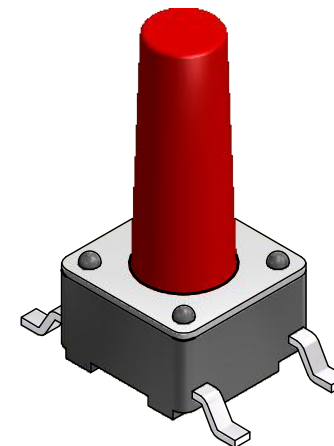
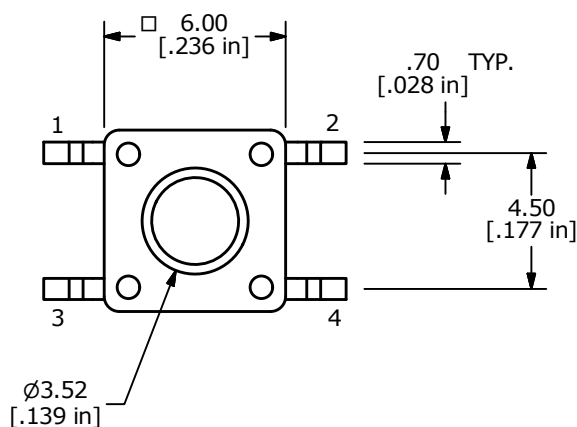

CIRCUIT: SPST

NOTES:

1. ALL DIMENSIONS IN MM
2. GENERAL TOLERANCE: X.X = ± 0.4
X.XX = ± 0.25
3. TERMINAL NUMBERS FOR REFERENCE ONLY.
4. RATING: 12VDC, 50mA
- ▲ 5. OPERATING FORCE: 260 \pm 50 gms
6. TRAVEL: 0.25mm +0.2/-0.1mm
7. CONTACT RESISTANCE: 100 MILLI OHMS MAX. (INITIAL)
8. MECHANICAL/ELECTRICAL LIFE: 100,000 CYCLES MIN
- ▲ 9. CONTACT MATERIAL: GOLD
10. 2011/65/EU (ROHS) COMPLIANT
- ▲ 11. PACKAGING: TAPE AND REEL/250 PIECES PER
12. ▲ DENOTES CRITICAL PARAMETER

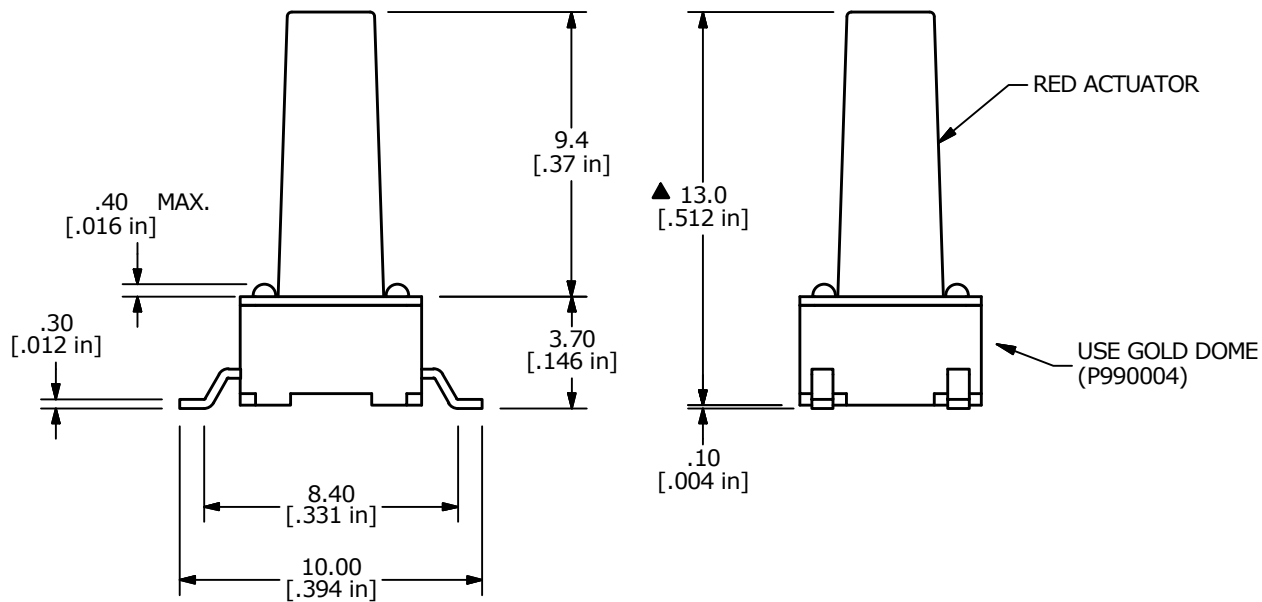

F	23277	Note 11: 750 to 250 pieces per	3/22/18	MW
E	23159	Redrawn, Force from 250 to 260gm	1/12/18	MW
REV	PCR NO	DESCRIPTION	DATE	BY

E-SWITCH®				
TITLE TL3301DF260RG (RED ACTUATOR)				
SCALE	DATE	DR	DWG	REV
4:1	11/13/2008	TN	P010616	F