

## 7 A VI Chip® EMI Filter SiP

### Product Description

The QPI-12 EMI filter is specifically designed to attenuate conducted common-mode (CM) and differential-mode (DM) noise of Vicor's VI Chip® products, such as the PRM®, VTM® and BCM® converters, to comply with the CISPR22 standard requirements for conducted noise measurements. The filter is designed to operate up to 80 Vdc, 100 Vdc surge, and supports 7 A loads up to 85°C (T<sub>A</sub>) without de-rating.

Designed for the telecom bus range, the VI Chip EMI filter supports the PICMG® 3.0 specification for filtering system boards to the EN55022 Class B limits.



Figure 1 — QPI-12LZ (~1/2 in<sup>2</sup> area)

### Features

- 45 dB CM attenuation at 1 MHz (50 Ω)
- 75 dB DM attenuation at 1 MHz (50 Ω)
- 80 Vdc (max input)
- 100 Vdc surge 100 ms
- 1,500 Vdc hipot hold off to shield plane
- 7 A rating
- 12.9 x 25.3 x 5.0 mm, lidded SiP (System-in-Package)
- 12.4 x 24.9 x 4.2 mm, open-frame
- Low profile LGA package
- -40° to +125°C PCB temperature (see Figure 6)
- Efficiency >99%
- TÜV Certified

### Applications

- VI Chip input EMI filter
- Telecom and ATCA boards

### Typical Applications

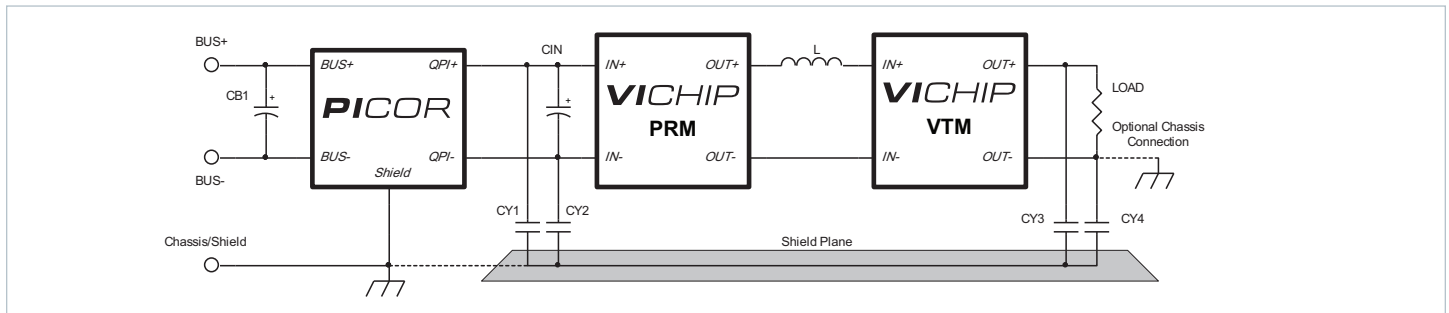

Figure 2 — Typical QPI-12 application schematic with Vicor's PRM and VTM modules. <sup>[a]</sup>

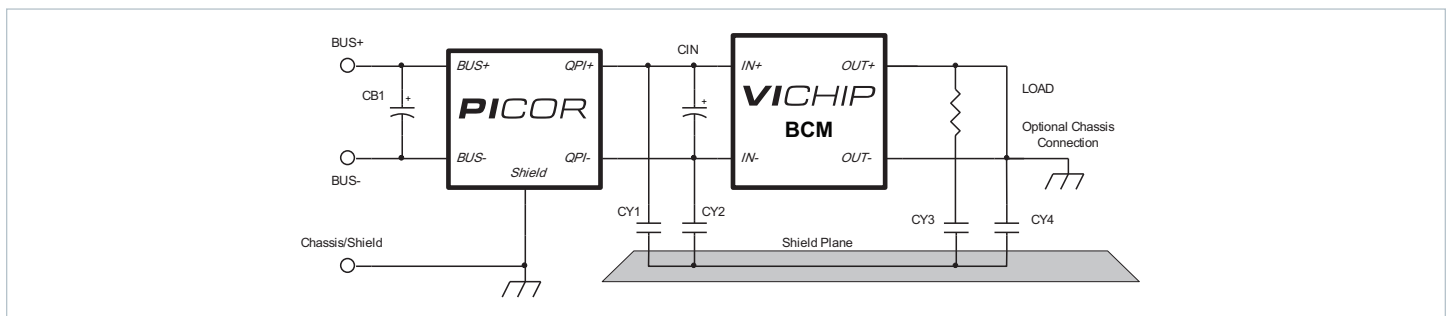

Figure 3 — Typical QPI-12 application schematic with Vicor's BCM module. <sup>[a]</sup>

<sup>[a]</sup> CB1 capacitor, referenced in all schematics, is a 47 μF electrolytic; United Chemi-Con EMVE101ARA470MKE05 or equivalent.

CY1 to CY4, referenced in all schematics, are 4.7 nF hi-voltage safety capacitors; Vishay VY1472M63Y5UQ63V0 or equivalent.

## Order Information

Part Number	Description
QPI-12LZ <sup>[b]</sup>	QPI-12 LGA package, RoHS compliant
QPI-12LZ-01	QPI-12 LGA package, RoHS compliant, open-frame package
<b>Evaluation Board Also Available</b>	
QPI-12-CB1	A QPI-12LZ mounted on a carrier board that can hold either a stand-alone BCM or a paired PRM/VTM eval board available from Vicor.

## Absolute Maximum Ratings

Exceeding these parameters may result in permanent damage to the product.

Name	Rating
Input voltage, BUS+ to BUS-, continuous	-80 to 80 Vdc
Input voltage, BUS+ to BUS-, 100 ms transient	-100 to 100 Vdc
BUS+/ BUS- to Shield pads, hipot	-1500 to 1500 Vdc
Input to output current, continuous @ 25°C (T <sub>A</sub> )	7 Adc
Power dissipation, @ 85°C (T <sub>A</sub> ), 7 A <sup>[c]</sup>	1.85 W
Operating temperature - T <sub>A</sub>	-40 to 125 °C
Thermal resistance <sup>[c]</sup> - R <sub>θJ-A</sub> , using PCB layout in Figure 25	30°C/W
Thermal resistance <sup>[c]</sup> - R <sub>θJ-PCB</sub>	18°C/W
Storage temperature, JEDEC Standard J-STD-033B	-55 to 125°C
Reflow temperature, 20 s exposure	245°C
ESD, Human Body Model (HBM)	-2000 to 2000 V

## Electrical Characteristics

Parameter limits apply over the operating temp. range, unless otherwise noted.

Parameter	Conditions	Min	Typ	Max	Unit
BUS+ to BUS-, input range	Measured at 7 A, 85°C ambient temperature <sup>[c]</sup>			80	Vdc
BUS+ to QPI+, voltage drop	Measured at 7 A, 85°C ambient temperature <sup>[c]</sup>			130	mVdc
BUS- to QPI-, voltage drop	Measured at 7 A, 85°C ambient temperature <sup>[c]</sup>			130	mVdc
Common-mode attenuation	V <sub>BUS</sub> = 48 V, frequency = 1.0 MHz, line impedance = 50 Ω	45			dB
Differential-mode attenuation	V <sub>BUS</sub> = 48 V, frequency = 1.0 MHz, line impedance = 50 Ω	75			dB
Input bias current at 50 V	Input current from BUS+ to BUS-			10	uA

<sup>[b]</sup> QPI-11LZ is a non-hermetically sealed package. Please read the "Post Solder Cleaning" section on Page 11.

<sup>[c]</sup> See Figure 6 for the current de-rating curve.

**Pad Descriptions**

Pin Name	Name	Description
8, 9	BUS+	Positive bus potential
1, 10	BUS-	Negative bus potential
6, 7	QPI+	Positive input to the converter
4, 5	QPI-	Negative input to the converter
2, 3	Shield	Shield connects to the system chassis or to a safety ground

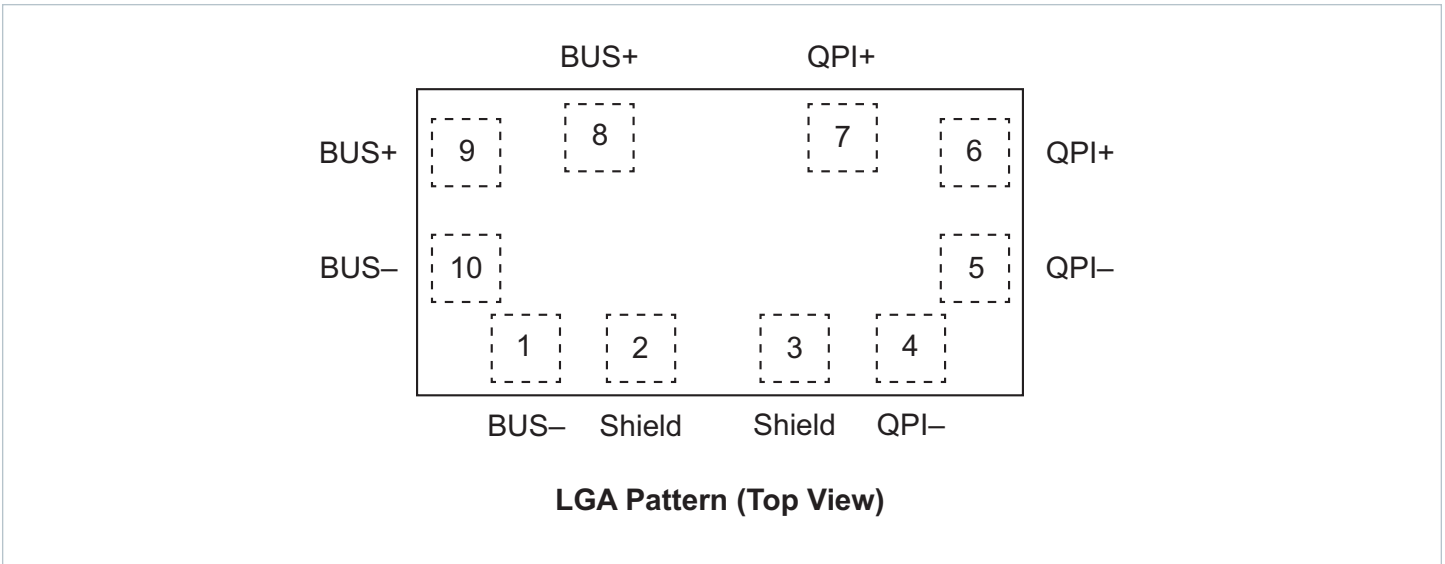

## Applications Information

### EMI Sources

Many of the components in today's power conversion modules are sources of high-frequency EMI noise generation. Diodes, high-frequency switching devices, transformers and inductors, and circuit layouts passing high  $dv/dt$  or  $di/dt$  signals are all potential sources of EMI.

EMI is propagated either by radiated or conductive means. Radiated EMI can be sourced from these components as well as by circuit loops that act like antennas and broadcast the noise signals to neighboring circuit paths. This also means that these loops can act as receivers of a broadcasted signal. This radiated EMI noise can be reduced by proper circuit layout and by shielding potential sources of EMI transmission.

There are two basic forms of conducted EMI that typically need to be filtered; namely common-mode (CM) and differential-mode (DM) EMI. Differential-mode resides in the normal power loop of a power source and its load; where the signal travels from the source to the load and then returns to the source. Common-mode is a signal that travels through both leads of the source and is returned to earth via parasitic pathways, either capacitively or inductively coupled.

Figure 10 to Figure 17 are the resulting EMI plots of the total noise, both common and differential mode, of Vicor's PRM/VTM and BCM<sup>®</sup> evaluation modules, under various loads, after filtering by the QPI-12LZ. The red and blue traces represent the positive and negative branches of total noise, as measured using an industry standard LISN setup, shown in Figures 4 and 5. The PRM<sup>®</sup> and VTM<sup>®</sup> evaluation boards are mounted to a Picor<sup>®</sup> QPI-12-CB1 board for testing. The QPI-12CB1 carrier is designed to accept both the PRM/VTM combination of evaluation boards, as well as the stand-alone BCM evaluation board.

The differential-mode EMI is typically larger in magnitude than common-mode, since common-mode is created by the physical imbalances in the differential loop path. Reducing differential EMI will cause a reduction in common-mode EMI.

### EMI Filtering

The basic premise of filtering EMI is to insert a high-impedance, at the EMI's base frequency, in both the differential and common-mode paths as it returns to the power source.

Passive filters use common-mode chokes and "Y" capacitors to filter out common-mode EMI. These chokes are designed to present a high-impedance at the EMI frequency in series with the return path, and a low impedance path to the earth signal via the "Y" caps. This network will force the EMI signals to re-circulate within a confined area and not to propagate to the outside world. Often two common-mode networks are required to filter EMI within the frequency span required to pass the EN55022 Class B limits.

The other component of the passive filter is the differential LC network. Again, the inductor is chosen such that it will present a high-impedance in the differential EMI loop at the EMI's base frequency. The differential capacitor will then shunt the EMI back to its source. The QPI-12 was specifically designed to work with higher switching frequency converters like Vicor's VI Chip<sup>®</sup> products; PRM, VTM and BCM modules; as well as their newer VI Brick<sup>™</sup> product series.

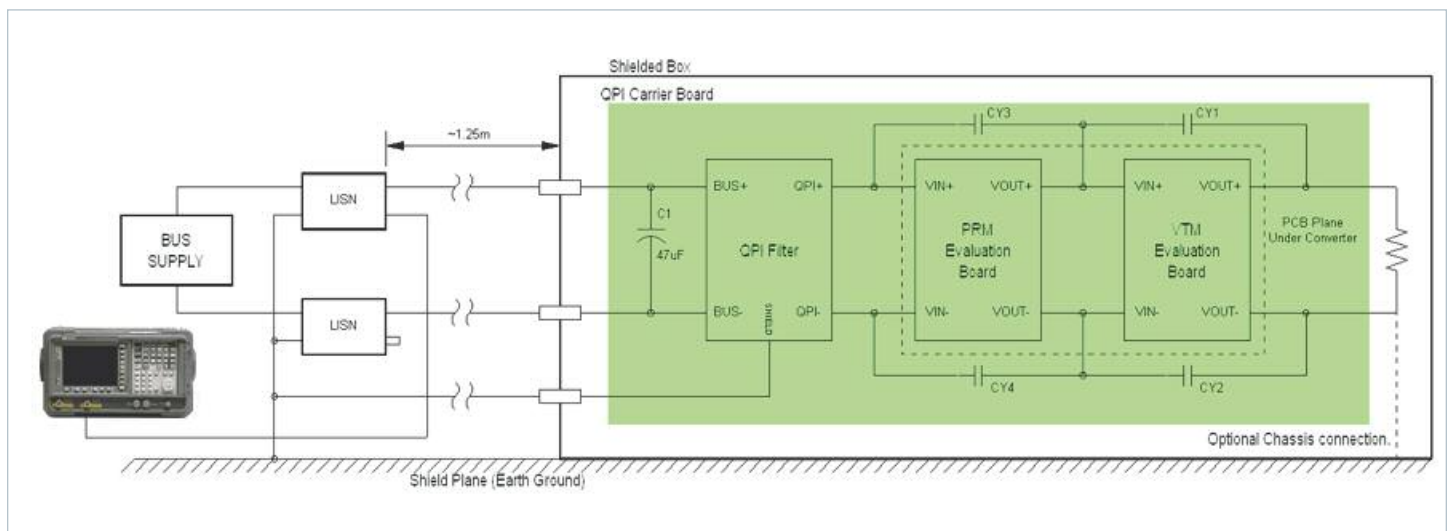

**Figure 4** — Open-frame EMI test setup using the QPI-12-CB1 carrier board with VI Chip evaluation boards.

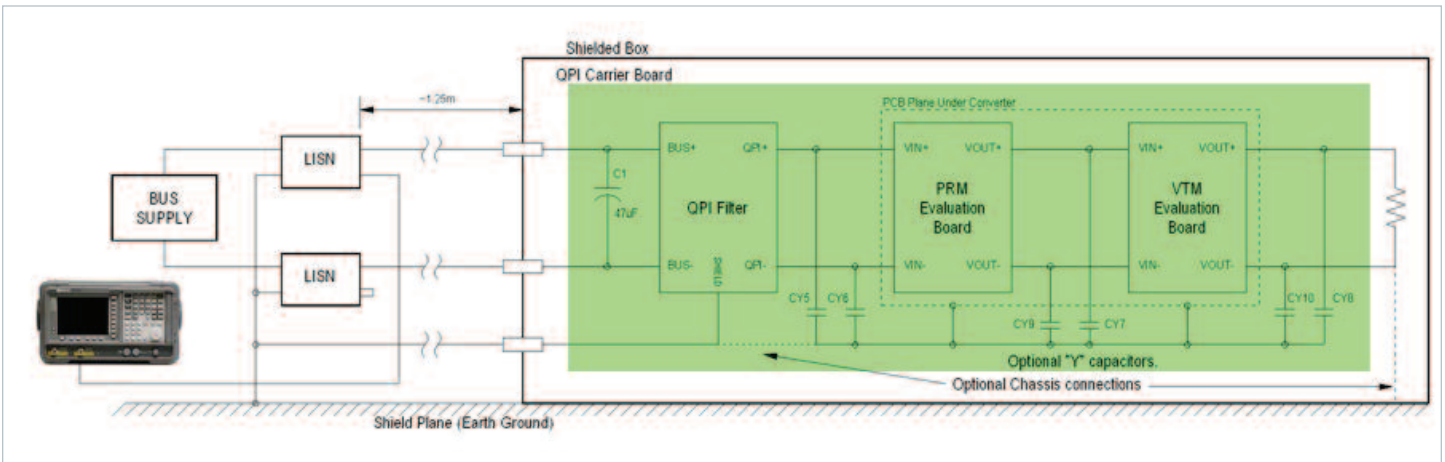

Figure 5 — Baseplate EMI test setup using the QPI-12-CB1 carrier board with VI Chip evaluation boards.

**EMI Management**

The more effectively EMI is managed at the source, namely the power converter, the less EMI attenuation the filter will have to do. The addition of “Y” capacitors to the input and output power nodes of the converter will help to limit the amount of EMI that tries to propagate to the input source.

There are two basic topologies for the connection of the recirculating “Y” capacitors. In Figure 4 the open-frame topology is shown in Picor’s EMI test setup. The “Y” capacitors (CY1 to CY4) recirculate the EMI signals between the positive input and output, and the negative input and output of the power conversion stage.

Figure 5 shows the baseplate topology of recirculating “Y” caps. Here, CY5 to CY10 are connected to each power node of the PRM and VTM, and then are commoned together on a copper shield plane created under the converter. The addition of the copper shield plane helps in the containment of the radiated EMI, converting it back to conducted EMI and shunting it back to its source.

Both of these topologies work well with the PRM/VTM combination shown above in attenuating noise levels well below Class B EMI limits.

**Current De-Rating** — Mounted to QPI-12-CB1 Evaluation Board

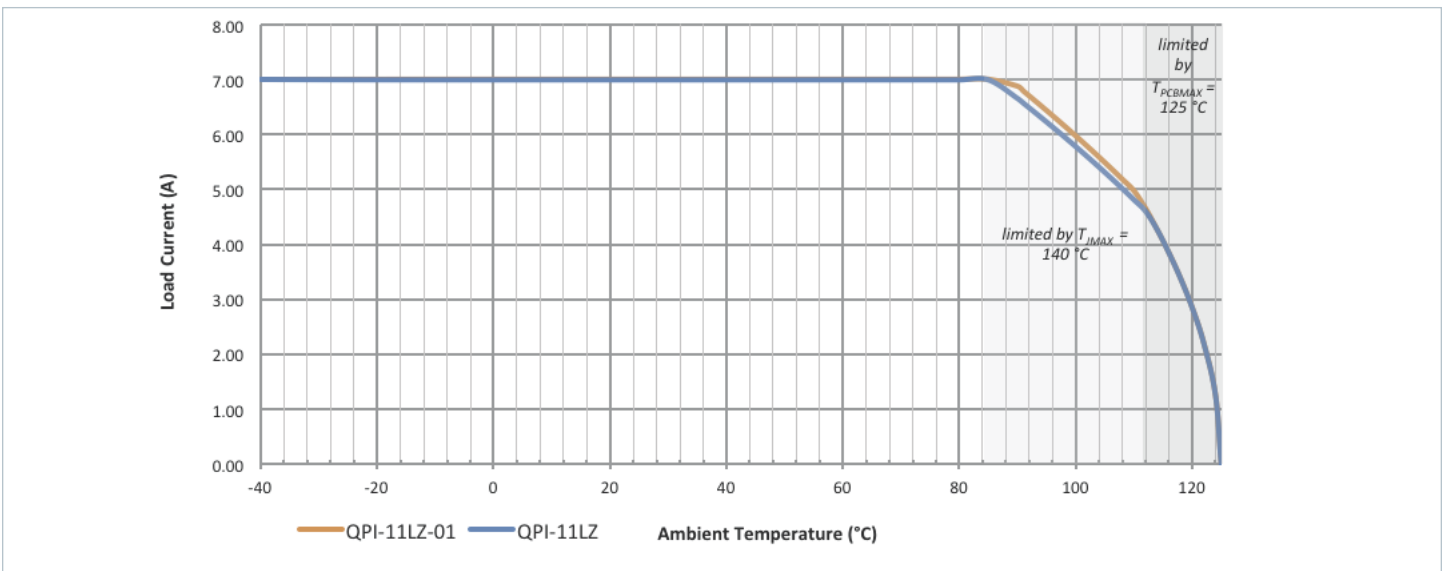

Figure 6 — Current de-rating over ambient temperature range.

QPI Insertion Loss Measurements

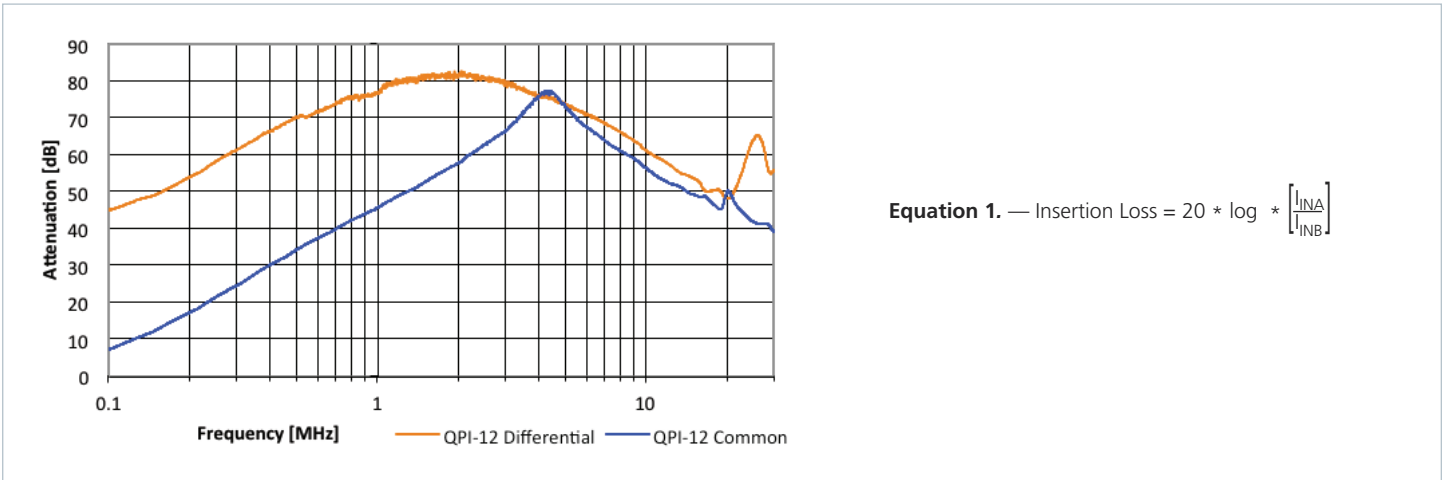

Figure 7 — Attenuation curves into a 50 Ω line impedance, bias from a 48 V bus.

QPI Insertion Loss Test Circuits

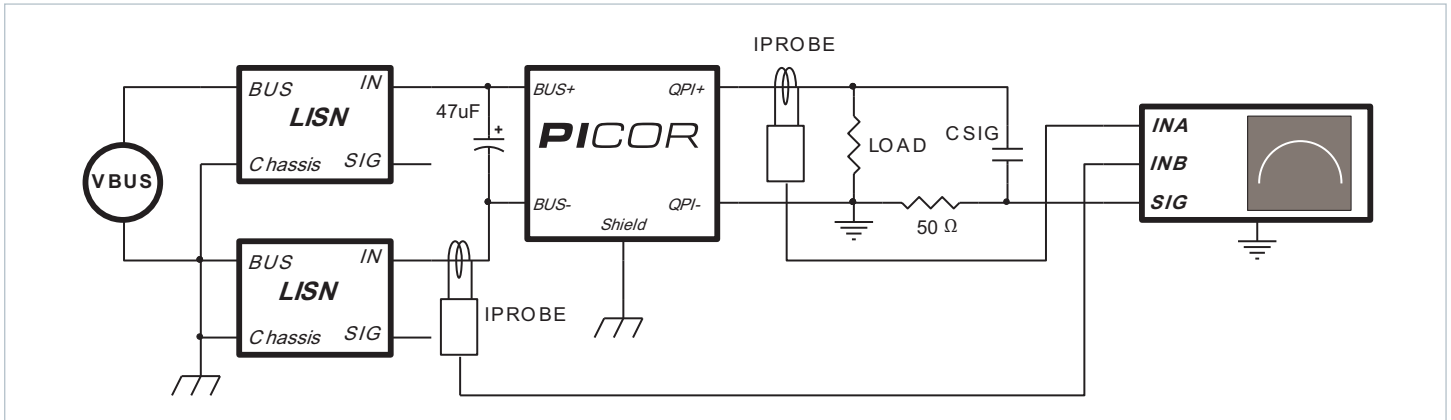

Figure 8 — Test set up to measure differential-mode EMI currents in Figure 7.

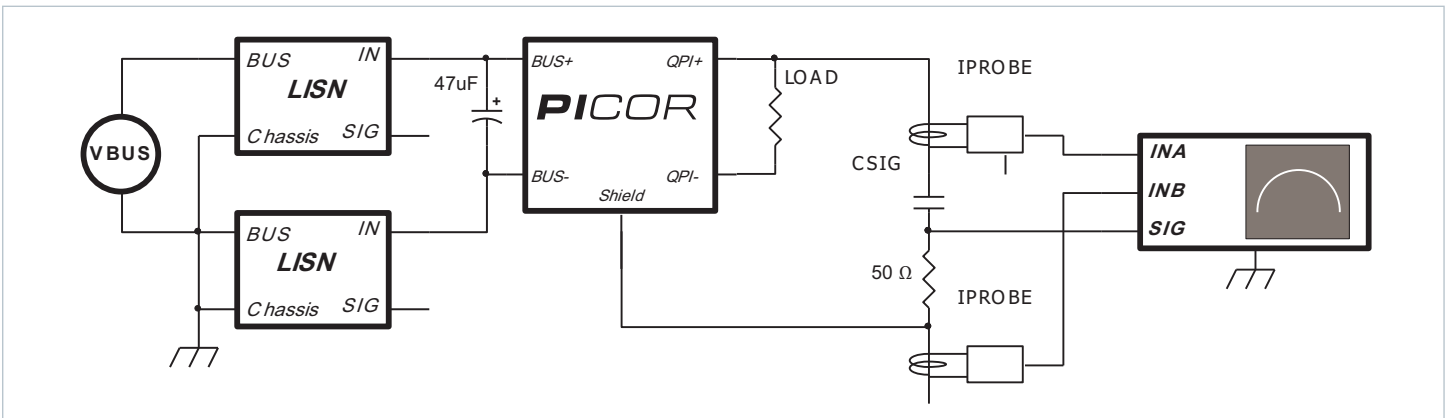
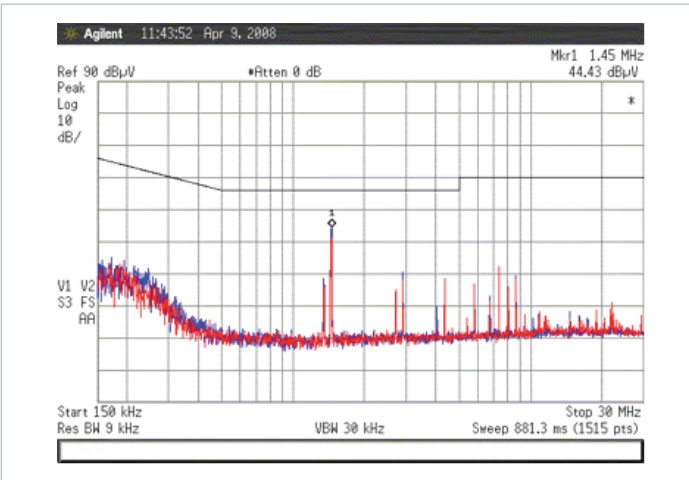
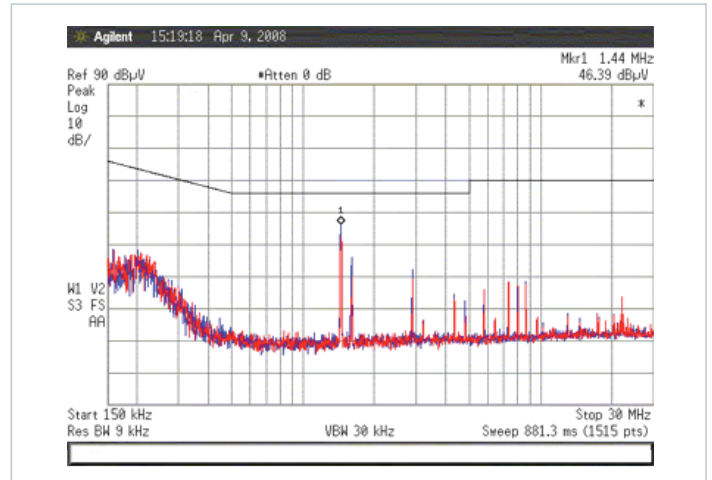

Figure 9 — Test set up to measure common-mode EMI currents in Figure 7.

**Attenuation Plots** — QPI-12 with PRM P048F048T24AL-CB and various VTM modules, connected in baseplate configuration, as shown in Figure 4.



**Figure 10** — VTM V048F030T070-CB with 160 W load.



**Figure 11** — VTM V048F120T025-CB with 180 W load.

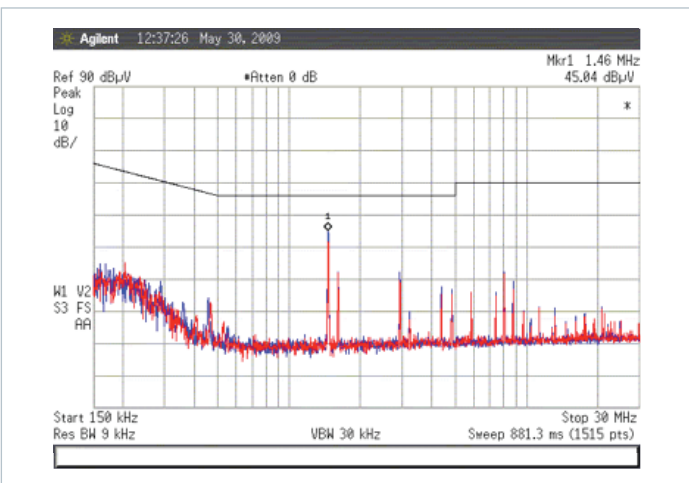

**Figure 12** — VTM V048F240T012-CB with 172 W output load.

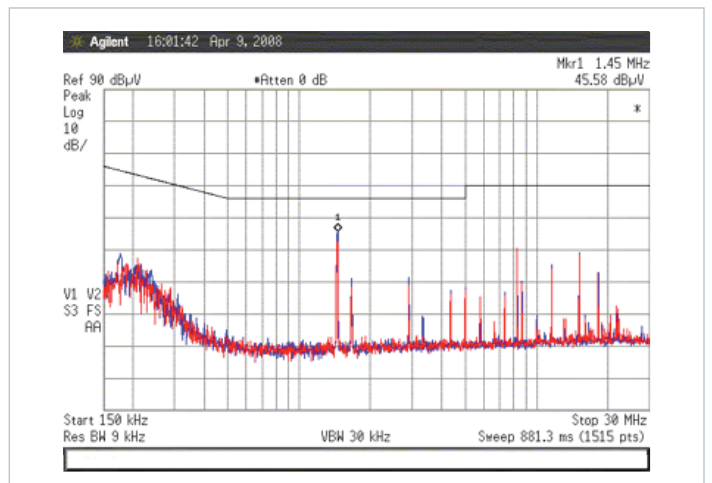

**Figure 13** — VTM V048F480T006-CB with 153 W load.



**Attenuation Plots** — QPI-12 with various BCM modules, connected in open frame configuration, as shown in Figure 18.

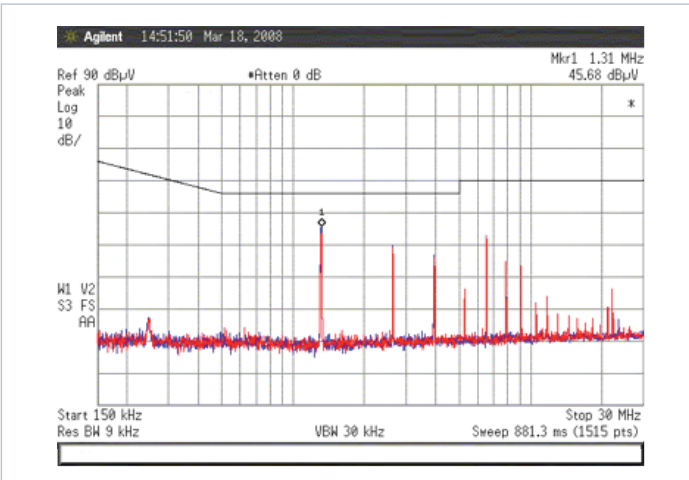

**Figure 14** — BCM B048F030T21-EB with 160 W load.

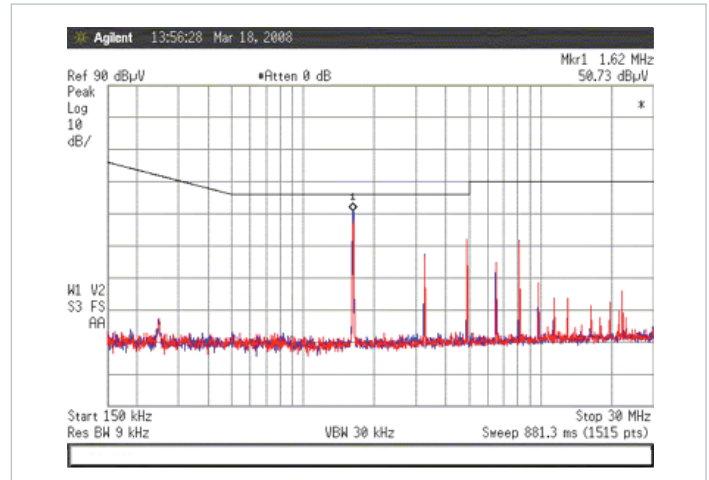

**Figure 15** — BCM B048F120T30-EB with 180 W load.

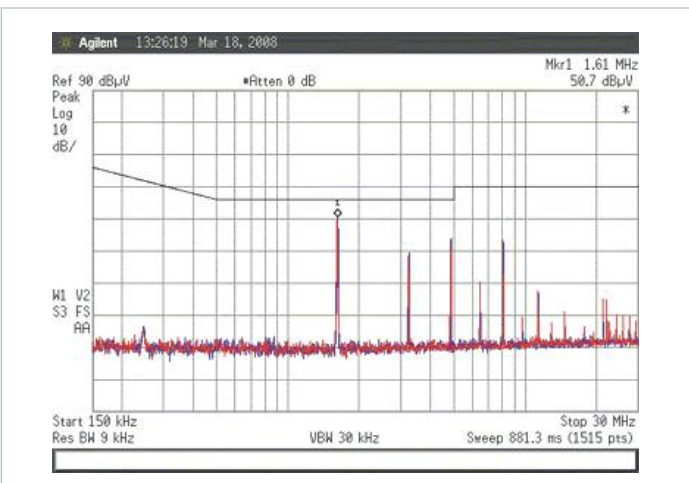

**Figure 16** — BCM B048F240T30-EB with 172 W load.

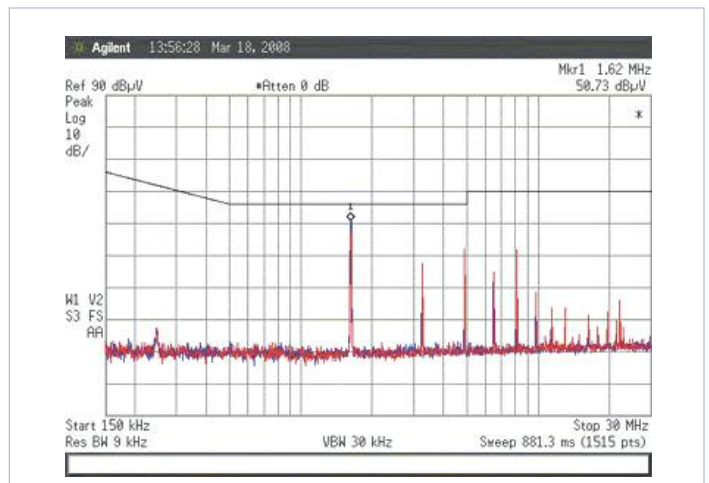

**Figure 17** — BCM B048F480T30-EB with 152 W load.

The red and blue traces in Figure 10 through Figure 17 are the measurements of total EMI, in both the positive and negative branches. The test setups shown in Figure 4 and Figure 5 are representative of measuring the positive branch of the total EMI for the unit under test.



Converter Output Grounding — Recommended configurations

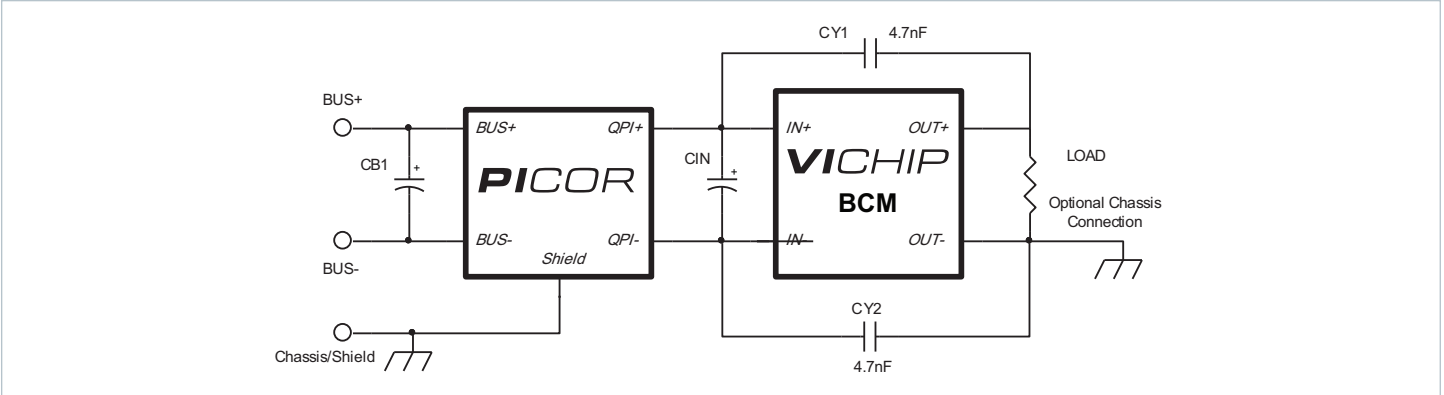

Figure 18 — BCM converter in open-frame configuration with the output connected to chassis/earth.

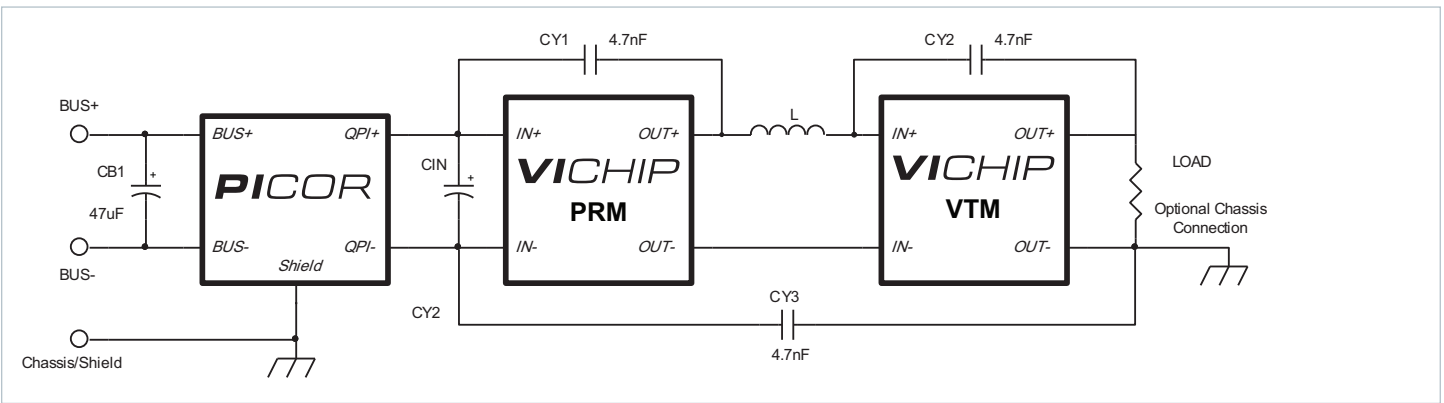

Figure 19 — PRM/VTM in open-frame configuration with the output connected to the chassis/earth.

When using the QPI-12 with a Vicor PRM/VTM or BCM, in a power system that requires the converter's output to be connected to chassis/earth, Picor recommends using the open-frame configuration of "Y" capacitors, shown in Figure 18, to re-circulate EMI currents. A base-plate configuration could also be used with a slight decrease in EMI attenuation, but with peaks well below class B limits.

The plot in Figure 20 is of a B048F120T30, with a 125W load, with the output ground connected to the chassis. When using the open-frame configuration of "Y" caps, the EMI shield plane is not used by the "Y" capacitors for recirculating EMI currents.

This configuration would also be recommended for a QPI-12 with a PRM/VTM pair, configured as shown in Figure 2.

The QPI-12 is not designed to be used in parallel with another QPI-12 to achieve a higher current rating, but it can be used multiple times within a system design.

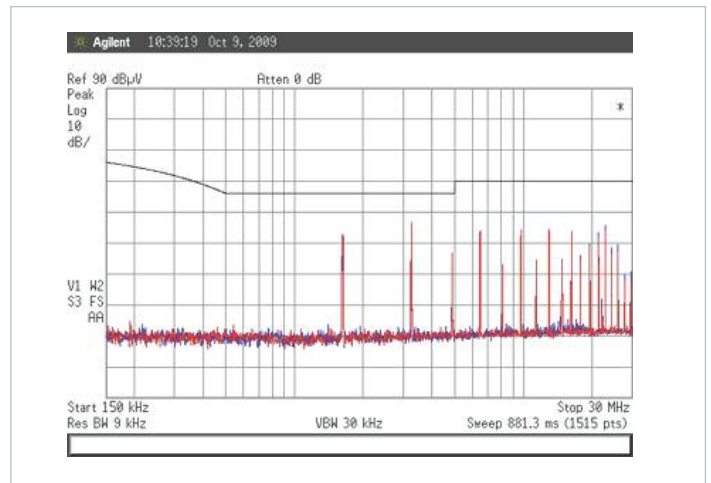
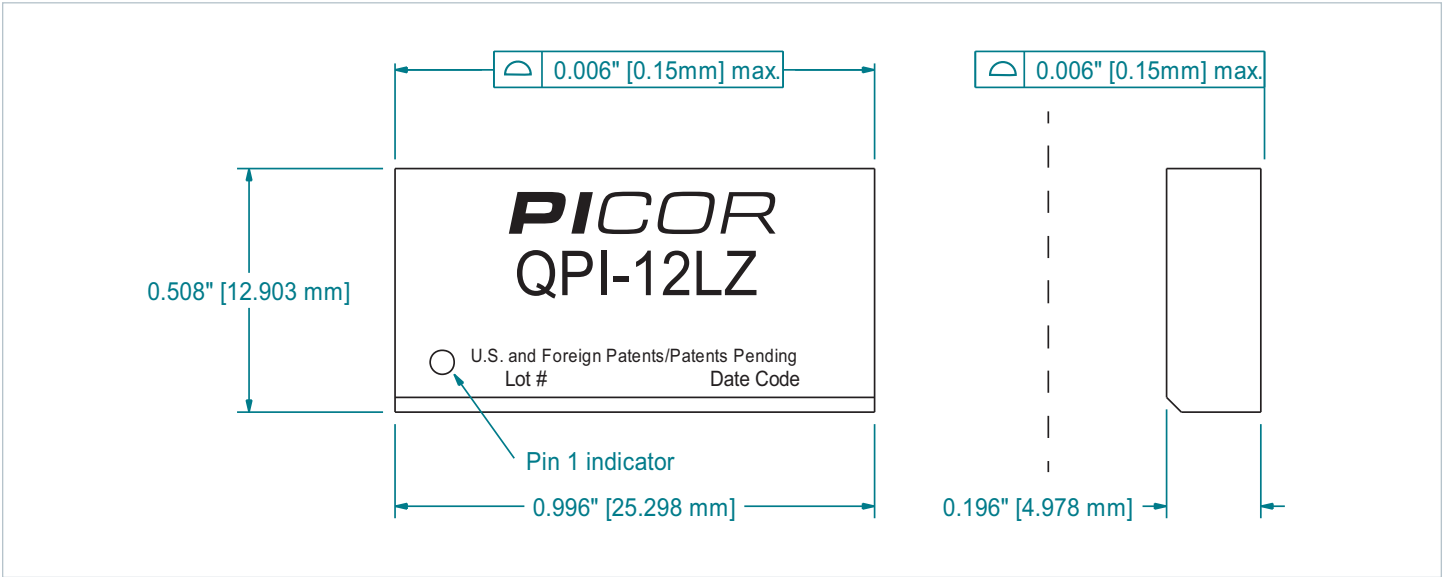
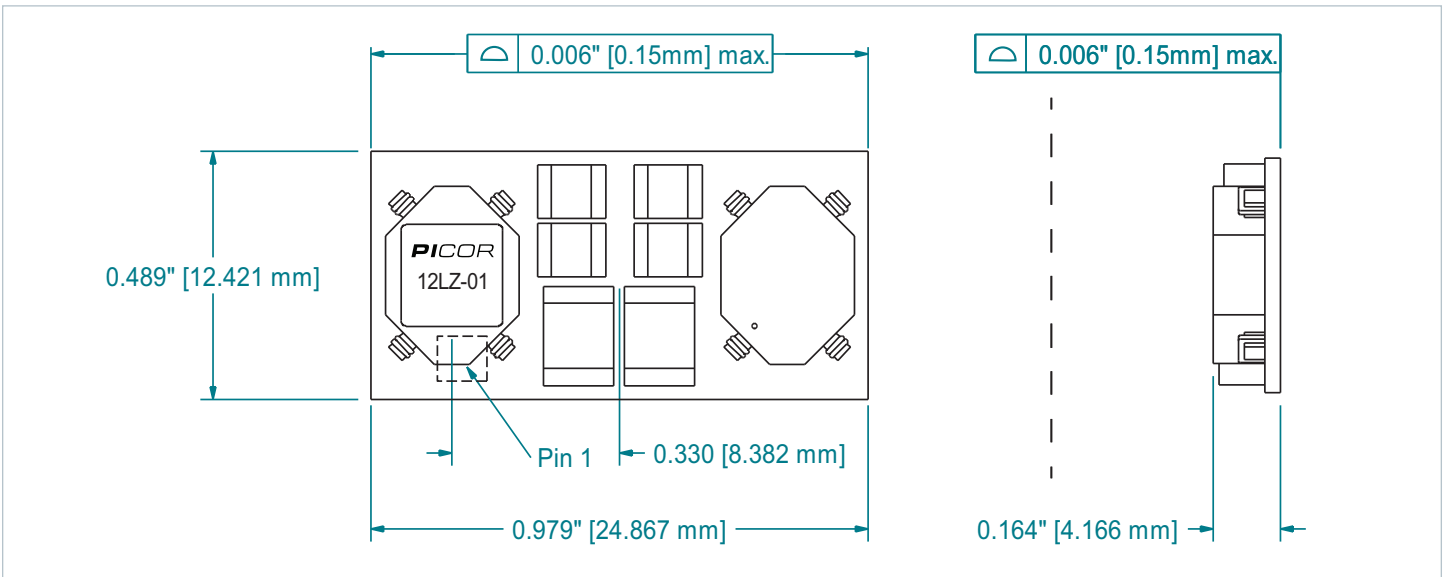

Figure 20 — Total noise plot of BCM with its output return connected to chassis, as shown in Figure 18, 125 W load.

**Mechanical Package Drawings**



**Figure 21** — Lidded package dimensions, tolerance of  $\pm 0.004$ "



**Figure 22** — Open open-frame package dimensions, tolerance of  $\pm 0.004$ ". Pick and place from label center.

Datum	Units	QPI-12LZ	QPI-12LZ-01	Notes
FITS	failure/billion hrs.	16	16	FITS based on the BellCore Standard TR-332
MTBF	million hrs.	62.5	62.5	MTBFs based on the BellCore Standard TR-332
Weight	grams	2.4	2.075	
MSL		3	3	
Peak Reflow Temperature	°C/20 seconds	245	245	IPC/JEDEC J-STD-020D

Pad and Stencil Definitions

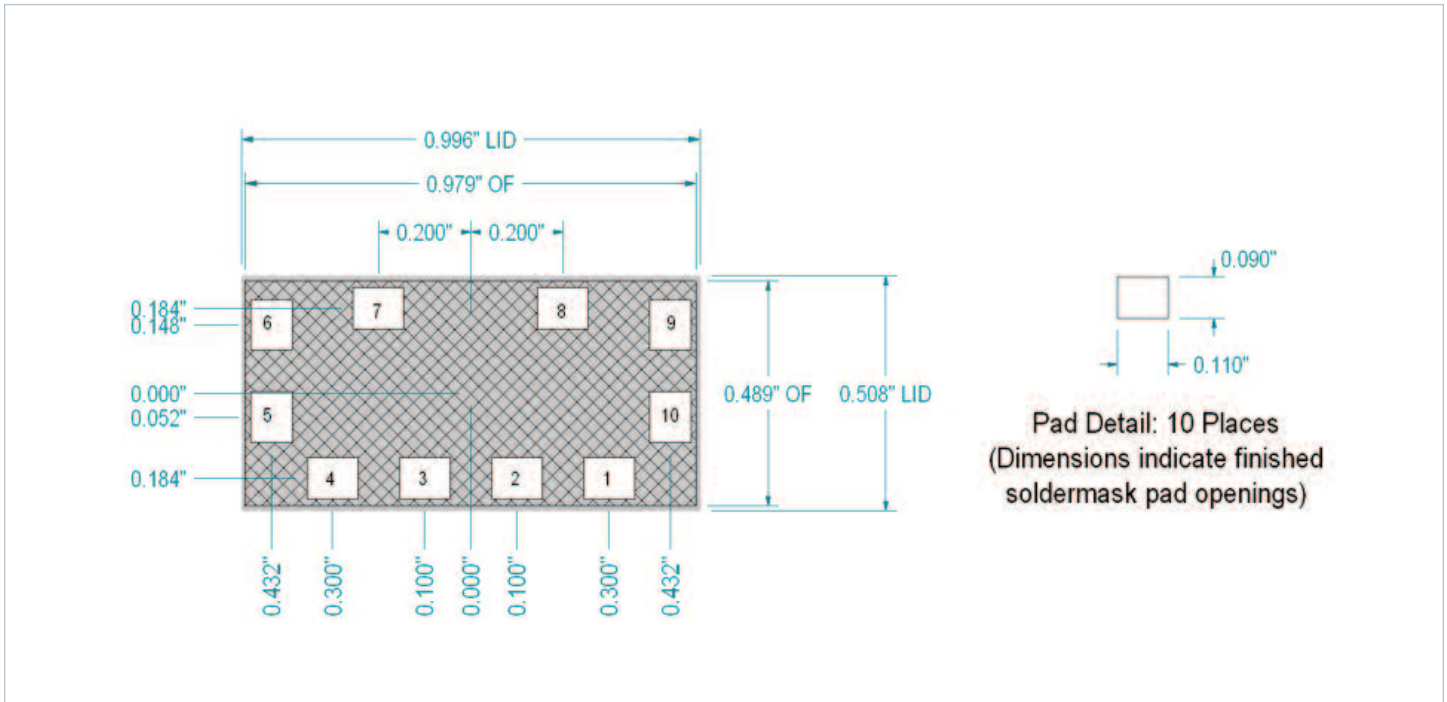

Figure 23 — Bottom view of open-frame (OF) and lidded (LID) products. (All dimensions are in inches)

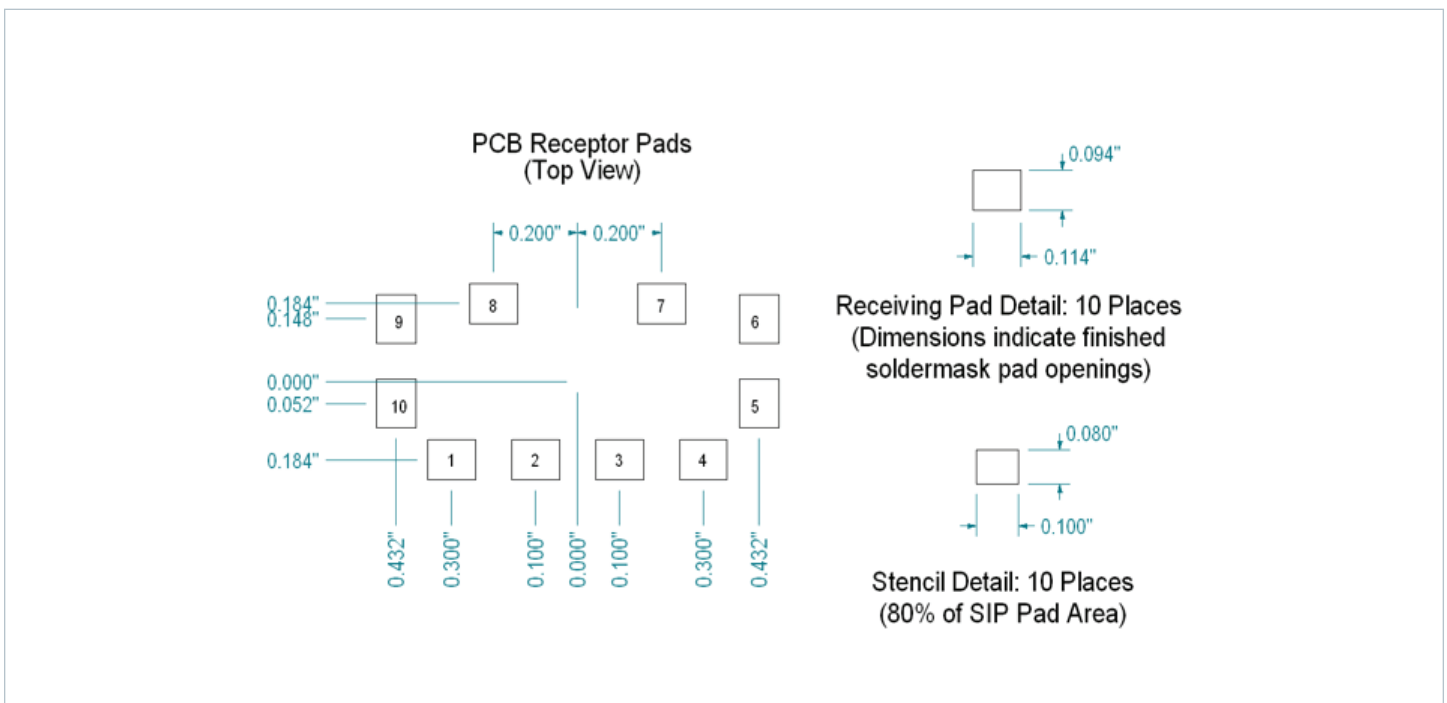
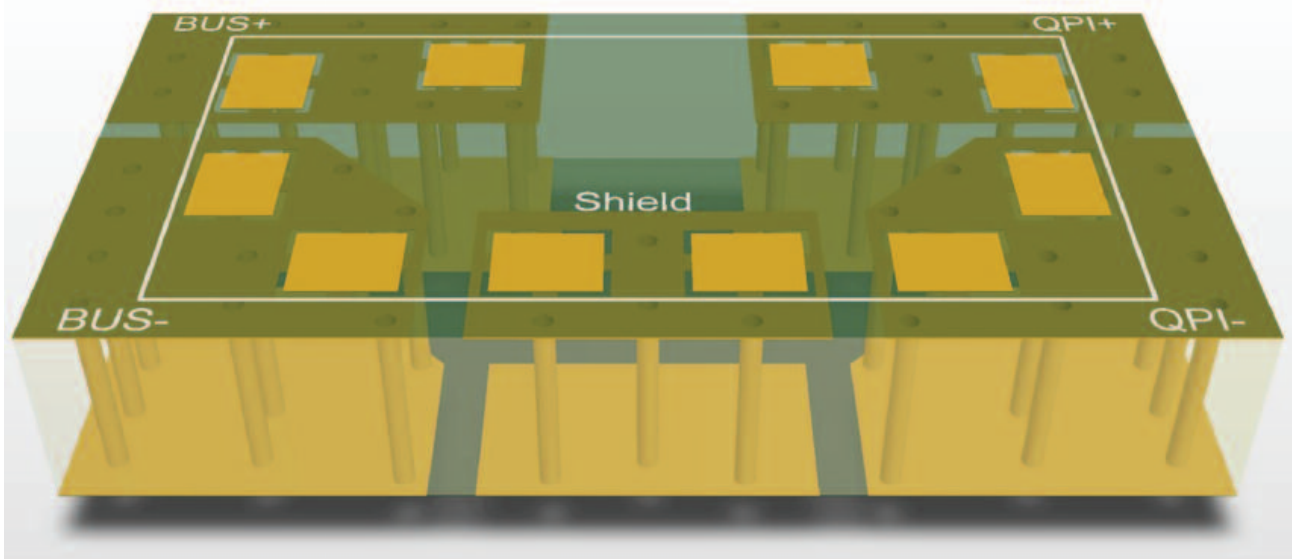

Figure 24 — Recommended receptor and stencil patterns. (All dimensions are in inches)

Stencil definition is based on a 6 mil stencil thickness, 80% of LGA pad area coverage. LGA package dimensions are for both the open-frame and lidded versions of the QPI-12.

## QPI-12 PCB Layout Recommendations



**Figure 25** — 3D view of paralleling planes underneath the QPI-12.

The filtering performance of the [QPI-12](#) is sensitive to capacitive coupling between its input and output pins. Parasitic plane capacitance must be kept below one pico-Farad between inputs and outputs using the layout shown above and the recommendations described below to achieve maximum conducted EMI performance.

To avoid capacitive coupling between input and output pins, there should not be any planes or large traces that run under both input and output pins, such as a ground plane or power plane. For example, if there are two signal planes or large traces where one trace runs under the input pins, and the other under the output pins, and both planes overlap in another area, they will cause capacitive coupling between input and output pins. Also, planes that run under both input and outputs pins, but do not cross, can cause capacitive coupling if they are capacitively by-passed together. Figure 25 shows

the recommended PCB layout on a two-layer board. Here, the top layer planes are duplicated on the bottom layer so that there can be no overlapping of input and output planes. This method can be used for boards of greater layer count.

### Post Solder Cleaning

Picor's LZ version QuitePower SiPs are not hermetically sealed and must not be exposed to liquid, including but not limited to cleaning solvents, aqueous washing solutions or pressurized sprays. When soldering, it is recommended that no-clean flux solder be used, as this will ensure that potentially corrosive mobile ions will not remain on, around, or under the module following the soldering process. For applications where the end product must be cleaned in a liquid solvent, Picor recommends using the QPI-12LZ-01, open-frame version of the EMI filter.

## **Vicor's comprehensive line of power solutions includes high density AC-DC and DC-DC modules and accessory components, fully configurable AC-DC and DC-DC power supplies, and complete custom power systems.**

Information furnished by Vicor is believed to be accurate and reliable. However, no responsibility is assumed by Vicor for its use. Vicor makes no representations or warranties with respect to the accuracy or completeness of the contents of this publication. Vicor reserves the right to make changes to any products, specifications, and product descriptions at any time without notice. Information published by Vicor has been checked and is believed to be accurate at the time it was printed; however, Vicor assumes no responsibility for inaccuracies. Testing and other quality controls are used to the extent Vicor deems necessary to support Vicor's product warranty. Except where mandated by government requirements, testing of all parameters of each product is not necessarily performed.

**Specifications are subject to change without notice.**

### **Vicor's Standard Terms and Conditions**

All sales are subject to Vicor's Standard Terms and Conditions of Sale, which are available on Vicor's website or upon request.

### **Product Warranty**

In Vicor's standard terms and conditions of sale, Vicor warrants that its products are free from non-conformity to its Standard Specifications (the "Express Limited Warranty"). This warranty is extended only to the original Buyer for the period expiring two (2) years after the date of shipment and is not transferable.

UNLESS OTHERWISE EXPRESSLY STATED IN A WRITTEN SALES AGREEMENT SIGNED BY A DULY AUTHORIZED VICOR SIGNATORY, VICOR DISCLAIMS ALL REPRESENTATIONS, LIABILITIES, AND WARRANTIES OF ANY KIND (WHETHER ARISING BY IMPLICATION OR BY OPERATION OF LAW) WITH RESPECT TO THE PRODUCTS, INCLUDING, WITHOUT LIMITATION, ANY WARRANTIES OR REPRESENTATIONS AS TO MERCHANTABILITY, FITNESS FOR PARTICULAR PURPOSE, INFRINGEMENT OF ANY PATENT, COPYRIGHT, OR OTHER INTELLECTUAL PROPERTY RIGHT, OR ANY OTHER MATTER.

This warranty does not extend to products subjected to misuse, accident, or improper application, maintenance, or storage. Vicor shall not be liable for collateral or consequential damage. Vicor disclaims any and all liability arising out of the application or use of any product or circuit and assumes no liability for applications assistance or buyer product design. Buyers are responsible for their products and applications using Vicor products and components. Prior to using or distributing any products that include Vicor components, buyers should provide adequate design, testing and operating safeguards.

Vicor will repair or replace defective products in accordance with its own best judgment. For service under this warranty, the buyer must contact Vicor to obtain a Return Material Authorization (RMA) number and shipping instructions. Products returned without prior authorization will be returned to the buyer. The buyer will pay all charges incurred in returning the product to the factory. Vicor will pay all reshipment charges if the product was defective within the terms of this warranty.

### **Life Support Policy**

VICOR'S PRODUCTS ARE NOT AUTHORIZED FOR USE AS CRITICAL COMPONENTS IN LIFE SUPPORT DEVICES OR SYSTEMS WITHOUT THE EXPRESS PRIOR WRITTEN APPROVAL OF THE CHIEF EXECUTIVE OFFICER AND GENERAL COUNSEL OF VICOR CORPORATION. As used herein, life support devices or systems are devices which (a) are intended for surgical implant into the body, or (b) support or sustain life and whose failure to perform when properly used in accordance with instructions for use provided in the labeling can be reasonably expected to result in a significant injury to the user. A critical component is any component in a life support device or system whose failure to perform can be reasonably expected to cause the failure of the life support device or system or to affect its safety or effectiveness. Per Vicor Terms and Conditions of Sale, the user of Vicor products and components in life support applications assumes all risks of such use and indemnifies Vicor against all liability and damages.

### **Intellectual Property Notice**

Vicor and its subsidiaries own Intellectual Property (including issued U.S. and Foreign Patents and pending patent applications) relating to the products described in this data sheet. No license, whether express, implied, or arising by estoppel or otherwise, to any intellectual property rights is granted by this document. Interested parties should contact Vicor's Intellectual Property Department.

The products described on this data sheet are protected by the following U.S. Patents Number:  
6,898,092

**Vicor Corporation**  
25 Frontage Road  
Andover, MA 01810 USA

**Picor Corporation**  
51 Industrial Drive  
North Smithfield, RI 02896 USA

#### **email**

Customer Service: [custserv@vicorpower.com](mailto:custserv@vicorpower.com)

Technical Support: [apps@vicorpower.com](mailto:apps@vicorpower.com)