

Features

- +12V Bus Input
- 5-bit Programmable:
1.3V to 3.5V or
4.5V to 7.6V
- High Efficiency
- Differential Remote Sense
- 27-pin SIP Package
- Parallelable with PT7748
17A current booster



Description

The PT7720 series is a +12-V input, 17-A output, high-performance Integrated Switching Regulator (ISR), housed in a 27-pin SIP package. The 17A capability allows easy integration of the latest high-speed, low-voltage microprocessors and bus drivers into +12V power systems.

The output voltage is programmable using a 5-bit code. The output voltage range and code for the PT7721 is compatible with Intel's Pentium® II processor.

The PT7720 series has been designed to work in parallel with one or more of the PT7748 current boosters, allowing the output load current capacity to be increased in increments of 17A.

A differential remote sense is provided to compensate for voltage drop between the ISR to the load. A 1200µF of output capacitance is required for proper operation.

Ordering Information

- PT7721□** = 1.3 to 3.5 Volts
PT7722□ = 4.5 to 7.6 Volts
PT7748□ = 17-A Booster

Pin-Out Information

Pin	Function	Pin	Function
1	VID0	15	GND
2	VID1	16	GND
3	VID2	17	GND
4	VID3	18	GND
5	STBY #	19	GND
6	VID4	20	Vout
7	Vin	21	Vout
8	Vin	22	Vout
9	Vin	23	Vout
10	Vin	24	Vout
11	Vin	25	Vout
12	Sense Gnd	26	Sense Vout
13	GND	27	Sync Out
14	GND		

PT Series Suffix (PT1234 x)

Case/Pin Configuration	Order Suffix	Package Code *
Vertical	N	(EJE)
Horizontal	A	(EJF)
SMD	C	(EJG)

* Previously known as package styles 1000/1010. (Reference the applicable package code drawing for the dimensions and PC board layout)

For further information, see application notes.

Standard Application

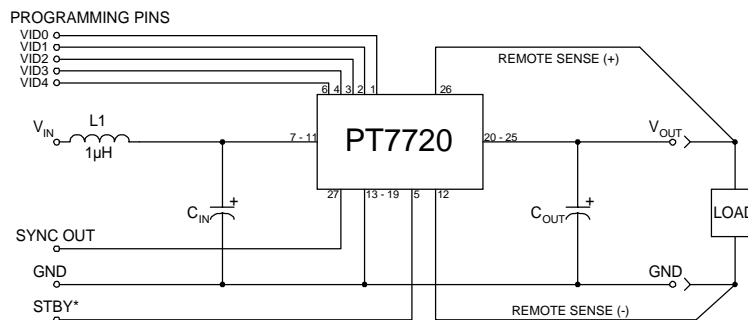

- C_{in} = Required 560µF electrolytic (See input filter note)
- C_{out} = Required 1200µF electrolytic
- L₁ = Optional 1µH input choke

PT7720 Series

17 A, 12-V Input "Big-Hammer II"
Programmable ISR

Programming Information

				PT7721		PT7722	
VID3	VID2	VID1	VID0	VID4=1 Vout	VID4=0 Vout	VID4=1 Vout	VID4=0 Vout
1	1	1	1	2.0V	1.30V	4.5V	6.1V
1	1	1	0	2.1V	1.35V	4.6V	6.2V
1	1	0	1	2.2V	1.40V	4.7V	6.3V
1	1	0	0	2.3V	1.45V	4.8V	6.4V
1	0	1	1	2.4V	1.50V	4.9V	6.5V
1	0	1	0	2.5V	1.55V	5.0V	6.6V
1	0	0	1	2.6V	1.60V	5.1V	6.7V
1	0	0	0	2.7V	1.65V	5.2V	6.8V
0	1	1	1	2.8V	1.70V	5.3V	6.9V
0	1	1	0	2.9V	1.75V	5.4V	7.0V
0	1	0	1	3.0V	1.80V	5.5V	7.1V
0	1	0	0	3.1V	1.85V	5.6V	7.2V
0	0	1	1	3.2V	1.90V	5.7V	7.3V
0	0	1	0	3.3V	1.95V	5.8V	7.4V
0	0	0	1	3.4V	2.00V	5.9V	7.5V
0	0	0	0	3.5V	2.05V	6.0V	7.6V

Logic 0 = Pin 12 potential (remote sense gnd)

Logic 1 = Open circuit (no pull-up resistors)

VID3 and VID4 may not be changed while the unit is operating.

Specifications (Unless otherwise stated, $T_a = 25^\circ\text{C}$, $V_{in} = 12\text{V}$, $C_{in} = 560\mu\text{F}$, $C_{out} = 1200\mu\text{F}$, and $I_o = I_{o,max}$)

Characteristics	Symbols	Conditions	PT7720 SERIES			Units	
			Min	Typ	Max		
Output Current	I_o	$T_a = +60^\circ\text{C}$, 200 LFM, pkg N, $T_a = +25^\circ\text{C}$, natural convection,	$V_o \leq 5\text{V}$ $V_o \leq 5\text{V}$	0.1 (1) 0.1 (1)	—	17 (2) 17 (2)	A
Output Power	P_o	$T_a = +60^\circ\text{C}$, 200 LFM, pkg N, $T_a = +25^\circ\text{C}$, natural convection,	$V_o \geq 5\text{V}$ $V_o \geq 5\text{V}$	—	—	85 85	W
Input Voltage Range	V_{in}	$0.1\text{A} \leq I_o \leq 17\text{A}$		11.0	—	14.0	V
Output Voltage Tolerance	ΔV_o	$0^\circ\text{C} \leq T_a \leq +60^\circ\text{C}$	(PT7721) (PT7722)	$V_o - 0.03$ —	— ± 1	$V_o + 0.03$ ± 2	V % V_o
Line Regulation	Reg_{line}	$11\text{V} \leq V_{in} \leq 14\text{V}$ (with remote sense)		—	± 5	± 10	mV
Load Regulation	Reg_{load}	$0.1 \leq I_o \leq 17\text{A}$ (with remote sense)		—	± 5	± 10	mV
V_o Ripple/Noise	V_n		(PT7721) (PT7722)	— —	50 100	— —	mVpp
Transient Response with $C_{out} = 1200\mu\text{F}$	t_{tr} V_{os}	I_o step between 7.5A and 15A V_o over/undershoot		— —	100 200	— —	μSec mV
Efficiency	η	$I_o = 10\text{A}$	$V_o = 5.0\text{V}$ $V_o = 3.3\text{V}$ $V_o = 2.5\text{V}$ $V_o = 1.5\text{V}$	— — — —	90 88 85 78	— — — —	%
Switching Frequency	f_s	$11\text{V} \leq V_{in} \leq 14\text{V}$ $0.1\text{A} \leq I_o \leq 17\text{A}$		300	350	400	kHz
Operating Temperature Range	T_a	—		0	—	+85 (3)	$^\circ\text{C}$
Storage Temperature	T_s	—		-40	—	+125	$^\circ\text{C}$
Mechanical Shock		Per Mil-STD-883D, Method 2002.3, 1 msec, Half Sine, mounted to a fixture		—	TBD	—	G's
Mechanical Vibration		Per Mil-STD-883D, Method 2007.2, 20-2000 Hz, Soldered in a PC board		—	TBD	—	G's
Weight	—		Vertical Horizontal	— —	53 66	— —	grams

Notes: (1) The ISR will operate down to no load with reduced specifications. Please note that this product is not short-circuit protected.

(2) The PT7720 series can be easily paralleled with one or more of the PT7748 Current Boosters to provide increased output current in increments of 17A.

(3) See Safe Operating Area curves or contact the factory for the appropriate derating.

Output Capacitors: The PT7720 series requires a minimum output capacitance of 1200 μF for proper operation. Do not use Oscon type capacitors. The maximum allowable output capacitance is $(57,000 \div V_{out})\mu\text{F}$, or 15,000 μF , whichever is less.

Input Filter: An input inductor is optional for most applications. The input inductor must be sized to handle 7ADC with a typical value of 1 μH . The input capacitance must be rated for a minimum of 4 Arms of ripple current when operated at maximum output current and maximum output voltage. Contact an applications specialist for input capacitor selection for applications at other output voltages and output currents.

17 A, 12-V Input "Big-Hammer II"
Programmable ISR

PT7721/PT7722 @ $V_{in} = 12V$ (See Note A)

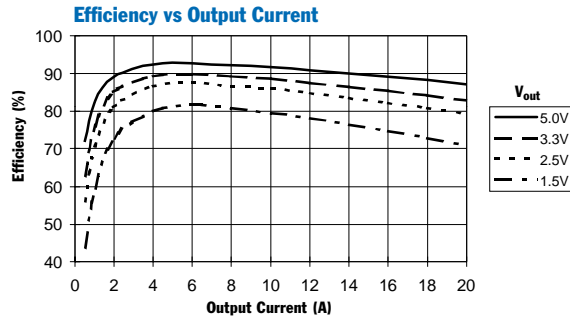

Safe Operating Area, $V_{in} = +12V$ (See Note B)

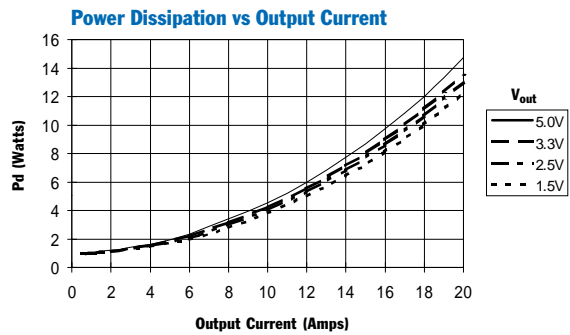
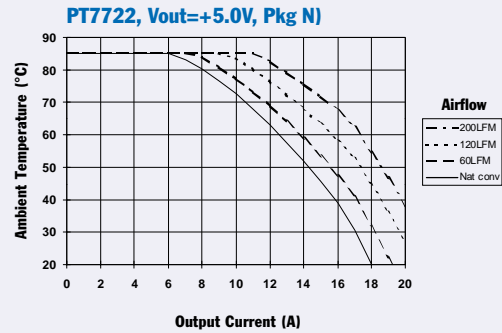
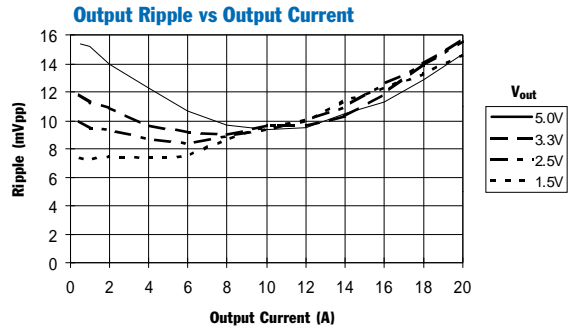
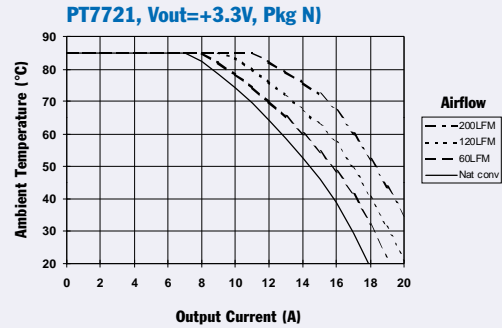

Note A: Characteristic data has been developed from actual products tested at 25°C. This data is considered typical data for the Converter.
Note B: SOA curves represent the conditions at which internal components are at or below the manufacturer's maximum operating temperatures

Using the PT7748 17-A Current Booster with the PT7720 Series Programmable ISRs

The PT7748 is a 17-A “Current Booster” module for the PT7720 series of regulators. The booster is controlled directly by the regulator, and effectively adds a parallel output stage. This allows the system to run synchronously, providing a low noise solution. Up to four booster modules can be connected to a single regulator. Each booster increases the available output current by 17A. Combinations of a regulator and booster modules can supply power for virtually any multi-processor application.

A current booster is not a stand-alone product, and can only operate with a regulator. It is housed in the same package as its compatible regulator, and shares the same mechanical outline. Except for an increase in output current, the overall performance of a PT7720 regulator/booster combination is identical to that of a stand-alone regulator. Refer to the appropriate data sheet for the performance specifications.

Notes:

1. Each booster requires the same amount of input and output capacitance as recommended for a stand-alone regulator. See the Standard Application schematic and

the respective input/output filter notes in the PT7720 product data sheet.

2. The 1- μ H filter choke located at the input of each regulator and booster module (L_{in}) is optional for most applications. If specified, each inductor must be sized to handle 7ADC at full output load.
3. The pin-out of the current booster modules include a number pins identified, “No Connect” (see Table 1). These pins are not connected internally to the module but must be soldered to a pad to preserve the unit’s mechanical integrity.
4. A similar PCB footprint and trace layout between the regulator and each booster will facilitate current sharing between all modules.

Table 1-1; PT7748 Pin-Out Information

Pin	Function	Pin	Function	Pin	Function
1	No Connect	10	V_{in}	19	GND
2	No Connect	11	V_{in}	20	V_{out}
3	No Connect	12	No Connect	21	V_{out}
4	No Connect	13	GND	22	V_{out}
5	No Connect	14	GND	23	V_{out}
6	No Connect	15	GND	24	V_{out}
7	V_{in}	16	GND	25	V_{out}
8	V_{in}	17	GND	26	No Connect
9	V_{in}	18	GND	27	Sync In

Figure 1-1; Current Booster Application Schematic

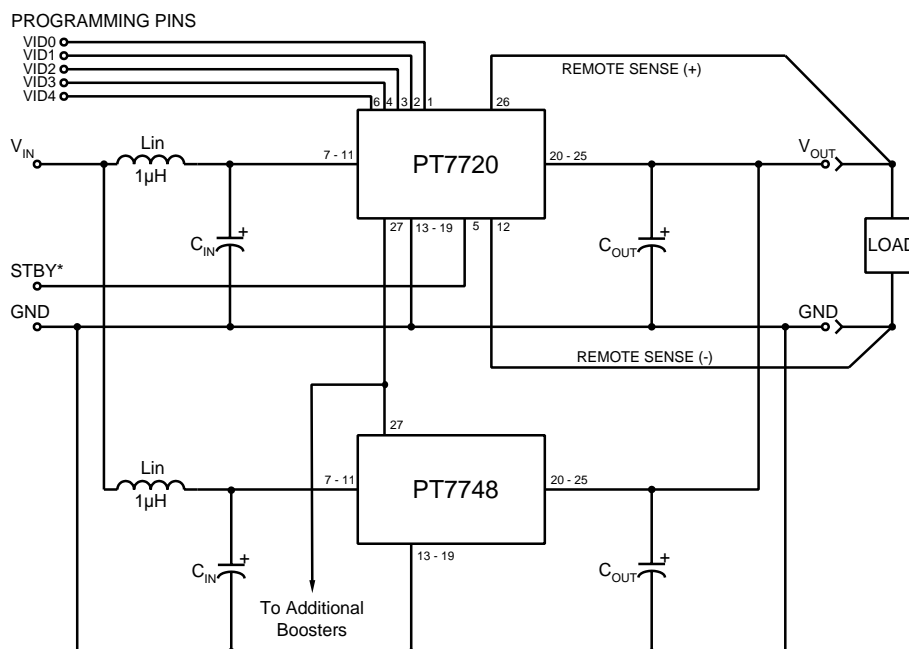

Pin-Coded Output Voltage Adjustment on the “Big Hammer II” Series ISRs

Power Trends PT7720 series ISRs incorporate pin-coded voltage control to adjust the output voltage. The control pins are identified VID0 - VID4 (pins 1, 2, 3, 4, & 6) respectively. When the control pins are left open-circuit, the ISR will regulate at its factory trimmed output voltage. Each pin is internally connected to a precision resistor, which when grounded changes the output voltage by a set amount. By selectively grounding VID0-VID4, the output voltage of each ISR in the PT7720 series ISRs can be programmed in incremental steps over its specified output voltage range. The output voltage ranges offered by these regulators provide a convenient method of voltage selection for many applications. In addition, the program code and output voltage range of the PT7721 model is compatible with the voltage ID specification defined by Intel Corporation for voltage regulator modules (VRMs) used to power Pentium® II microprocessors. Refer to Figure 2-1 below for the connection schematic, and the PT7720 Data Sheet for the appropriate programming code information.

Notes:

1. The programming convention is as follows:-
 - Logic 0: Connect to pin12 (Remote Sense Ground).
 - Logic 1: Open circuit/open drain (See notes 2, & 4)
2. Do not connect pull-up resistors to the voltage programming pins.
3. To minimize output voltage error, always use pin 12 (Sense Ground) as the logic “0” reference. While the regular

ground (pins 13-19) can also be used for programming, doing so will degrade the load regulation of the product.

4. If active devices are used to ground the voltage control pins, low-level open drain MOSFET devices should be used over bipolar transistors. The inherent $V_{ce(sat)}$ in bipolar devices introduces errors in the device’s internal divider network. Discrete transistors such as the BSS138, 2N7002, or the IRLML2402 are examples of appropriate devices.

Active Voltage Programming:

Special precautions should be taken when making changes to the voltage control program code while the unit is powered. It is highly recommended that the ISR be either powered down or held in standby. Changes made to the program code while V_{out} is enabled induces high current transients through the device. This is the result of the electrolytic output capacitors being either charged or discharged to the new output voltage set-point. The transient current can be minimized by making only incremental changes to the binary code, i.e. one LSB at a time. A minimum of 100 μ s settling time between each program state is also recommended. Making non-incremental changes to VID3 and VID4 with the output enabled is discouraged. If they are changed, the transients induced can overstress the device resulting in a permanent drop in efficiency. If the use of active devices prevents the program code being asserted prior to power-up, pull pin 5 (STBY) to the device GND during the period that the input voltage is applied to V_{in} . Releasing pin 5 will then allow the device output to execute a soft-start power-up to the programmed voltage.

Figure 2-1

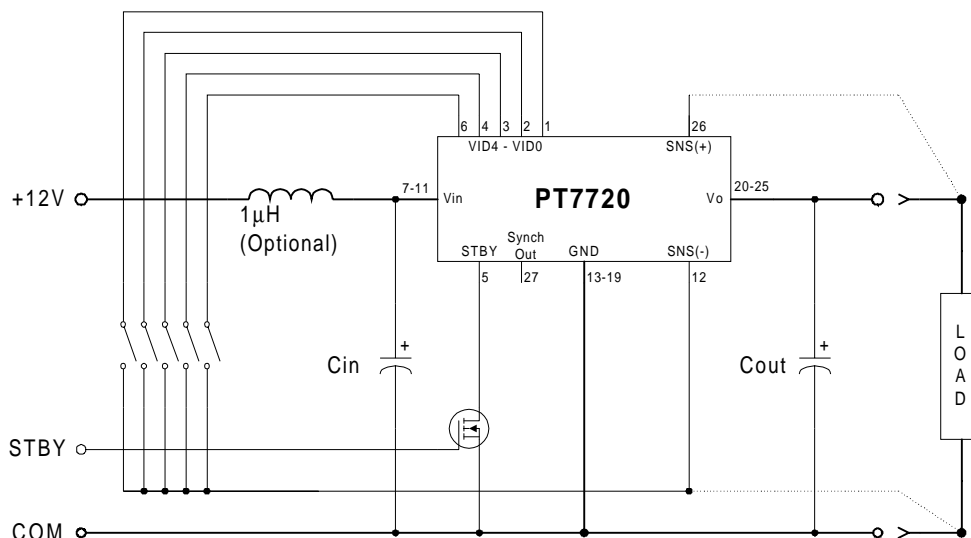

Using the Standby Function on the PT7720 “Big Hammer II” Programmable ISRs

For applications requiring output voltage On/Off control, the PT7720 “Big Hammer” ISRs incorporate a standby function. This feature may be used for power-up/shut-down sequencing, and wherever there is a requirement for the output status of the module to be controlled by external circuitry.

The standby function is provided by the *STBY** control, pin 5. If pin 5 is left open-circuit the regulator operates normally, providing a regulated output whenever a valid supply voltage is applied to V_{in} (pins 7-11) with respect to GND (pins 13-19). Connecting pin 5 to ground¹ will set the regulator output to zero volts². This places the regulator in standby mode, and reduces the input current to typically 30mA (50mA max). If a ground signal is applied to pin 5 prior to power-up, the regulator output will be held at zero volts during the period that input power is applied.

The standby input must be controlled with an open-collector (or open-drain) discrete transistor (See Figure 3-1). Table 3-1 gives the threshold requirements.

Table 3-1 Inhibit Control Threshold¹

Parameter	Min	Max
Disable (V_{IL})	-0.1V	0.3V

Notes:

1. The Standby input on the PT7720 regulator series must be controlled using an open-collector (or open-drain) discrete transistor. *Do Not* use a pull-up resistor. The control input has an open-circuit voltage of about 1.5Vdc. To set the regulator output to zero, the control pin must be “pulled” to less than 0.3Vdc with a low-level 0.1mA sink to ground.
2. When placed in the standby mode, the regulator output discharges the output capacitance with a low impedance to ground. If an external voltage is applied to the output, it will sink current and possibly over-stress the part.
3. The turn-off time of Q_1 , or rise time of the standby input is not critical on the PT7720 series. Turning Q_1 off slowly, over periods up to 100ms, will not affect regulator operation. However, a slow turn-off time will increase both the initial delay and rise-time of the output voltage.

Figure 3-1

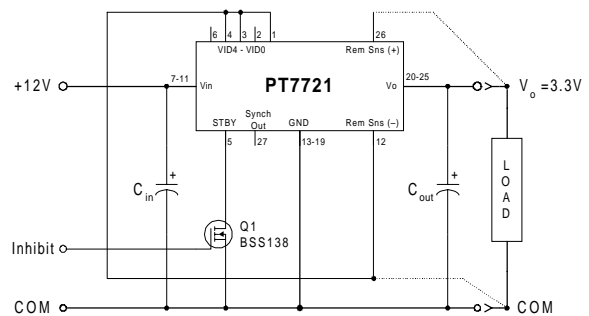

Turn-On Time: Turning Q_1 in Figure 3-1 off, removes the low-voltage signal at pin 5 and enables the output. Following a brief delay of 5-15ms, the output voltage of the PT7720 series regulators rise to full regulation within 20ms³. Figure 3-2 shows the typical output voltage waveform of a PT7721, following the prompt turn-off of Q_1 at time $t=0$ secs. The output voltage in Figure 3-1 is set to 3.3V by connecting VID0 (pin 1), VID2 (pin 3), and VID3 (pin 4) to the Sense Gnd (pin 12)*. The waveform in Figure 3-2 was measured with a 12-V input source voltage, and 15-A resistive load.

Figure 3-2

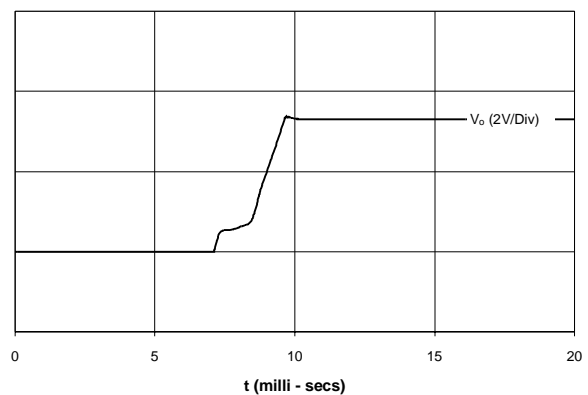

* Consult the data sheet for details on other VID codes.

IMPORTANT NOTICE

Texas Instruments Incorporated and its subsidiaries (TI) reserve the right to make corrections, modifications, enhancements, improvements, and other changes to its products and services at any time and to discontinue any product or service without notice. Customers should obtain the latest relevant information before placing orders and should verify that such information is current and complete. All products are sold subject to TI's terms and conditions of sale supplied at the time of order acknowledgment.

TI warrants performance of its hardware products to the specifications applicable at the time of sale in accordance with TI's standard warranty. Testing and other quality control techniques are used to the extent TI deems necessary to support this warranty. Except where mandated by government requirements, testing of all parameters of each product is not necessarily performed.

TI assumes no liability for applications assistance or customer product design. Customers are responsible for their products and applications using TI components. To minimize the risks associated with customer products and applications, customers should provide adequate design and operating safeguards.

TI does not warrant or represent that any license, either express or implied, is granted under any TI patent right, copyright, mask work right, or other TI intellectual property right relating to any combination, machine, or process in which TI products or services are used. Information published by TI regarding third-party products or services does not constitute a license from TI to use such products or services or a warranty or endorsement thereof. Use of such information may require a license from a third party under the patents or other intellectual property of the third party, or a license from TI under the patents or other intellectual property of TI.

Reproduction of information in TI data books or data sheets is permissible only if reproduction is without alteration and is accompanied by all associated warranties, conditions, limitations, and notices. Reproduction of this information with alteration is an unfair and deceptive business practice. TI is not responsible or liable for such altered documentation.

Resale of TI products or services with statements different from or beyond the parameters stated by TI for that product or service voids all express and any implied warranties for the associated TI product or service and is an unfair and deceptive business practice. TI is not responsible or liable for any such statements.

Mailing Address:

Texas Instruments
Post Office Box 655303
Dallas, Texas 75265