

MAX15008/MAX15010

300mA LDO Voltage Regulators with Tracker Output and Overvoltage Protector

General Description

The MAX15008 features a 300mA LDO regulator, a voltage tracker, and an overvoltage protection (OVP) controller to protect downstream circuits from high-voltage transients. The MAX15010 includes only the 300mA LDO voltage regulator and voltage tracker. Both devices operate over a wide 5V to 40V supply voltage range and are able to withstand load-dump transients up to 45V. The MAX15008/MAX15010 feature short-circuit and thermal-shutdown protection.

The 300mA LDO regulator consumes less than 67 μ A quiescent current at light loads and is well suited to power always-on circuits during “key off” conditions. The LDO features independent enable and hold inputs, as well as a microprocessor (μ P) reset output with an adjustable reset timeout period.

The voltage tracker accurately (± 3 mV) tracks a voltage applied to its input from either the LDO output or an external source. It can supply up to 50mA of current to a remote sensor, allowing for precise ratiometric tracking in industrial applications. A separate enable input turns the tracker on or off, reducing supply current when the tracker is unused. The voltage tracker also features protection against battery reversal, an output short circuit to the battery, or an output voltage excursion below ground potential to as much as -5V.

The MAX15008 OVP controller operates with an external enhancement mode n-channel MOSFET. While the monitored voltage remains below the adjustable threshold, the MOSFET stays on. When the monitored voltage exceeds the OVP threshold, the OVP controller quickly turns off the external MOSFET. The OVP controller is configurable as a load-disconnect switch or a voltage limiter.

The MAX15008/MAX15010 are available in a thermally enhanced, 32-pin (5mm x 5mm) TQFN package and are fully specified over the -40°C to +125°C operating temperature range.

Applications

- Multimedia Power Supply

Typical Operating Circuits appear at end of data sheet.

Features

- 300mA LDO Regulator, Voltage Tracker, and OVP Controller (MAX15008)
- 300mA LDO Regulator and Voltage Tracker (MAX15010)
- 50mA Voltage Tracker with ± 3 mV Tracking Accuracy
- 5V to 40V Wide Operating Supply Voltage Range
- 67 μ A Quiescent Current LDO Regulator
- OVP Controller Disconnects or Limits Output from Battery Overvoltage Conditions (MAX15008)
- LDO Regulator with Enable, Hold, and Reset Features

Ordering Information

PART	TEMP RANGE	PIN-PACKAGE
MAX15008ATJ+	-40°C to +125°C	32 TQFN-EP*
MAX15010ATJ+	-40°C to +125°C	32 TQFN-EP*

+Denotes a lead(Pb)-free/RoHS-compliant package.

*EP = Exposed pad.

Selector Guide

PART	LDO	TRACKER	OVP CONTROLLER
MAX15008	✓	✓	✓
MAX15010	✓	✓	—

Pin Configurations

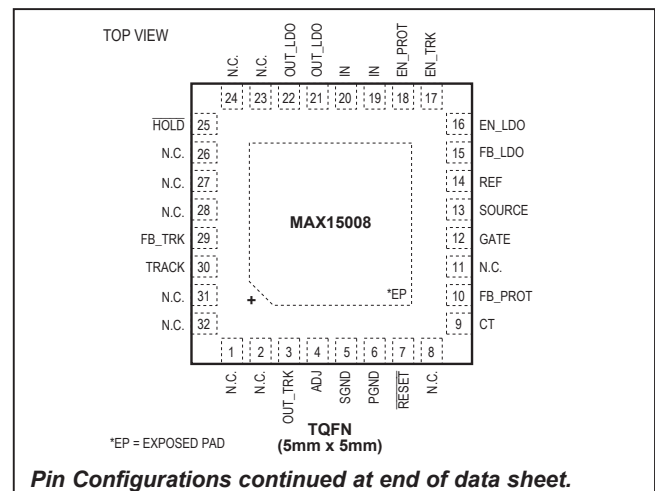

Absolute Maximum Ratings

(All pins referenced to SGND, unless otherwise noted.)

IN, GATE	-0.3V to +45V
TRACK	-20V to +45V
EN_LDO, EN_PROT, EN_TRK	-0.3V to (V _{IN} + 0.3V)
SOURCE	-0.3V to (V _{IN} + 0.3V)
TRACK to OUT_TRK	-40V to +40V
OUT_TRK, FB_TRK, ADJ	-5V to +45V
OUT_LDO, FB_LDO, FB_PROT, RESET	-0.3V to +12V
GATE to SOURCE	-0.3V to +12V
HOLD	-0.3V to (V _{OUT_LDO} + 0.3V)
REF to SGND	-0.3V to +6V
CT to SGND	-0.3V to +12V
SGND to PGND	-0.3V to +0.3V

IN, OUT_LDO Current	700mA
TRACK, OUT_TRK Current	350mA
Current Sink/Source (all remaining pins)	50mA
Continuous Power Dissipation (T _A = +70°C)	
32-Pin TQFN (derate 34.5mW/°C above +70°C)	2.7W*
Thermal Resistance	
θ _{JA}	29.0°C/W
θ _{JC}	1.7°C/W
Operating Temperature Range	-40°C to +125°C
Junction Temperature	+150°C
Storage Temperature Range	-60°C to +150°C
Lead Temperature (soldering, 10s)	+300°C

*As per JEDEC51 Standard, Multilayer Board (PCB).

Stresses beyond those listed under "Absolute Maximum Ratings" may cause permanent damage to the device. These are stress ratings only, and functional operation of the device at these or any other conditions beyond those indicated in the operational sections of the specifications is not implied. Exposure to absolute maximum rating conditions for extended periods may affect device reliability.

Electrical Characteristics

(V_{IN} = V_{TRACK} = +14V, V_{SGND} = V_{PGND} = 0V, C_{GATE} = 6000pF, C_{IN} = 10µF (ESR ≤ 1.5Ω), C_{OUT_LDO} = 22µF (ceramic), C_{TRACK} = 3.3µF (ceramic) (ESR ≤ 1.5Ω), C_{OUT_TRK} = 10µF (ESR ≤ 1.5Ω), C_{REF} = 1000pF, V_{OUT_LDO} = 5V, T_A = T_J = -40°C to +125°C, unless otherwise noted. Typical values are at T_A = +25°C.) (Note 1)

PARAMETER	SYMBOL	CONDITIONS	MIN	TYP	MAX	UNITS
Supply Voltage Range	V _{IN}		5		40	V
Supply Current	I _{IN}	MAX15008 EN_LDO = IN, EN_TRK = EN_PROT = 0V, I _{OUT_LDO} = 0µA, LDO on, tracker off, protector off, measured from SGND		67	85	µA
		MAX15008 EN_LDO = EN_TRK = IN, EN_PROT = 0V, LDO on, I _{OUT_LDO} = 100µA, tracker on, I _{OUT_TRK} = 0µA, protector off, V _{FB_TRK} = V _{OUT_TRK} ; V _{ADJ} = V _{REF} , measured from SGND		120	180	
		MAX15008 EN_LDO = EN_TRK = EN_PROT = IN, LDO on, I _{OUT_LDO} = 100µA, tracker on, I _{OUT_TRK} = 0µA, protector on, V _{FB_TRK} = V _{OUT_TRK} ; V _{ADJ} = V _{REF} , measured from SGND		190	280	
		MAX15010 EN_LDO = EN_TRK = IN, LDO on, I _{OUT_LDO} = 100µA, tracker on, I _{OUT_TRK} = 0µA, measured from SGND		115	160	
Shutdown Supply Current	I _{SHDN}	EN_LDO = EN_PROT = EN_TRK = 0V, measured from SGND	T _A = -40°C to +85°C	16	30	µA
			T _A = -40°C to +125°C		40	

Electrical Characteristics (continued)

($V_{IN} = V_{TRACK} = +14V$, $V_{SGND} = V_{PGND} = 0V$, $C_{GATE} = 6000pF$, $C_{IN} = 10\mu F$ (ESR $\leq 1.5\Omega$), $C_{OUT_LDO} = 22\mu F$ (ceramic), $C_{TRACK} = 3.3\mu F$ (ceramic) (ESR $\leq 1.5\Omega$), $C_{OUT_TRK} = 10\mu F$ (ESR $\leq 1.5\Omega$), $C_{REF} = 1000pF$, $V_{OUT_LDO} = 5V$, $T_A = T_J = -40^\circ C$ to $+125^\circ C$, unless otherwise noted. Typical values are at $T_A = +25^\circ C$.) (Note 1)

PARAMETER	SYMBOL	CONDITIONS	MIN	TYP	MAX	UNITS
IN Undervoltage Lockout	V_{UVLO}	V_{IN} falling, GATE disabled	4.10	4.27	4.45	V
IN Undervoltage Lockout Hysteresis	V_{UVLO_HYST}			260		mV
Internal Voltage Reference	REF	$I_{REF} = 0\mu A$	1.21	1.235	1.26	V
Internal Voltage Reference Maximum Current	I_{REF}	$\Delta V_{REF} = \pm 200mV$	-6		+6	μA
Thermal-Shutdown Temperature	T_{SHDN}			+160		$^\circ C$
Thermal Hysteresis	T_{HYST}			20		$^\circ C$
LDO						
Output Voltage	V_{OUT_LDO}	$I_{LOAD} = 1mA$, $FB_LDO = SGND$	4.92	5	5.09	V
		$I_{LOAD} = 300mA$, $V_{IN} = 8V$, $FB_LDO = SGND$	4.80	5	5.11	
FB_LDO Set-Point Voltage	V_{FB_LDO}	With respect to SGND, $I_{LOAD} = 1mA$, $V_{OUT_LDO} = 5V$ (adjustable output option)	1.21	1.235	1.26	V
Dual Mode™ FB_LDO Threshold	$V_{FB_LDO_TH}$	FB_LDO rising		0.125		V
		FB_LDO falling		0.064		
FB_LDO Input Current	I_{FB_LDO}	$V_{FB_LDO} = 1V$	-100		+100	nA
LDO Output Voltage Range	V_{LDO_ADJ}	Adjustable output option (Note 2)	1.8		11.0	V
LDO Dropout Voltage (Note 3)	V_{DO}	$I_{LOAD} = 300mA$		775	1500	mV
		$I_{LOAD} = 200mA$		520	1000	
LDO Output Current	I_{OUT_LDO}	(Note 4)	300			mA
LDO Output Current Limit	I_{LIM_LDO}	$OUT_LDO = GND$, $V_{IN} = 6V$	330	500	700	mA
OUT_LDO Line Regulation	$\frac{\Delta V_{OUT}}{\Delta V_{IN}}$	$6V \leq V_{IN} \leq 40V$, $I_{LOAD} = 1mA$, $V_{OUT_LDO} = 5V$		0.03	0.2	mV/V
		$6V \leq V_{IN} \leq 40V$, $I_{LOAD} = 1mA$, $V_{OUT_LDO} = 3.3V$		0.03	0.1	
		$6V \leq V_{IN} \leq 40V$, $I_{LOAD} = 20mA$, $FB_LDO = SGND$, $V_{OUT_LDO} = 5V$		0.27	1	
		$6V \leq V_{IN} \leq 40V$, $I_{LOAD} = 20mA$, $V_{OUT_LDO} = 3.3V$		0.27	0.5	
OUT_LDO Load Regulation	$\frac{\Delta V_{OUT}}{\Delta I_{OUT}}$	$1mA$ to $300mA$, $V_{IN} = 8V$, $FB_LDO = SGND$, $V_{OUT_LDO} = 5V$		0.054	0.15	mV/mA
		$1mA$ to $300mA$, $V_{IN} = 6.3V$, $V_{OUT_LDO} = 3.3V$		0.038	0.1	
OUT_LDO Power-Supply Rejection Ratio	PSRR	$I_{LOAD} = 10mA$, $f = 100Hz$, $500mV_{P-P}$, $C_{OUT_LDO} = 22\mu F$, $V_{OUT_LDO} = 5V$		60		dB

Dual Mode is a trademark of Maxim Integrated Products, Inc.

Electrical Characteristics (continued)

($V_{IN} = V_{TRACK} = +14V$, $V_{SGND} = V_{PGND} = 0V$, $C_{GATE} = 6000pF$, $C_{IN} = 10\mu F$ (ESR $\leq 1.5\Omega$), $C_{OUT_LDO} = 22\mu F$ (ceramic), $C_{TRACK} = 3.3\mu F$ (ceramic) (ESR $\leq 1.5\Omega$), $C_{OUT_TRK} = 10\mu F$ (ESR $\leq 1.5\Omega$), $C_{REF} = 1000pF$, $V_{OUT_LDO} = 5V$, $T_A = T_J = -40^\circ C$ to $+125^\circ C$, unless otherwise noted. Typical values are at $T_A = +25^\circ C$.) (Note 1)

PARAMETER	SYMBOL	CONDITIONS	MIN	TYP	MAX	UNITS
OUT_LDO Startup-Delay Time	$t_{STARTUP_DELAY}$	$I_{OUT_LDO} = 0mA$, from EN_LDO rising to 10% of V_{OUT_LDO} (nominal), $FB_LDO = SGND$		30		μs
OUT_LDO Overvoltage-Protection Threshold	V_{OV_TH}	1mA sink from OUT_LDO		105	110	% V_{OUT_LDO}
OUT_LDO Overvoltage-Protection Sink Current	I_{OV}	$V_{OUT_LDO} = V_{OUT}$ (nominal) x 1.15	8	19		mA
ENABLE/HOLD INPUTS						
EN_LDO, EN_PROT, EN_TRK Input Threshold Voltage	V_{IH}		2			V
	V_{IL}				0.7	
EN_LDO, EN_PROT, EN_TRK Input Pulldown Current	I_{EN_PD}	EN_ is internally pulled low to SGND		1		μA
\overline{HOLD} Input Threshold Voltage	V_{IH}		1.4			V
	V_{IL}				0.4	
\overline{HOLD} Input Pullup	$I_{\overline{HOLD_PU}}$	\overline{HOLD} is internally pulled high to OUT_LDO		0.6		μA
RESET						
\overline{RESET} Voltage-Threshold High	$V_{\overline{RESET_H}}$	\overline{RESET} goes HIGH when rising V_{OUT_LDO} crosses this threshold, $FB_LDO = SGND$	90.0	92.5	95.0	% V_{OUT_LDO}
		\overline{RESET} goes HIGH when rising V_{OUT_LDO} crosses this threshold	90.0	92.5	95.0	% V_{FB_LDO}
\overline{RESET} Voltage-Threshold Low	$V_{\overline{RESET_L}}$	\overline{RESET} goes LOW when falling V_{OUT_LDO} crosses this threshold, $FB_LDO = SGND$	88	90	92	% V_{OUT_LDO}
		\overline{RESET} goes LOW when falling V_{OUT_LDO} crosses this threshold	88	90	92	% V_{FB_LDO}
V_{OUT_LDO} -to- \overline{RESET} Delay	$t_{\overline{RESET_FALL}}$	V_{OUT_LDO} falling, 0.1V/ μs		19		μs
CT Ramp Current	I_{CT}	$V_{CT} = 0V$	1.50	2.0	2.35	μA
CT Ramp Threshold	V_{CT_TH}	V_{CT} rising	1.19	1.235	1.27	V
\overline{RESET} Output-Voltage Low	V_{OL}	$I_{SINK} = 1mA$, output asserted			0.1	V
\overline{RESET} Open-Drain Leakage Current	I_{LEAK_RESET}	Output not asserted			150	nA
LOAD DUMP PROTECTOR (MAX15008 only)						
FB_PROT Threshold Voltage	V_{TH_PROT}	FB_PROT rising	1.20	1.235	1.27	V
FB_PROT Threshold Hysteresis	V_{HYST}			4		% V_{TH_PROT}
FB_PROT Input Current	I_{FB_PROT}	$V_{FB_PROT} = 1.4V$	-100		+100	nA

Electrical Characteristics (continued)

($V_{IN} = V_{TRACK} = +14V$, $V_{SGND} = V_{PGND} = 0V$, $C_{GATE} = 6000pF$, $C_{IN} = 10\mu F$ (ESR $\leq 1.5\Omega$), $C_{OUT_LDO} = 22\mu F$ (ceramic), $C_{TRACK} = 3.3\mu F$ (ceramic) (ESR $\leq 1.5\Omega$), $C_{OUT_TRK} = 10\mu F$ (ESR $\leq 1.5\Omega$), $C_{REF} = 1000pF$, $V_{OUT_LDO} = 5V$, $T_A = T_J = -40^\circ C$ to $+125^\circ C$, unless otherwise noted. Typical values are at $T_A = +25^\circ C$.) (Note 1)

PARAMETER	SYMBOL	CONDITIONS	MIN	TYP	MAX	UNITS
Startup Response Time	t_{START}	EN_PROT rising, EN_LDO = IN, to $V_{GATE} = 0.5V$		20		μs
GATE Rise Time	t_{GATE}	GATE rising to +8V, $V_{SOURCE} = 0V$		1		ms
FB_PROT to GATE Turn-Off Propagation Delay	t_{OV}	FB_PROT step from $V_{TH_PROT} - 250mV$ to $V_{TH_PROT} + 250mV$			0.6	μs
GATE Output High Voltage	V_{GATE}	$V_{SOURCE} = V_{IN} = 5.5V$, R_{GATE} to IN = $1M\Omega$	IN + 3.2	IN + 3.5	IN + 3.8	V
		$V_{SOURCE} = V_{IN}$; $V_{IN} \geq 14V$, R_{GATE} to IN = $1M\Omega$	IN + 7.0	IN + 8.1	IN + 9.5	
GATE Output Pulldown Current	I_{GATEPD}	$V_{GATE} = 5V$, $V_{EN_PROT} = 0V$		63	100	mA
GATE Charge-Pump Current	I_{GATE}	GATE = SGND		45		μA
GATE-to-SOURCE Clamp Voltage	V_{CLMP}		12	16	18	V
TRACKER						
Tracker Supply Voltage Range	V_{TRACK}		5		40	V
ADJ, FB_TRK Input Voltage	V_{ADJ}, V_{FB_TRK}		1.1		TRACK -0.5	V
Tracker Output Common-Mode Range	V_{CM}		1.1		TRACK -0.5	V
Tracking Accuracy Over Line	ΔV_{Q_LINE}	$I_{OUT_LDO} = 20mA$, $V_{FB_TRK} = V_{OUT_TRK} = 5V$, $V_{TRACK} = 6V$ to $28V$, $\Delta V_Q = V_{FB_TRK} - V_{ADJ}$	-3		+3	mV
Tracking Accuracy Over Load	ΔV_{Q_LOAD}	$V_{TRACK} = 6V$, $0.1mA \leq I_{OUT_TRK} \leq 50mA$, $V_{ADJ} = V_{OUT_TRK} = 5V$, $\Delta V_Q = V_{FB_TRK} - V_{ADJ}$	-3		+3	mV
ADJ, FB_TRK Input Current	I_{FB_TRK}, I_{ADJ}	$V_{FB_TRK} = V_{ADJ} = 5V$		0.03	0.2	μA
Dropout Voltage	V_{DO}	$V_{OUT_TRK} = 5V$, $I_{OUT_TRK} = 50mA$		0.28	0.5	V
Tracker Output Current	I_{OUT_TRK}	$V_{ADJ} = V_{OUT_TRK} = 5V$	50			mA
Output Current Limit	$I_{OUT_TRK_LIM}$	$V_{OUT_TRK} = 0V$	85	100	115	mA
Current Consumption	I_Q	$I_Q = I_{TRACK} - I_{OUT_TRK}$, $I_{OUT_TRK} = 50mA$, $V_{ADJ} = V_{FB_TRK} = 5V$, EN_LDO = EN_PROT = SGND, EN_TRK = IN		2.7	6	mA
OUT_TRK Power-Supply Rejection Ratio	PSRR	$I_{OUT_LDO} = 10mA$, $f = 100Hz$, $500mV_{P-P}$, $V_{OUT_TRK} = V_{FB_TRK}$, $V_{ADJ} = 5V$		60		dB
OUT_TRK Reverse Current	$I_{OUT_TRK_REVERSE}$	$V_{TRACK} = 14V$, $V_{OUT_TRK} = V_{FB_TRK} = 40V$, $V_{ADJ} = 5V$		10		μA

Note 1: Limits to $-40^\circ C$ are guaranteed by design.

Note 2: 1.8V is the minimum limit for proper HOLD functionality.

Note 3: Dropout is defined as $V_{IN} - V_{OUT_LDO}$ when V_{OUT_LDO} is 98% of the value of V_{OUT_LDO} for $V_{IN} = V_{OUT_LDO} + 1.5V$.

Note 4: Maximum output current may be limited by the power dissipation of the package.

Typical Operating Characteristics

(VIN = VEN_ = +14V, CIN = 10μF, COUT_LDO = 22μF, CTRACK = COUT_TRK = 10μF, VOUT_LDO = 5V, FB_LDO = SGND, TA = +25°C, unless otherwise specified.)

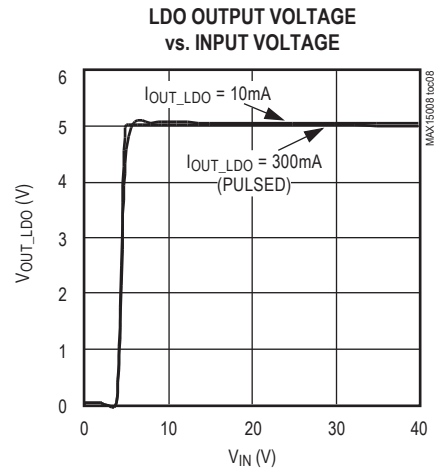
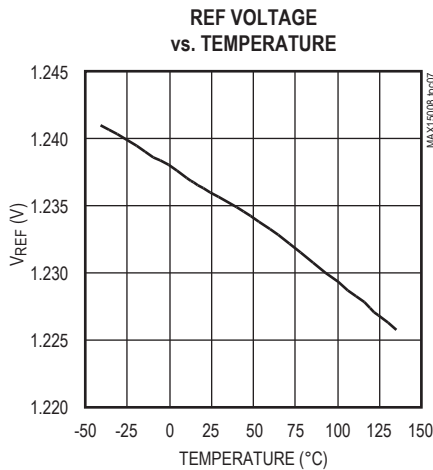
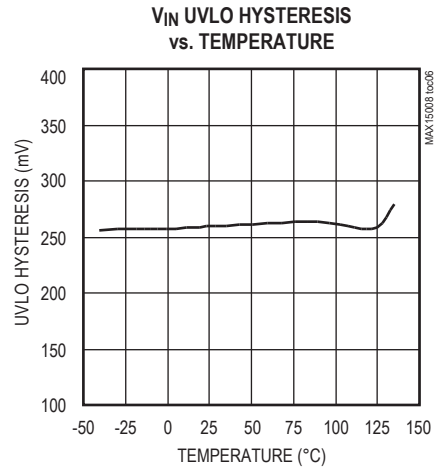
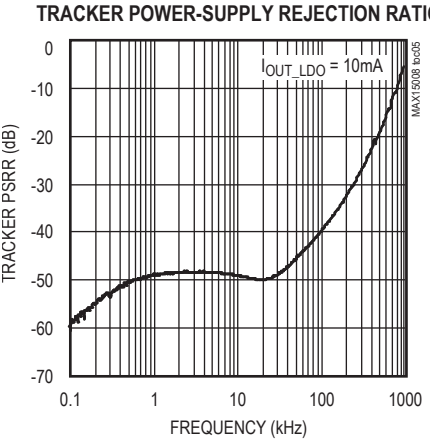
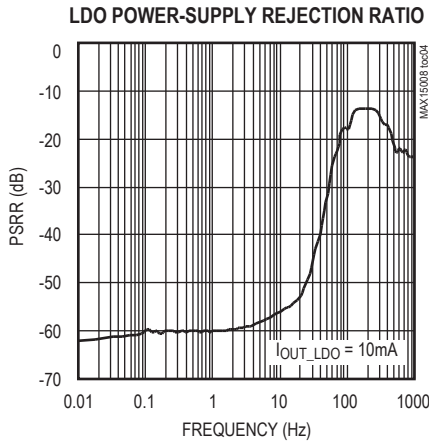
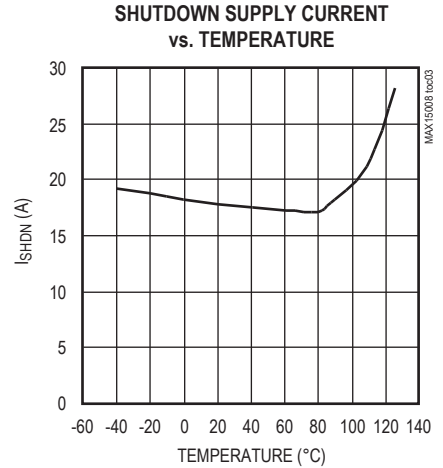
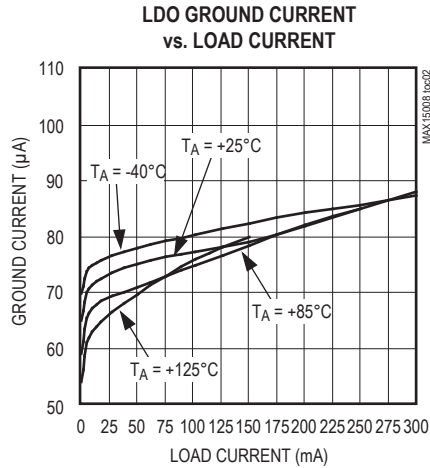
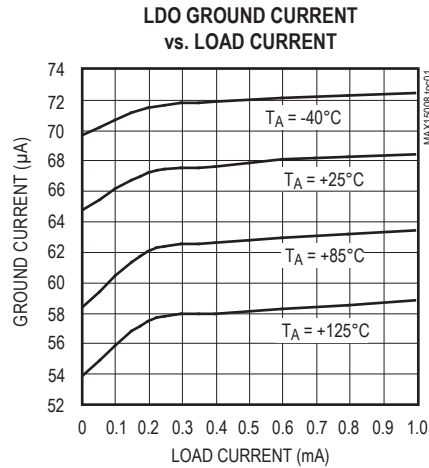

Typical Operating Characteristics (continued)

($V_{IN} = V_{EN_} = +14V$, $C_{IN} = 10\mu F$, $C_{OUT_LDO} = 22\mu F$, $C_{TRACK} = C_{OUT_TRK} = 10\mu F$, $V_{OUT_LDO} = 5V$, $FB_LDO = SGND$, $T_A = +25^\circ C$, unless otherwise specified.)

LDO LOAD-TRANSIENT RESPONSE

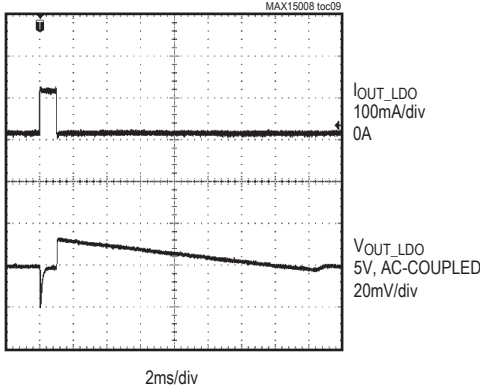

LDO LOAD-TRANSIENT RESPONSE

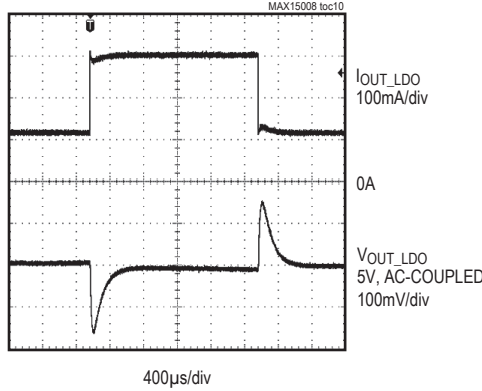

LDO OUTPUT VOLTAGE vs. TEMPERATURE

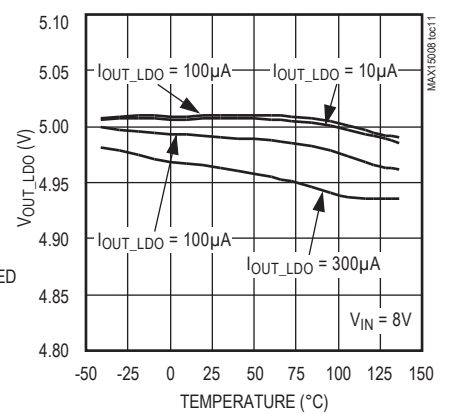

TRACKER LOAD-TRANSIENT RESPONSE

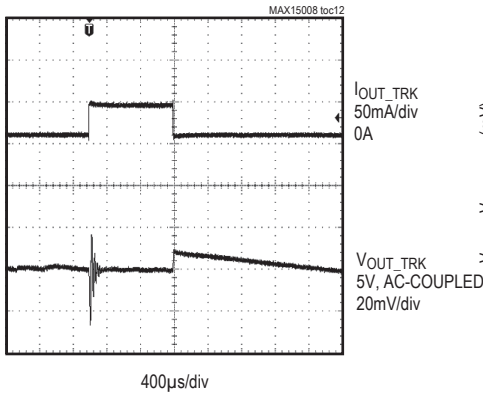

TRACKER ACCURACY vs. LOAD CURRENT

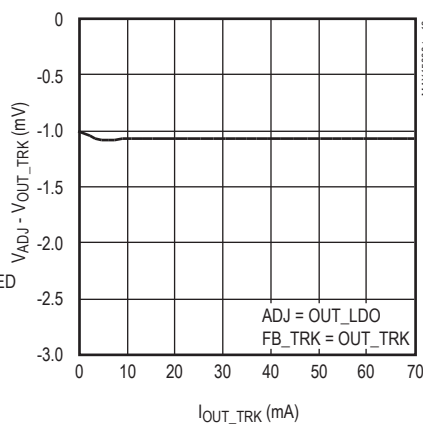

TRACKER ACCURACY ($V_{FB_TRK} = V_{ADJ}$) vs. TEMPERATURE

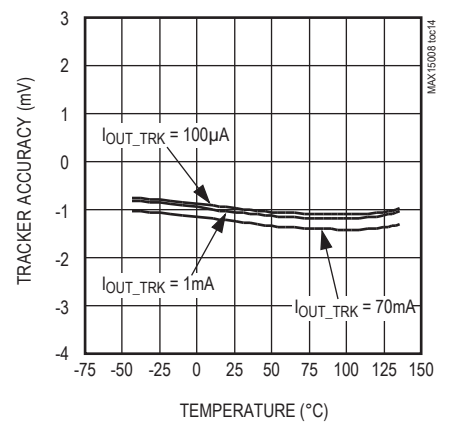

LINE-TRANSIENT RESPONSE

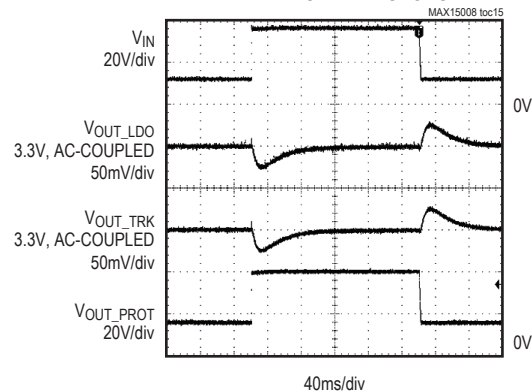

LINE-TRANSIENT RESPONSE

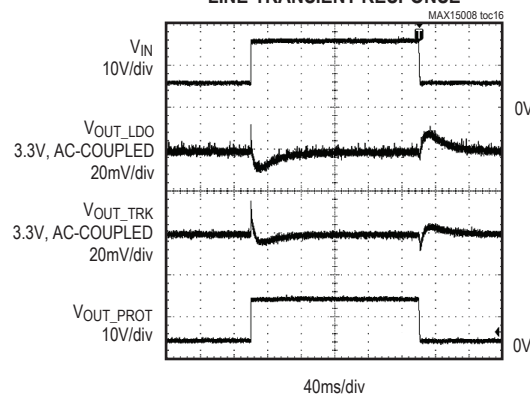

Typical Operating Characteristics (continued)

($V_{IN} = V_{EN_} = +14V$, $C_{IN} = 10\mu F$, $C_{OUT_LDO} = 22\mu F$, $C_{TRACK} = C_{OUT_TRK} = 10\mu F$, $V_{OUT_LDO} = 5V$, $FB_LDO = SGND$, $T_A = +25^\circ C$, unless otherwise specified.)

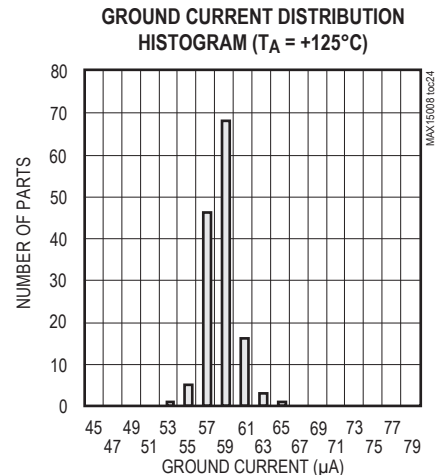
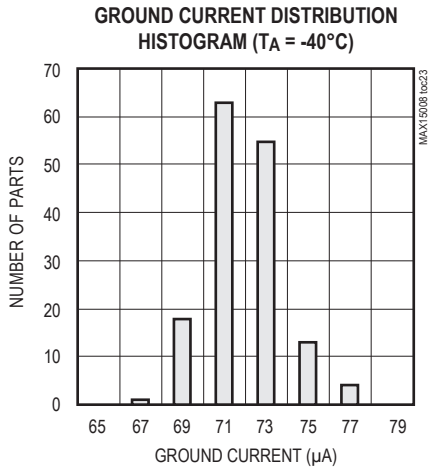
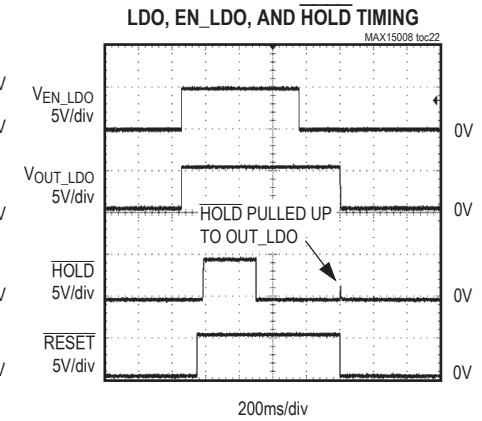
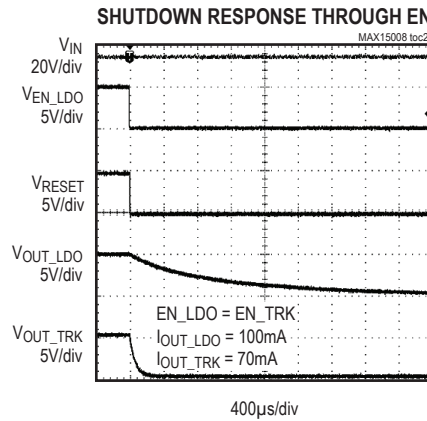
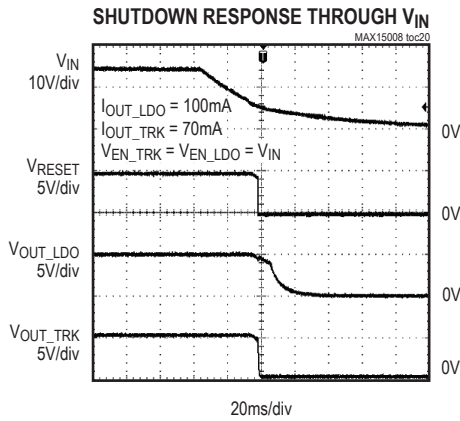
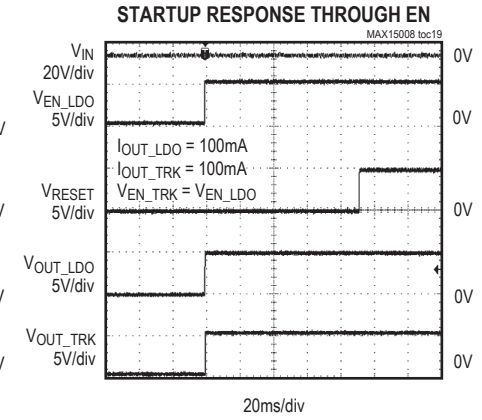
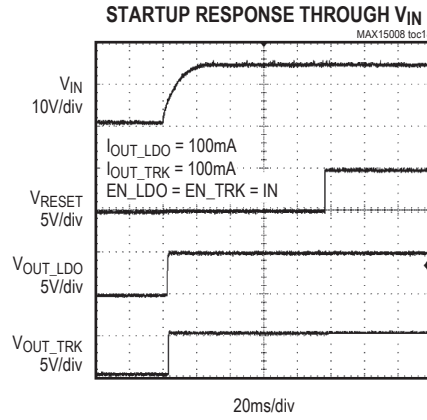
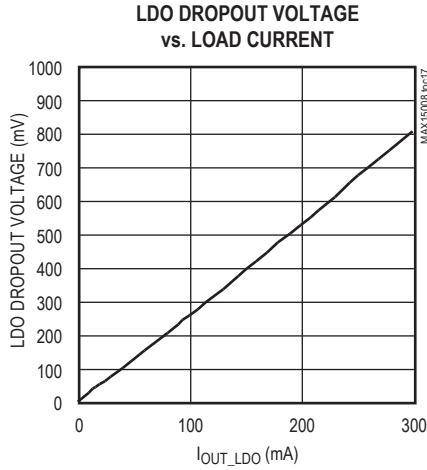

Typical Operating Characteristics (continued)

($V_{IN} = V_{EN_} = +14V$, $C_{IN} = 10\mu F$, $C_{OUT_LDO} = 22\mu F$, $C_{TRACK} = C_{OUT_TRK} = 10\mu F$, $V_{OUT_LDO} = 5V$, $FB_LDO = SGND$, $T_A = +25^\circ C$, unless otherwise specified.)

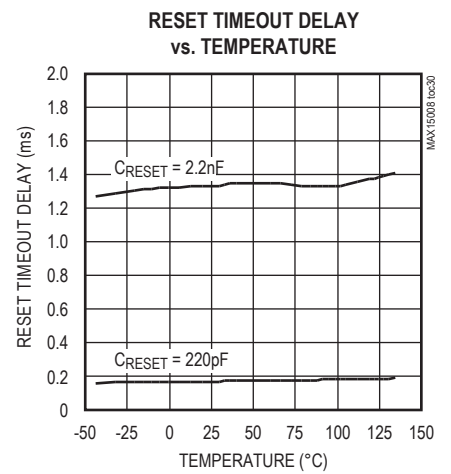
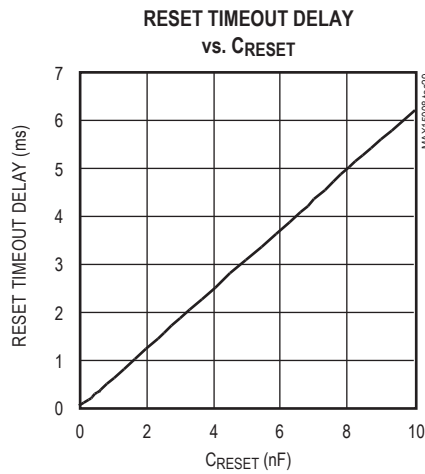
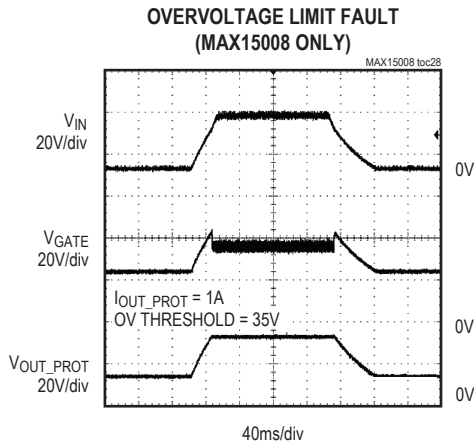
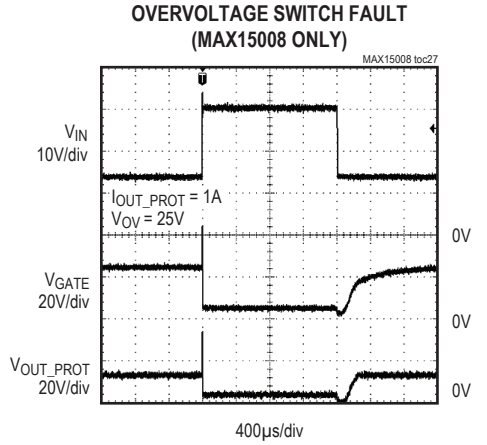
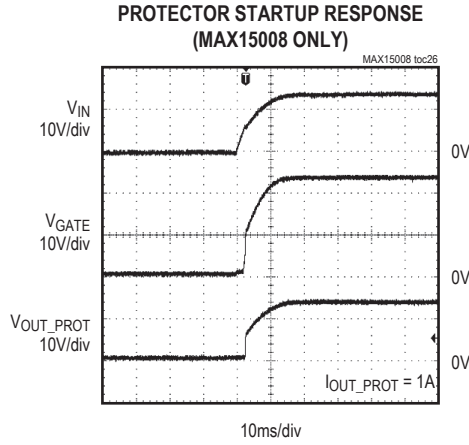
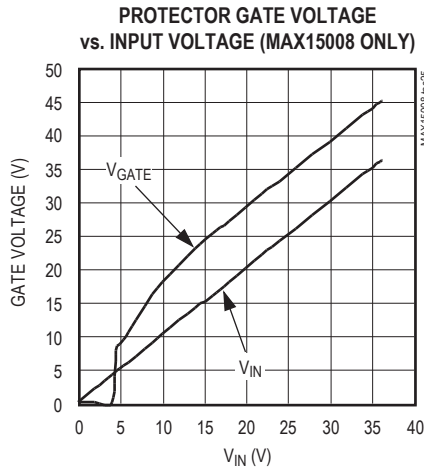

Pin Description

PIN		NAME	FUNCTION
MAX15008	MAX15010		
1, 2, 8, 11, 23, 24, 26–28, 31, 32	1, 2, 8, 10–13, 18, 23, 24, 26, 27, 28, 31, 32	N.C.	No Connection. Not internally connected.
3	3	OUT_TRK	Tracker Output. Bypass OUT_TRK to SGND with a 10 μ F (min) capacitor with low ESR ($\leq 1.5\Omega$).
4	4	ADJ	Tracker Amplifier Input. Connect ADJ to OUT_LDO or to an external source to track. Alternatively, connect ADJ to REF to provide the reference voltage to the tracker.
5	5	SGND	Signal Ground
6	6	PGND	Ground. PGND is also the return path for the overvoltage protector pulldown current for the MAX15008. In this case, connect PGND to SGND at the negative terminal of the bypass capacitor connected to the source of the external MOSFET. For the MAX15010, connect PGND to SGND together to the local ground plane.
7	7	$\overline{\text{RESET}}$	Active-Low Open-Drain Reset Output. $\overline{\text{RESET}}$ is low while OUT_LDO is below the reset threshold. Once OUT_LDO has exceeded the reset threshold, $\overline{\text{RESET}}$ remains low for the duration of the reset timeout period before going high.
9	9	CT	Reset Timeout Adjust Input. Connect a capacitor (C_{RESET}) from CT to ground to adjust the reset timeout period. See the <i>Setting the $\overline{\text{RESET}}$ Timeout Period</i> section.
10	—	FB_PROT	Overvoltage Threshold Adjustment Input. Connect FB_PROT to an external resistive voltage-divider network to adjust the desired overvoltage threshold. Use FB_PROT to monitor a system input or output voltage. See the <i>Setting the Overvoltage Threshold (MAX15008 Only)</i> section.
12	—	GATE	Protector Gate Drive Output. Connect GATE to the gate of an external n-channel MOSFET. GATE is the output of a charge pump with a 45 μ A pullup current to 7.1V (typ) above IN during normal operation. GATE is quickly turned off through a 63mA internal pulldown during an overvoltage condition. GATE then remains low until FB_PROT has decreased 96% below the threshold. GATE pulls low when EN_PROT is low.
13	—	SOURCE	Output-Voltage Sense Input. Connect SOURCE to the source of the external n-channel MOSFET.
14	14	REF	1.235V Voltage Reference Output. Bypass REF to SGND with a 1nF or larger capacitor.

Pin Description (continued)

PIN		NAME	FUNCTION
MAX15008	MAX15010		
15	15	FB_LDO	LDO Voltage Feedback Input. Connect FB_LDO to SGND to select the preset +5V output voltage. Connect FB_LDO to an external resistive voltage-divider for adjustable output operation. See the <i>Setting the Output Voltage</i> section.
16	16	EN_LDO	Active-High LDO Enable Input. Connect EN_LDO to IN or to a logic-high voltage to turn on the regulator. To place the LDO in shutdown, pull EN_LDO low or leave unconnected and leave HOLD unconnected. EN_LDO is internally pulled to SGND through a 1 μ A current sink. See the <i>Control Logic</i> section.
17	17	EN_TRK	Active-High Tracker Enable Input. Connect EN_TRK to IN or to a logic-high voltage to turn on the tracker. Pull EN_TRK low or leave unconnected to place tracker in shutdown. EN_TRK is internally pulled to SGND through a 1 μ A current sink.
18	—	EN_PROT	Protector Enable Input. Drive EN_PROT low to force GATE low and turn off the external n-channel MOSFET. EN_PROT is internally pulled to SGND by a 1 μ A sink. Connect EN_PROT to IN for normal operation.
19, 20	19, 20	IN	Regulator Input. Bypass IN to SGND with a 10 μ F capacitor (ESR \leq 1.5 Ω).
21, 22	21, 22	OUT_LDO	LDO Regulator Output. Bypass OUT_LDO to SGND with a low-ESR capacitor with a minimum value of 22 μ F. Fixed +5V or adjustable output (+1.8V to +11V). See the <i>Setting the Output Voltage</i> section.
25	25	$\overline{\text{HOLD}}$	Active-Low Hold Input. If EN_LDO is high when $\overline{\text{HOLD}}$ is forced low, the regulator latches the state of the EN_LDO input and allows the regulator to remain turned on when EN_LDO is subsequently pulled low. To shut down the regulator, release $\overline{\text{HOLD}}$ after EN_LDO is pulled low. If $\overline{\text{HOLD}}$ functionality is unused, connect $\overline{\text{HOLD}}$ to OUT_LDO or leave unconnected. $\overline{\text{HOLD}}$ is internally pulled up to OUT_LDO through a 0.6 μ A current source. See the <i>Control Logic</i> section.
29	29	FB_TRK	Tracker Amplifier Feedback. Connect FB_TRK directly to OUT_TRK or through an external resistive voltage-divider.
30	30	TRACK	Tracker Input. Bypass TRACK to the SGND with a 3.3 μ F ceramic capacitor.
EP	EP	EP	Exposed Pad. Connect EP to SGND plane. EP also functions as a heatsink to maximize thermal dissipation. Do not use as the main ground connection.

Functional Diagram

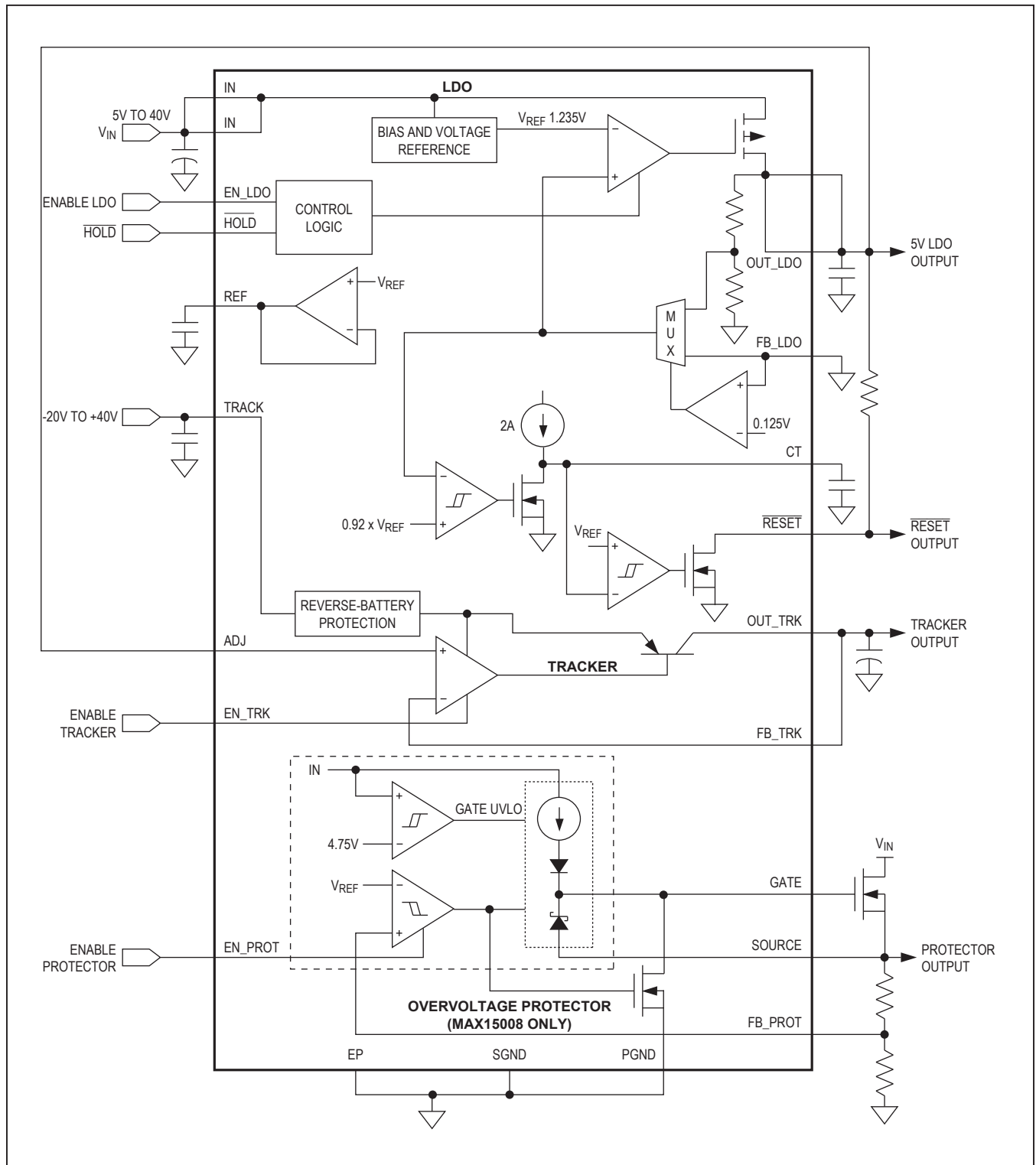

Detailed Description

The MAX15008/MAX15010 integrate a 300mA LDO voltage regulator, a voltage tracker, and an OVP controller. These devices operate over a wide 5V to 40V supply voltage range and are able to withstand voltage transients up to 45V.

The MAX15008/MAX15010 feature a 300mA LDO regulator that consumes less than 70 μ A of current under light-load conditions and feature a fixed 5V or an adjustable output voltage (1.8V to 11V). Connect FB_LDO to ground to select a fixed 5V output voltage, or select the LDO output voltage by connecting an external resistive voltage-divider at FB_LDO. The regulator sources at least 300mA of current and includes a current limit of 330mA (min). Enable the LDO by pulling EN_LDO high.

The tracker can be powered from the LDO input supply voltage or an independent voltage source. It is designed to supply power to a remote sensor and is able to handle the severe conditions in industrial applications. Set the tracker output voltage by connecting a resistive voltage-divider to OUT_TRK and connecting ADJ to the tracking source. The tracker feedback (FB_TRK) and a separate tracker reference voltage input (ADJ) offer the flexibility of setting the tracker output to be lower, equal to, or higher than the main (LDO) output. Pull EN_TRK to SGND to turn the tracker off and keep the device in always-on, low-quiescent-current operation.

The OVP controller (MAX15008 only) relies on an external MOSFET with adequate voltage rating (V_{DSS}) to protect downstream circuitry from overvoltage transients. The OVP controller drives the gate of the external n-channel MOSFET, and is configurable to operate as an overvoltage protection switch or as a closed-loop voltage limiter.

GATE Voltage (MAX15008 Only)

The MAX15008 uses a high-efficiency charge pump to generate the GATE voltage for the external n-channel MOSFET. Once the input voltage (V_{IN}) exceeds the undervoltage-lockout (UVLO) threshold, the internal charge pump fully enhances the external n-channel MOSFET. An overvoltage condition occurs when the voltage at FB_PROT goes above the threshold voltage (V_{TH_PROT}). After V_{TH_PROT} is exceeded, GATE is quickly pulled to PGND with a 63mA pulldown current. The MAX15008 includes an internal clamp to SOURCE that ensures that the voltage at GATE never

exceeds one diode drop below SOURCE during gate discharge. The voltage clamp also prevents the GATE-to-SOURCE voltage from exceeding the absolute maximum rating for the V_{GS} of the external MOSFET in case the source terminal is accidentally shorted to 0V.

Overvoltage Monitoring (MAX15008 Only)

The OVP controller monitors the voltage at FB_PROT and controls an external n-channel MOSFET, isolating, or limiting the load during an overvoltage condition. Operation in OVP switch mode or limiter mode depends on the connection between FB_PROT and the external MOSFET.

Overvoltage Switch Mode

When operating in OVP switch mode, the FB_PROT divider is connected to the drain of the external MOSFET. The feedback path consists of the voltage-divider tapped at FB_PROT, FB_PROT's internal comparator, the internal gate-charge pump/gate pulldown, and the external n-channel MOSFET (Figure 1). When the programmed overvoltage threshold is exceeded, the internal comparator quickly pulls GATE to ground and turns off the external MOSFET, disconnecting the power source from the load. In this configuration, the voltage at the source of the MOSFET is not monitored. When the voltage at FB_PROT decreases below the overvoltage threshold, the MAX15008 raises the voltage at GATE, reconnecting the load to the power source.

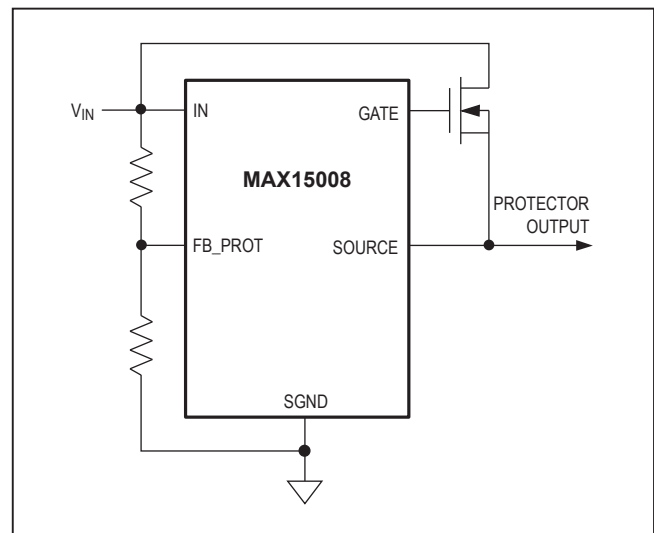

Figure 1. Overvoltage Switch Configuration (MAX15008)

Overvoltage-Limiter Mode

When operating in overvoltage-limiter mode, the feedback path consists of SOURCE, FB_PROT's internal comparator, the internal-gate charge pump/gate pulldown, and the external n-channel MOSFET (Figure 2). This configuration results in the external MOSFET operating as a hysteretic voltage regulator.

During normal operation, GATE is enhanced 8.1V above V_{IN} . The external MOSFET source voltage is monitored through a resistive voltage-divider between SOURCE and FB_PROT. When V_{SOURCE} exceeds the adjustable overvoltage threshold, an internal pulldown switch discharges the gate voltage and quickly turns the MOSFET off. Consequently, the source voltage begins to fall. The V_{SOURCE} fall time is dependent on the MOSFET's gate charge, the internal charge-pump current, the output load, and any load capacitance at SOURCE. When the voltage at FB_PROT is below the overvoltage threshold by an amount equal to the hysteresis, the charge pump restarts and turns the MOSFET back on. In this way, the OVP controller attempts to regulate V_{SOURCE} around the overvoltage threshold. SOURCE remains high during overvoltage transients and the MOSFET continues to conduct during an overvoltage event. The hysteresis of the FB_PROT comparator and the gate turn-on delay force the external MOSFET to operate in a switched on/off sequence during an overvoltage event.

Exercise caution when operating the MAX15008 in voltage-limiting mode for long durations. Care must be taken against prolonged or repeated exposure to overvoltage events while delivering large amounts of load current as the power dissipation in the external MOSFET may be high under these conditions. To prevent damage to the MOSFET, implement proper heatsinking. The capacitor connected between SOURCE and ground can also be damaged if the ripple current rating for the capacitor is exceeded.

As the transient voltage decreases, the voltage at SOURCE falls. For fast-rising transients and very large MOSFETs, connect an additional capacitor from GATE to

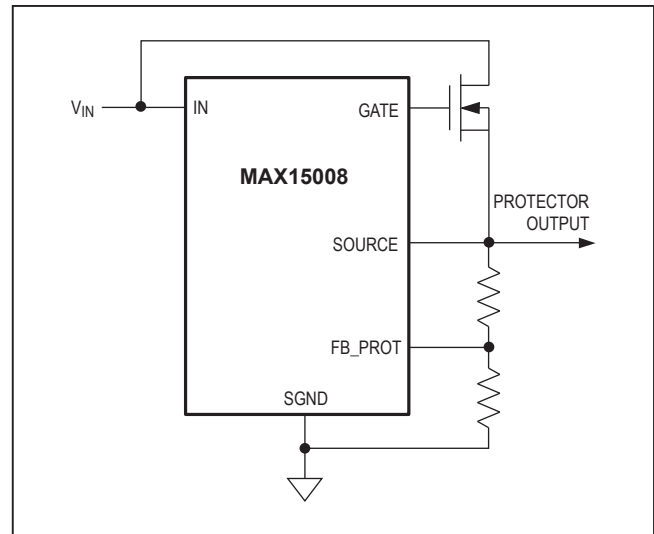

Figure 2. Overvoltage Limiter (MAX15008)

PGND. This capacitor acts as a voltage-divider working against the MOSFET's drain-to-gate capacitance. If using a very low gate-charge MOSFET, additional capacitance from GATE to ground might be required to reduce the switching frequency.

Control Logic

The MAX15008/MAX15010 LDO features two logic inputs ($\overline{EN_LDO}$ and \overline{HOLD}), making these devices suitable for industrial applications. For example, when the ignition key signal drives $\overline{EN_LDO}$ high, the regulator turns on and remains on even if $\overline{EN_LDO}$ goes low, as long as \overline{HOLD} is forced low and stays low after initial regulator power-up. In this state, releasing \overline{HOLD} turns the regulator output ($\overline{OUT_LDO}$) off. This feature makes it possible to implement a self-holding circuit without external components. Forcing $\overline{EN_LDO}$ low and \overline{HOLD} high (or unconnected) places the regulator into shutdown mode, reducing the supply current to less than 16 μ A. Table 1 shows the state of $\overline{OUT_LDO}$ with respect to $\overline{EN_LDO}$ and \overline{HOLD} . Leave \overline{HOLD} unconnected or connect directly to $\overline{OUT_LDO}$ to allow the $\overline{EN_LDO}$ input to act as a standard on/off logic input for the regulator.

Table 1. EN_LDO/HOLD Truth Table/State Table

OPERATION STATE	EN_LDO	HOLD	OUT_LDO	COMMENT
Initial State	Low	Don't care	OFF	EN_LDO is pulled to SGND through an internal pulldown. HOLD is unconnected and is internally pulled up to OUT_LDO. The regulator is disabled.
Turn-On State	High	Don't care	ON	EN_LDO is externally driven high turning regulator on. HOLD is pulled up to OUT_LDO.
Hold Setup State	High	Low	ON	HOLD is externally pulled low while EN_LDO remains high (latches EN_LDO state).
Hold State	Low	Low	ON	EN_LDO is driven low or left unconnected. HOLD remains externally pulled low keeping the regulator on.
Off State	Low	High or unconnected	OFF	HOLD is driven high or left unconnected while EN_LDO is low. The regulator is turned off and EN_LDO/HOLD logic returns to the initial state.

Applications Information

Setting the Output Voltage

The MAX15008/MAX15010 feature dual-mode operation: these devices operate in either a preset voltage mode or an adjustable mode. In preset voltage mode, internal feedback resistors set the linear regulator output voltage (V_{OUT_LDO}) to 5V. To select the preset 5V output voltage, connect FB_LDO to SGND.

To select an adjustable output voltage between 1.8V and 11V, use two external resistors connected as a voltage-divider to FB_LDO (Figure 3). Set the output voltage using the following equation:

$$V_{OUT_LDO} = V_{FB_LDO} \times (R_1 + R_2) / R_2$$

where V_{FB_LDO} = 1.235V and R₂ ≤ 50kΩ.

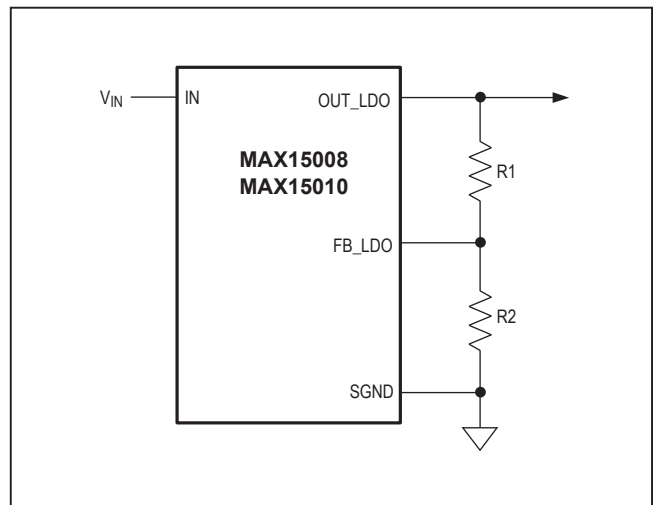

Figure 3. Setting the LDO Output Voltage

Setting the $\overline{\text{RESET}}$ Timeout Period

The $\overline{\text{RESET}}$ timeout period is adjustable to accommodate a variety of applications. Set the $\overline{\text{RESET}}$ timeout period by connecting a capacitor ($C_{\overline{\text{RESET}}}$), between CT and SGND. Use the following formula to select the reset timeout period ($t_{\overline{\text{RESET}}}$):

$$t_{\overline{\text{RESET}}} = C_{\overline{\text{RESET}}} \times V_{CT_TH} / I_{CT}$$

where $t_{\overline{\text{RESET}}}$ is in seconds and $C_{\overline{\text{RESET}}}$ is in μF . V_{CT_TH} is the CT ramp threshold in volts and I_{CT} is the CT ramp current in μA , as described in the *Electrical Characteristics* table.

Leave CT open to select an internally fixed timeout period of $10\mu\text{s}$. To maintain reset timeout accuracy, use a low-leakage ($< 10\text{nA}$) type capacitor.

Tracker Input/Feedback Adjustment

The tracker can be powered from the LDO input supply voltage or an independent voltage source. It is designed to supply power to a remote sensor and its supply input (TRACK) and is able to handle the severe conditions in industrial applications such as battery reversal and load-dump transients up to 45V.

The tracker feedback (FB_TRK) and a separate tracker reference voltage input (ADJ) offer the flexibility of setting

the tracker output to be lower, equal to, or higher than the main (LDO) output. Other external voltages can also be tracked.

Connect ADJ to OUT_LDO and FB_TRK to OUT_TRK to track the LDO output voltage directly (Figure 4a). To track a voltage higher than $V_{\text{OUT_LDO}}$, directly connect ADJ to OUT_LDO and connect FB_TRK to OUT_TRK through a resistive voltage-divider (Figure 4b). To track a voltage lower than the LDO regulator output ($V_{\text{OUT_LDO}}$), directly connect FB_TRK to OUT_TRK and connect ADJ to OUT_LDO through a resistive voltage-divider (Figure 4c). To track an external voltage (V_X) with a generic attenuation/amplification ratio, connect resistive voltage-dividers between ADJ and the voltage input or output to be tracked (V_X), and between OUT_TRK and FB_TRK (Figure 4d). Pay attention to the resistive loading of the voltage V_X due to the divider R5 and R6.

To track the internal REF voltage (1.235V), directly connect ADJ to REF. The voltage at FB_TRK or ADJ should be greater than or equal to 1.1V and less than $V_{\text{TRACK}} - 0.5\text{V}$. Resistors should have a tolerance of 1% or better. Their values should be low enough to ensure that the divider current is at least 100x the maximum input bias current at pins FB_TRK and ADJ ($I_{\text{FB_TRK_ADJ}}$, max = $0.2\mu\text{A}$).

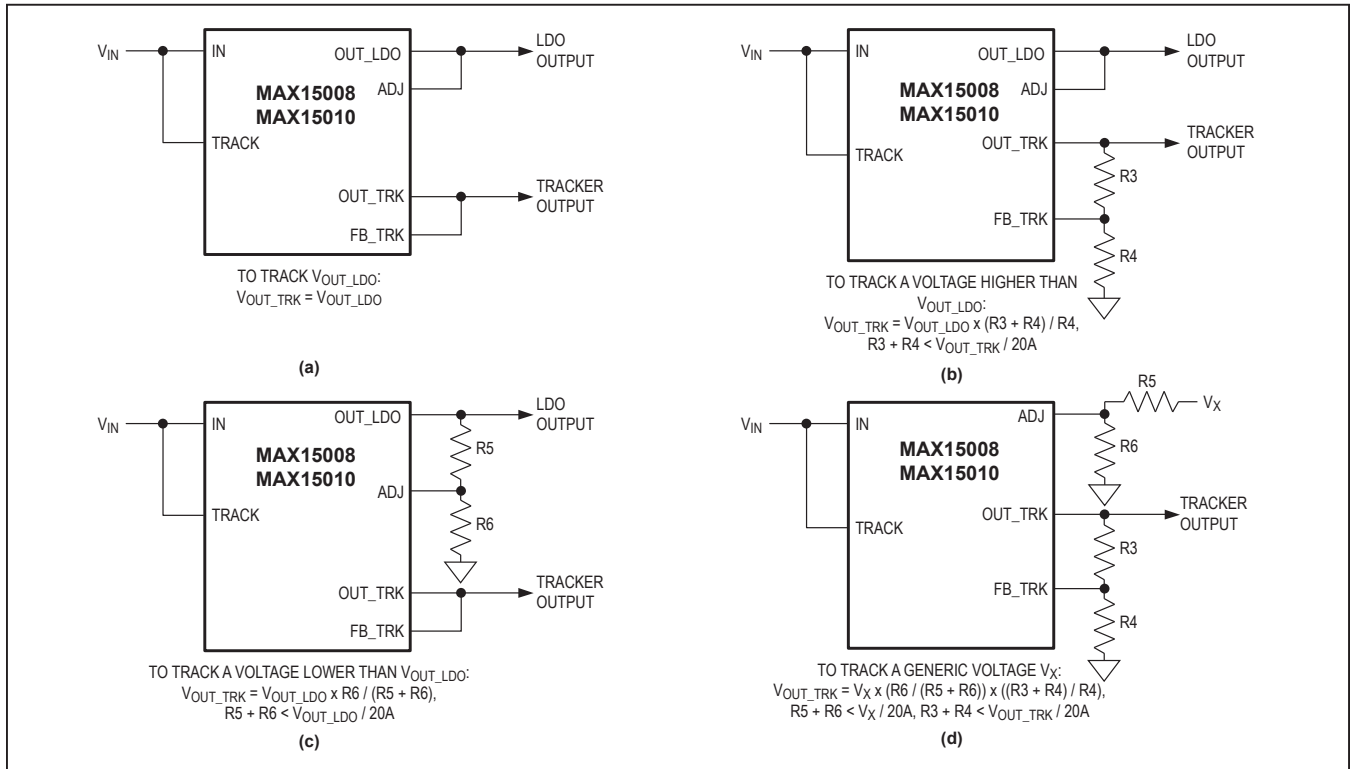

Figure 4. Tracker Input and Feedback Adjustment

Setting the Overvoltage Threshold (MAX15008 Only)

The MAX15008 provides an accurate means to set the overvoltage threshold for the OVP controller using FB_PROT. Use a resistive voltage-divider to set the desired overvoltage threshold (Figure 5). FB_PROT has a rising 1.235V threshold with a 4% falling hysteresis.

Begin by selecting the total end-to-end resistance, $R_{TOTAL} = R_5 + R_6$. Choose R_{TOTAL} to yield a total current equivalent to a minimum of $100 \times I_{FB_PROT}$ (I_{FB_PROT} 's input maximum bias current) at the desired overvoltage threshold. See the *Electrical Characteristics* table.

For example:

With an overvoltage threshold (V_{OV}) set to 20V, $R_{TOTAL} < 20V / (100 \times I_{FB_PROT})$, where I_{FB_PROT} is FB_PROT's maximum 100nA bias current:

$$R_{TOTAL} < 2M\Omega$$

Use the following formula to calculate R_6 :

$$R_6 = V_{TH_PROT} \times R_{TOTAL} / V_{OV}$$

where V_{TH_PROT} is the 1.235V FB_PROT rising threshold and V_{OV} is the desired overvoltage threshold. $R_6 = 124k\Omega$:

$$R_{TOTAL} = R_5 + R_6$$

where $R_5 = 1.88M\Omega$. Use a standard 1.87M Ω resistor.

A lower value for total resistance dissipates more power, but provides better accuracy and robustness against external disturbances.

Input Transients Clamping

When the external MOSFET is turned off during an overvoltage event, stray inductance in the power path may cause additional input-voltage spikes that exceed the V_{DSS} rating of the external MOSFET or the absolute maximum rating for the MAX15008 (IN, TRACK). Minimize stray inductance in the power path using wide traces and minimize the loop area included by the power traces and the return ground path.

For further protection, add a zener diode or transient voltage suppressor (TVS) rated below the absolute maximum rating limits (Figure 6).

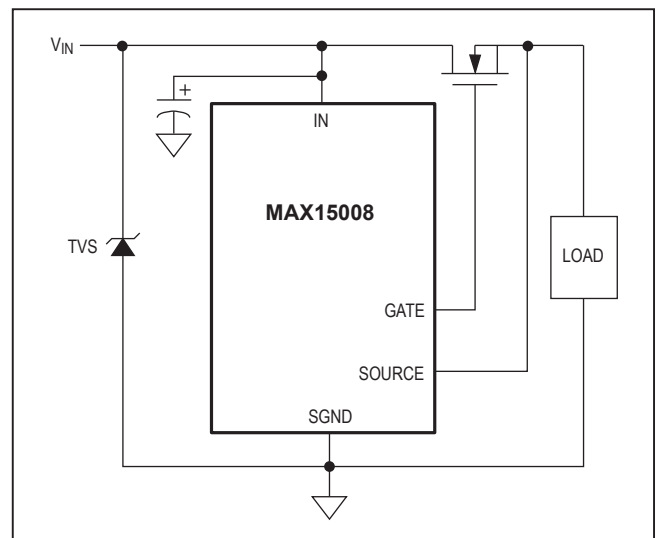

Figure 6. Protecting the MAX15008 Input from High-Voltage Transients

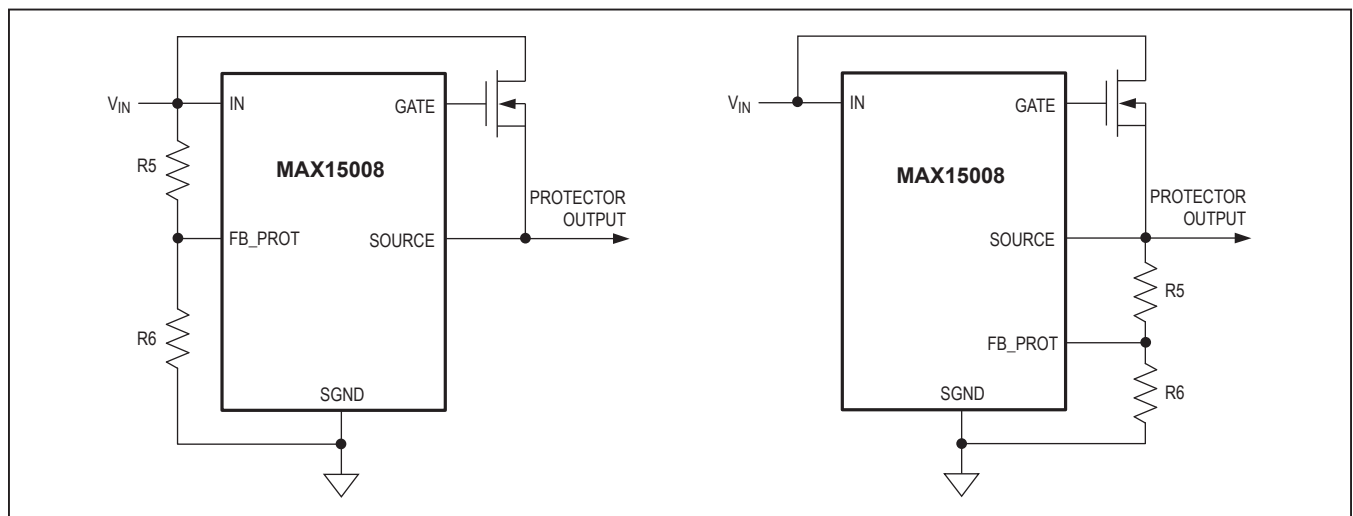

Figure 5. Setting the Overvoltage Threshold (MAX15008)

External MOSFET Selection

Select the external MOSFET with adequate voltage rating (V_{DSS}) to withstand the maximum expected load-dump input voltage. The on-resistance of the MOSFET ($R_{DS(ON)}$) should be low enough to maintain a minimal voltage drop at full load, limiting the power dissipation of the MOSFET.

During regular operation, the power dissipated by the MOSFET is:

$$P_{NORMAL} = I_{LOAD}^2 \times R_{DS(ON)}$$

Normally, this power loss is small and is safely handled by the MOSFET. However, when operating the MAX15008 in overvoltage-limiter mode under prolonged or frequent overvoltage events, select an external MOSFET with an appropriate power rating.

During an overvoltage event, the power dissipation in the external MOSFET is proportional to both load current and to the drain-source voltage, resulting in high power dissipated in the MOSFET (Figure 7). The power dissipated across the MOSFET is:

$$P_{OV_LIMITER} = V_{Q1} \times I_{LOAD}$$

where V_{Q1} is the voltage across the MOSFET's drain and source during overvoltage-limiter operation, and I_{LOAD} is the load current.

Overvoltage-Limiter Mode Switching Frequency

When the MAX15008 is configured in overvoltage-limiter mode, the external n-channel MOSFET is

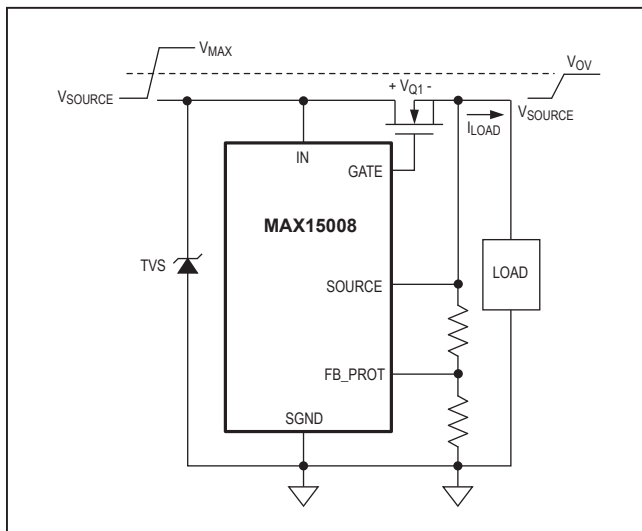

Figure 7. Power Dissipated Across MOSFETs During an Overvoltage Fault (Overvoltage-Limiter Mode)

subsequently switched on and off during an overvoltage event. The output voltage at SOURCE resembles a periodic sawtooth waveform. Calculate the period of the waveform (t_{OVP}) by summing three time intervals (Figure 8):

$$t_{OVP} = t_1 + t_2 + t_3$$

where t_1 is the V_{SOURCE} output discharge time, t_2 is the GATE delay time, and t_3 is the V_{SOURCE} output charge time.

During an overvoltage event, the power dissipated inside the MAX15008 is due to the gate pulldown current (I_{GATEPD}). This amount of power dissipation is worse when $I_{SOURCE} = 0$ (C_{SOURCE} is discharged only by the internal current sink).

The worst-case internal power dissipation contribution in overvoltage-limiter mode (P_{OVP}) in watts can be approximated using the following equation:

$$P_{OVP} = V_{OV} \times 0.98 \times I_{GATEPD} \times \frac{t_1}{t_{OVP}}$$

where V_{OV} is the overvoltage-threshold voltage in volts and I_{GATEPD} is the 63mA (typ) GATE pulldown current.

Output Discharge Time (t_1)

When the voltage at SOURCE exceeds the adjusted overvoltage threshold, GATE's internal pulldown is enabled until V_{SOURCE} drops by 4%. The internal current sink (I_{GATEPD}) and the external load current (I_{LOAD}), discharge the external capacitance from SOURCE to ground.

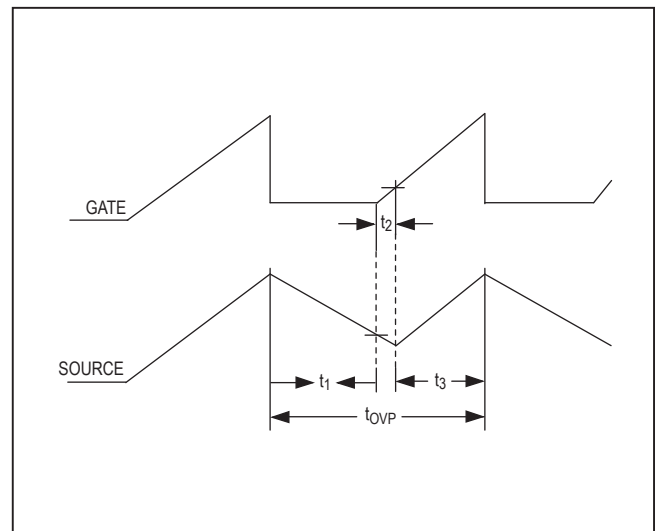

Figure 8. MAX15008 Timing Diagram

Calculate the discharge time (t_1) using the following equation:

$$t_1 = C_{\text{SOURCE}} \times \frac{0.04 \times V_{\text{OV}}}{I_{\text{LOAD}} + I_{\text{GATEPD}}}$$

where t_1 is in ms, V_{OV} is the adjusted overvoltage threshold in volts, I_{LOAD} is the external load current in mA, and I_{GATEPD} is the 63mA (typ) internal pulldown current of GATE. C_{SOURCE} is the value of the capacitor connected between the source of the MOSFET and PGND in μF .

GATE Delay Time (t_2)

When SOURCE falls 4% below the overvoltage threshold voltage, the internal current sink is disabled and the internal charge pump begins recharging the external GATE voltage. Due to the external load, the SOURCE voltage continues to drop until the gate of the MOSFET is recharged. The time needed to recharge GATE and reenable the external MOSFET is approximately:

$$t_2 = C_{\text{ISS}} \times \frac{V_{\text{GS(TH)}} + V_{\text{F}}}{I_{\text{GATE}}}$$

where t_2 is in μs , C_{ISS} is the input capacitance of the MOSFET in pF, and $V_{\text{GS(TH)}}$ is the gate-to-source threshold voltage of the MOSFET in volts. V_{F} is the 0.7V (typ) internal clamp-diode forward voltage of the MOSFET in volts, and I_{GATE} is the charge-pump current, 45 μA (typ). Any external capacitance between GATE and PGND adds up to C_{ISS} .

During t_2 , the SOURCE capacitance (C_{SOURCE}) loses charge through the output load. The voltage across C_{SOURCE} decreases by ΔV_2 until the MOSFET reaches its $V_{\text{GS(TH)}}$ threshold. Approximate ΔV_2 using the following formula:

$$\Delta V_2 = \frac{I_{\text{LOAD}} \times t_2}{C_{\text{SOURCE}}}$$

SOURCE Output Charge Time (t_3)

Once the GATE voltage exceeds the gate-to-source threshold ($V_{\text{GS(TH)}}$) of the external MOSFET, the MOSFET turns on and the charge through the internal charge pump with respect to the drain potential (Q_{G}) determines the slope of the output-voltage rise. The time required for the SOURCE voltage to rise again to the overvoltage threshold is:

$$t_3 = \frac{C_{\text{RSS}} \times \Delta V_{\text{SOURCE}}}{I_{\text{GATE}}}$$

where $\Delta V_{\text{SOURCE}} = (V_{\text{OV}} \times 0.04) + \Delta V_2$ in volts, and C_{RSS} is the MOSFET's reverse-transfer capacitance in pF. Any external capacitance between GATE and PGND adds up to C_{RSS} .

Power Dissipation/Junction Temperature

During normal operation, the MAX15008/MAX15010 have two main sources of internal power dissipation: the LDO and the voltage tracker.

Calculate the power dissipation due to the LDO as:

$$P_{\text{LDO}} = (V_{\text{IN}} - V_{\text{OUT_LDO}}) \times I_{\text{OUT_LDO}}$$

where V_{IN} is the LDO input supply voltage in volts, $V_{\text{OUT_LDO}}$ is the output voltage of the LDO in volts, and $I_{\text{OUT_LDO}}$ is the LDO total load current in mA.

Calculate power dissipation due to the tracker as:

$$P_{\text{TRK}} = (V_{\text{TRACK}} - V_{\text{OUT_TRK}}) \times I_{\text{OUT_TRK}}$$

where V_{TRACK} is the tracker input-supply voltage in volts, $V_{\text{OUT_TRK}}$ is the output voltage of the tracker in volts, and $I_{\text{OUT_TRK}}$ is the tracker load current in mA.

The total power dissipation P_{DISS} in mW as:

$$P_{\text{DISS}} = P_{\text{LDO}} + P_{\text{TRK}}$$

For prolonged exposure to overvoltage events, use the V_{IN} and V_{TRACK} voltages expected during overvoltage conditions. Under these circumstances, the corresponding internal power-dissipation contribution (P_{OVP}) calculated in the *Overvoltage-Limiter Mode Switching Frequency* section should also be included in the total power dissipation (P_{DISS}).

For a given ambient temperature (T_{A}), calculate the junction temperature (T_{J}) as follows:

$$T_{\text{J}} = T_{\text{A}} + P_{\text{DISS}} \times \theta_{\text{JA}}$$

where T_{J} and T_{A} are in $^{\circ}\text{C}$ and θ_{JA} is the junction-to-ambient thermal resistance in $^{\circ}\text{C}/\text{W}$, as listed in the *Absolute Maximum Ratings* section.

The junction temperature should never exceed $+150^{\circ}\text{C}$ during normal operation.

Thermal Protection

When the junction temperature exceeds $T_{\text{J}} = +160^{\circ}\text{C}$, the MAX15008/MAX15010 shut down to allow the device to cool. When the junction temperature drops to $+140^{\circ}\text{C}$, the thermal sensor turns all enabled blocks on again, resulting in a cycled output during continuous thermal-overload conditions. Thermal protection protects the MAX15008/MAX15010 from excessive power dissipation. For continuous operation, do not exceed the absolute maximum junction temperature rating of $+150^{\circ}\text{C}$.

Typical Operating Circuits

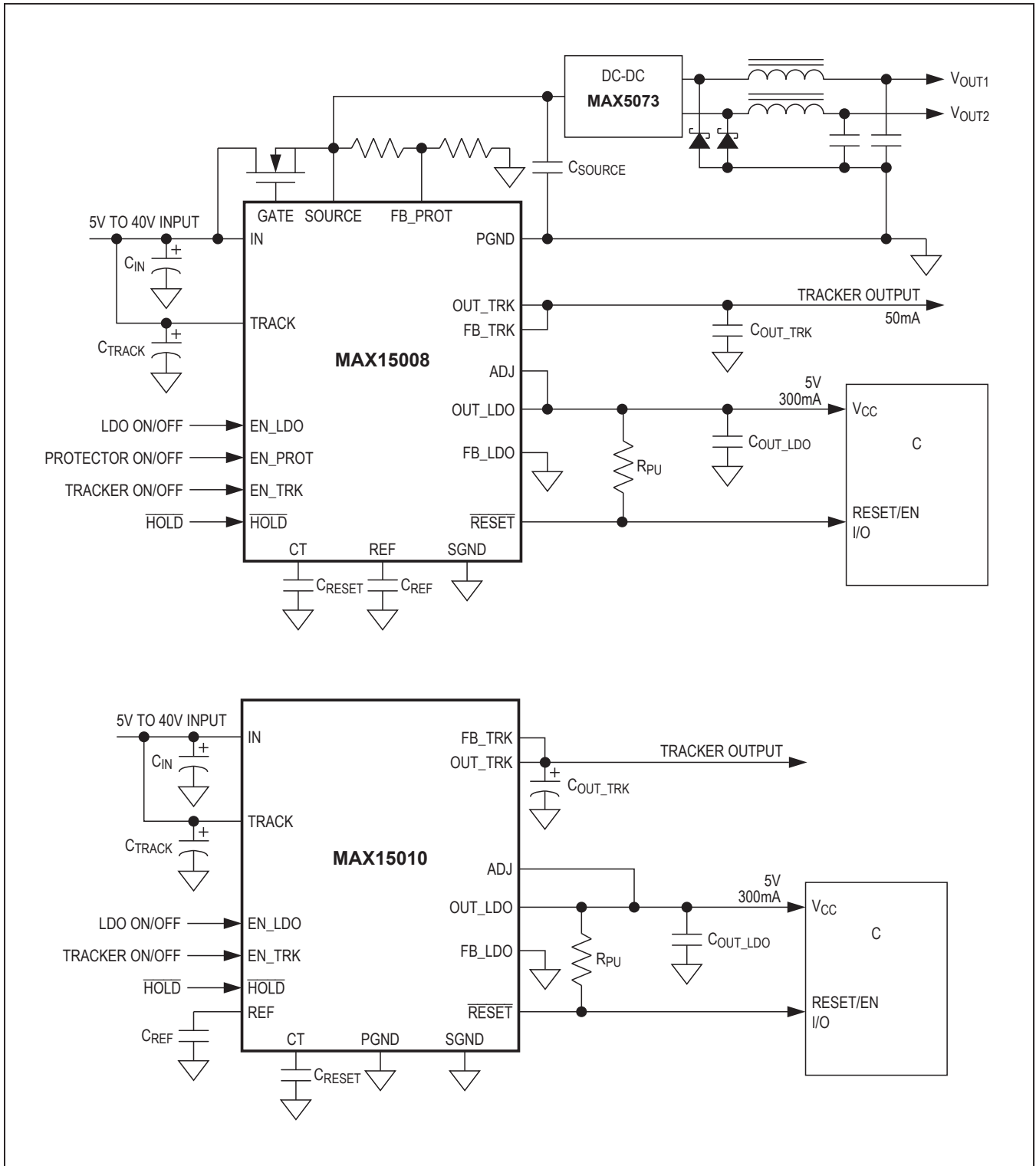

Pin Configurations (continued)

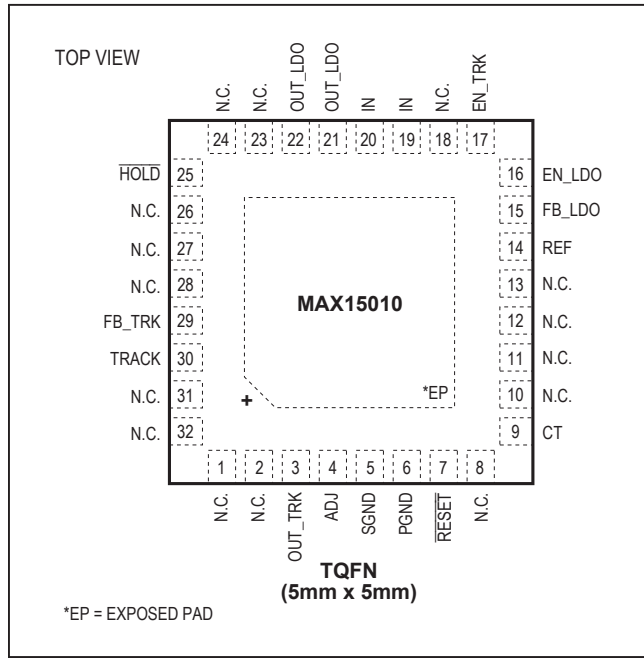

Chip Information

PROCESS: BiCMOS

Package Information

For the latest package outline information and land patterns (footprints), go to www.maximintegrated.com/packages. Note that a "+", "#", or "-" in the package code indicates RoHS status only. Package drawings may show a different suffix character, but the drawing pertains to the package regardless of RoHS status.

PACKAGE TYPE	PACKAGE e CODE	OUTLINE NO.	LAND PATTERN NO.
32 TQFN-EP	T3255+4	21-0140	90-0012

Revision History

REVISION NUMBER	REVISION DATE	DESCRIPTION	PAGES CHANGED
0	9/07	Initial release	—
1	1/08	Removed future product asterisks, updated <i>Electrical Characteristics</i> table and <i>Typical Operating Characteristics</i> section.	1, 2, 6, 8
2	2/15	No /V OPNs in <i>Ordering Information</i> ; removed automotive references from <i>General Description</i> , <i>Features</i> , <i>Applications</i> , <i>Detailed Description</i> , <i>Control Logic</i> , <i>Applications Information</i> , and <i>Tracker Input/Feedback Adjustment</i> sections; added <i>Package Information</i> table	1, 13–16, 22–24

For pricing, delivery, and ordering information, please contact Maxim Direct at 1-888-629-4642, or visit Maxim Integrated's website at www.maximintegrated.com.

Maxim Integrated cannot assume responsibility for use of any circuitry other than circuitry entirely embodied in a Maxim Integrated product. No circuit patent licenses are implied. Maxim Integrated reserves the right to change the circuitry and specifications without notice at any time. The parametric values (min and max limits) shown in the *Electrical Characteristics* table are guaranteed. Other parametric values quoted in this data sheet are provided for guidance.