

LED FLYBACK CONTROL IC

Features

- Flyback LED Driver
- Critical-conduction / Transition mode operation
- Primary constant power control
- Burst mode operation at light load
- Over-current protection
- Micropower startup (150 μ A)
- Low quiescent current (2.5 mA)
- Latch immunity and ESD protection
- Open load over voltage protection
- Noise immunity

Product Summary

Topology	Flyback
I_{o+} & I_{o-} (typical)	200 mA / 400 mA
t_r & t_f (typical)	60 ns / 30 ns

Typical Applications

- LED Drivers

Package



Ordering Information

Base Part Number	Package Type	Standard Pack		Complete Part Number
		Form	Quantity	
IRS2983SPBF	SO8N	Tube/Bulk	95	IRS2983SPBF
		Tape and Reel	2500	IRS2983STRPBF

Table of Contents	Page
Description	3
Qualification Information	4
Absolute Maximum Ratings	5
Recommended Operating Conditions	5
Electrical Characteristics	6
Functional Block Diagram	8
State Diagram	9
Input/Output Pin Equivalent Circuit Diagram	10
Lead Definitions	11
Lead Assignments	11
Application Information and Additional Details	12
Package Details	15
Tape and Reel Details	16
Part Marking Information	17

Description

The IRS2983 is a fully integrated, fully protected SMPS control IC designed to drive Flyback converter LED drivers. The IRS2983 features include primary side power regulation, which allows a basic converter to be implemented without the need for an opto isolator in a Flyback LED driver with a fixed load enabling a low cost, high reliability isolated LED driver design to be realized. The IRS2983 may also be used in converters that do include secondary feedback through an opto isolator. Other features of the IRS2983 include a high voltage startup enabling VCC supply to be derived initially from the high voltage DC bus until the auxiliary inductor winding is able to take over. The IRS2983 operates in critical conduction (CrCM) or discontinuous (DCM) modes and is fully protected against open and short circuit as well as inductor saturation. The IRS2983 may be used in single stage Flyback LED drivers with an unsmoothed DC bus to obtain high power factor and low THD.

Typical Connection Diagram

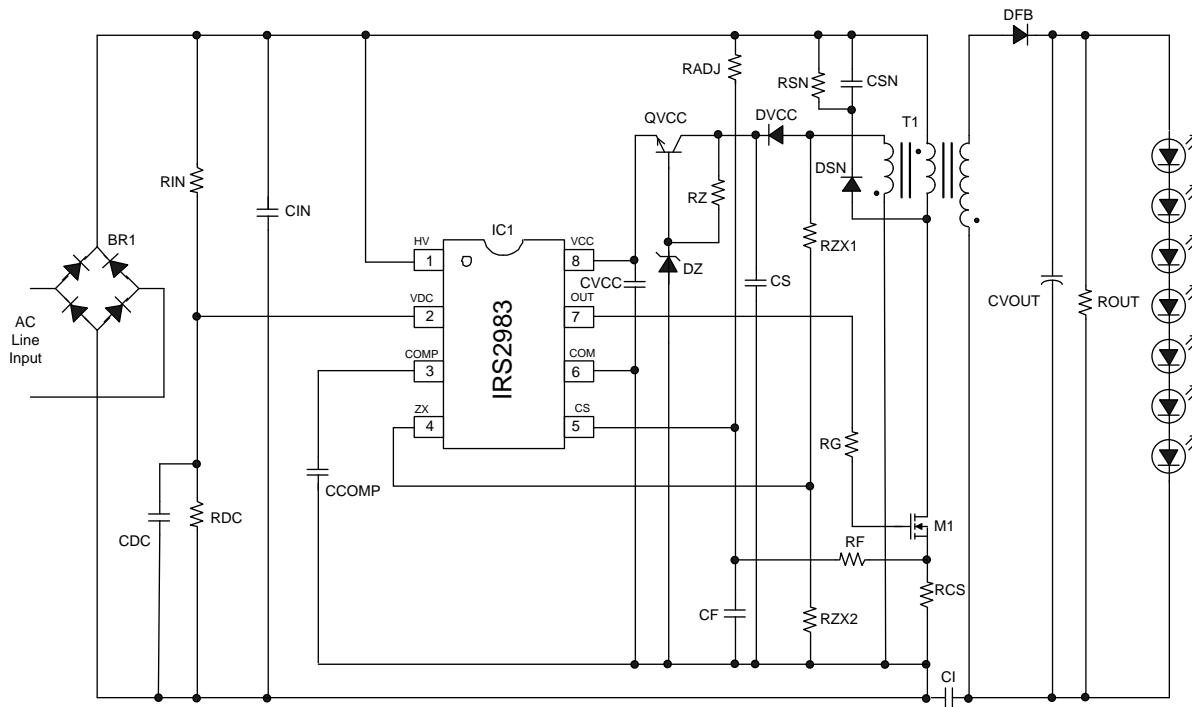

Qualification Information[†]

Qualification Level		Industrial ^{††}	
		Comments: This family of ICs has passed JEDEC's Industrial qualification. IR's Consumer qualification level is granted by extension of the higher Industrial level.	
Moisture Sensitivity Level		SOIC8	MSL2 ^{†††} 260°C (per IPC/JEDEC J-STD-020)
ESD	Machine Model	Class B (per JEDEC standard JESD22-A115)	
	Human Body Model	Class 1C (per EIA/JEDEC standard EIA/JESD22-A114)	
IC Latch-Up Test		Class I, Level A (per JESD78)	
RoHS Compliant		Yes	

† Qualification standards can be found at International Rectifier's web site <http://www.irf.com/>

†† Higher qualification ratings may be available should the user have such requirements. Please contact your International Rectifier sales representative for further information.

††† Higher MSL ratings may be available for the specific package types listed here. Please contact your International Rectifier sales representative for further information.

Absolute Maximum Ratings

Absolute maximum ratings indicate sustained limits beyond which damage to the device may occur. All voltage parameters are absolute voltages referenced to COM, all currents are defined positive into any lead. The thermal resistance and power dissipation ratings are measured under board mounted and still air conditions.

Symbol	Definition	Min.	Max.	Units	
V_{CC}	IC Low Voltage Supply [†]	---	20.8	V	
V_{OUT}	Gate Driver Output Voltage	-0.3	$V_{CC} + 0.3$		
$I_{O_{MAX}}$	Maximum allowable output current (OUT) due to external power transistor Miller effect	-800	600	mA	
I_{CC}	VCC current	0	25	mA	
V_{HV}	HV Pin Voltage	-0.3	600	V	
V_{COMP}	COMP Pin Voltage	-0.3	$V_{CC} + 0.3$		
V_{DC}	VDC Pin Voltage				
V_{ZX}	ZX Pin Voltage				
I_{COMP}	COMP Pin Current	-5	5	mA	
I_{ZX}	ZX Pin Current				
I_{CS}	CS Pin Current				
P_D	Package Power Dissipation @ $T_A \leq +25^\circ\text{C}$ $P_D = (T_{JMAX} - T_A) / R_{\theta JA}$	(8-Pin SOIC)	---	1	W
$R_{\theta JA}$	Thermal Resistance, Junction to Ambient	(8-Pin SOIC)	---	200	$^\circ\text{C}/\text{W}$
T_J	Junction Temperature	-55	150	$^\circ\text{C}$	
T_S	Storage Temperature	-55	150		
T_L	Lead Temperature (soldering, 10 seconds)	---	300		

[†] This IC contains a zener clamp structure between the chip V_{CC} and COM which has a nominal breakdown voltage of 20V. This supply pin should not be driven by a DC, low impedance power source greater than the V_{CLAMP} specified in the Electrical Characteristics section.

Recommended Operating Conditions

For proper operation the device should be used within recommended conditions.

Symbol	Definition	Min.	Max.	Units
V_{CC}	Supply Voltage	V_{CCUV+}	18	V
I_{CC}	V_{CC} Supply Current	0	10	mA
I_{CS}	CS Pin Current	-1	1	
I_{ZX}	ZX Pin Current			
V_{DC}	VDC Pin Voltage	0	6.0	V
V_{CS}	CS Pin Voltage	0.1	1.3	
T_J	Junction Temperature	-25	125	$^\circ\text{C}$

Electrical Characteristics
 $V_{CC} = 14V \pm 0.25V$, $C_{OUT} = 1000pF$,

 $V_{COMP} = V_{OC} = V_{BUS} = V_{ZX} = 0V$, $T_A = 25^\circ C$ unless otherwise specified

Symbol	Definition	Min	Typ	Max	Units	Test Conditions
Supply Characteristics						
V_{CCUV+}	V_{CC} Supply Undervoltage Positive Going Threshold	11.5	12.5	13.5	V	
V_{CCUV-}	V_{CC} Supply Undervoltage Negative Going Threshold	9.5	10.5	11.5		
V_{UVHYS}	V_{CC} Supply Undervoltage Lockout Hysteresis	1.5	2.0	3.0		
I_{QCCUV}	UVLO Mode V_{CC} Quiescent Current	---	150	---	μA	$V_{CC} = 6V$
I_{CC}	V_{CC} Supply Current	---	2.5	5.0	mA	
V_{CLAMP}	V_{CC} Zener Clamp Voltage	19.8	20.8	21.8	V	$I_{CC} = 10mA$
High Voltage Startup Characteristics						
V_{HVSMIN}	Minimum startup voltage	30.0	---	---		
I_{HV_CHARGE}	V_{CC} charge current	1	2	---	mA	$V_{CC} < V_{CCUV-}$ HV=100V~400V
I_{HVS_OFF}	High voltage start-up circuit OFF state leakage current	---	---	50	μA	HV=400V
Error Amplifier Characteristics						
I_{COMP_SOURCE}	COMP Pin Error Amplifier Output Current Sourcing	---	30	---	μA	
I_{COMP_SINK}	COMP Pin Error Amplifier Output Current Sinking	---	30	---		
V_{COMPOH}	Error Amplifier Output Voltage Swing (high state)	---	13.5	---	V	
V_{COMPOL}	Error Amplifier Output Voltage Swing (low state)	---	2.5	---		GBD
$V_{COMPFLT}$	Error Amplifier Output Voltage in Fault Mode	---	0	---		
I_{VBUS}	Input bias current	---	-1	---	μA	$V_{BUS} = 0$ to 3V
Control Characteristics						
V_{ZX+}	ZX Pin Threshold Voltage (Arm)	1.40	1.54	1.68	V	
V_{ZX-}	ZX Pin Threshold Voltage (Trigger)	0.52	0.60	0.68		
V_{PREF}	Power Regulation Reference	---	1.00	---		
K_{MULT}	Multiplier Gain	1.90	2.00	2.10		$V_{CS} = 0.5V$
t_{BLANK}	OC pin current-sensing blank time	160	200	264	ns	$V_{BUS} = 2.5V$ COMP=4.0V CS=1.5V
t_{WD}	Gate Drive Restart Pulse Interval	60	100	135	μs	ZX = 0 COMP = 4.0V
t_{ONMIN}	PWM Minimum ON time	136	167	198	ns	
t_{ONMAX}	PWM Maximum ON Time	22	32	42	μs	ZX = 0 COMP = 13V

Electrical Characteristics (cont'd)
 $V_{CC} = 14V \pm 0.25V$, $C_{OUT} = 1000pF$,

 $V_{COMP} = V_{OC} = V_{BUS} = V_{ZX} = 0V$, $T_A = 25^\circ C$ unless otherwise specified.

Symbol	Definition	Min	Typ	Max	Units	Test Conditions
t_{OFFMIN}	PWM Minimum OFF Time	2.7	3.0	3.3	μs	
$V_{COMPOFF_HYS}$	Cut off voltage hysteresis	---	40	---	mV	
V_{DCMAX}	Maximum voltage for multiplier input [†]	---	---	7.0	V	GBD
$V_{CSPKMAX}$	Maximum peak voltage for multiplier input [†]	---	---	1.0	V	Signal is averaged before entering multiplier input. GBD
Protection Circuitry Characteristics						
V_{CSTH}	CS Pin Over-current Sense Threshold	1.19	1.25	1.31	V	$V_{BUS} = 2.6V$
$V_{COMPOFF}$	Cut off voltage below which gate drive output is disabled	1.12	1.40	1.68		
V_{OVTH}	ZX Pin Over-voltage Comparator Threshold	4.90	5.15	5.40		
V_{OVHYS}	ZX Pin Over-voltage Comparator Hysteresis	---	200	---	mV	
Gate Driver Output Characteristics (OUT pin)						
V_{OL}	Low-Level Output Voltage	---	0	100	mV	$I_O = 0$
V_{OH}	High-Level Output Voltage	---	0	100		$V_{CC} - V_O$ $I_O = 0$
t_r	Turn-On Rise Time	---	60	110	ns	
t_f	Turn-Off Fall Time	---	30	70		
I_{O+}	Source Current	---	200	---	mA	
I_{O-}	Sink Current	---	400	---		

[†] Multiplier operates accurately from zero to the maximum input specified.

GBD Guaranteed by design

Functional Block Diagram

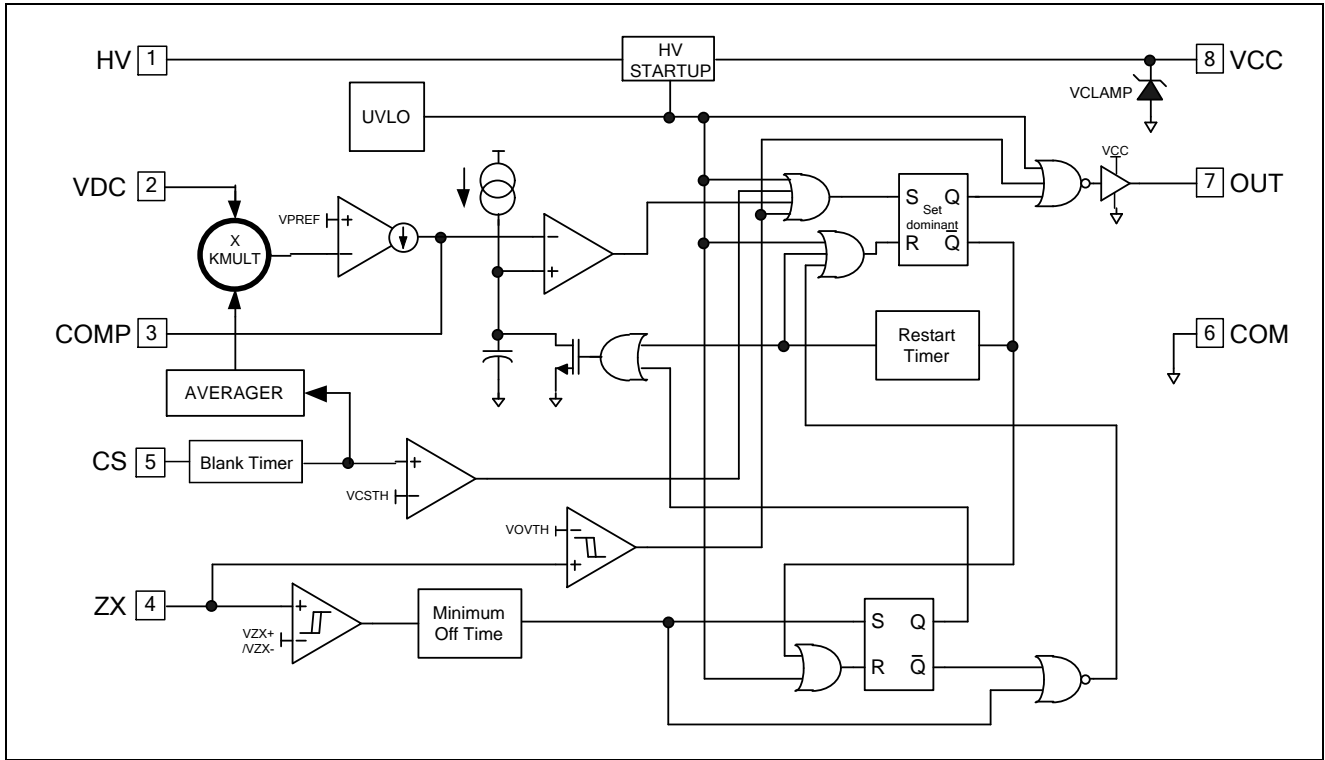

State Diagram

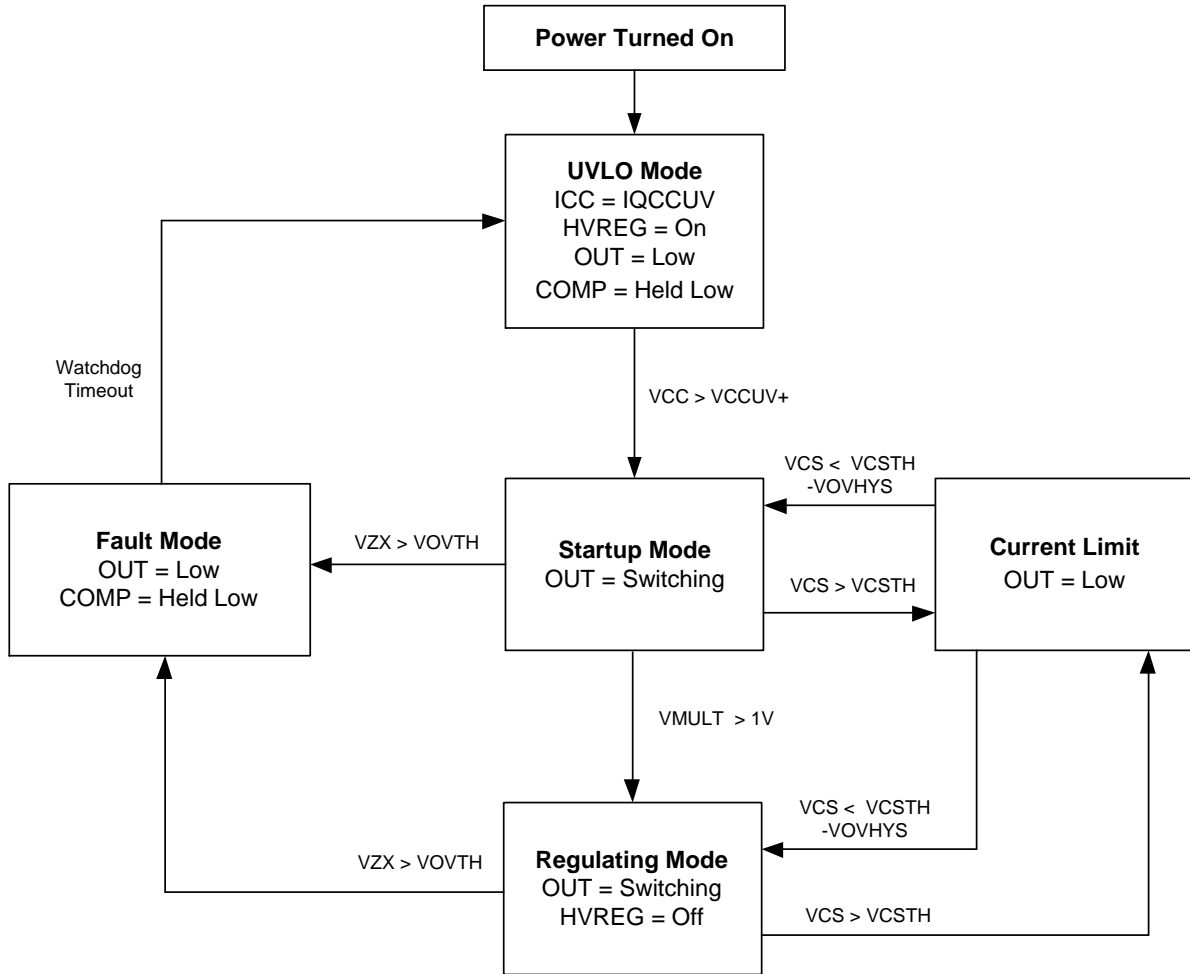

Input/Output Pin Equivalent Circuit Diagrams

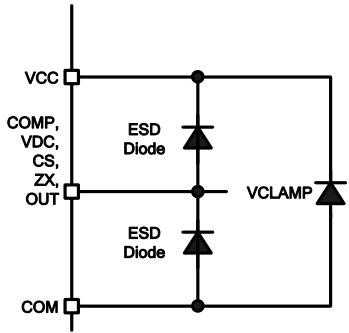

Lead Definitions

Symbol	Description
HV	High Voltage Startup Input
VDC	Full Wave Voltage Input
COMP	Compensation and averaging capacitor input
ZX	PFC Zero-Crossing & Over-Voltage Detection
CS	PFC Current Sensing Input
COM	IC Power & Signal Ground
OUT	Gate Driver Output
VCC	Logic & Low-Side Gate Driver Supply

Lead Assignments

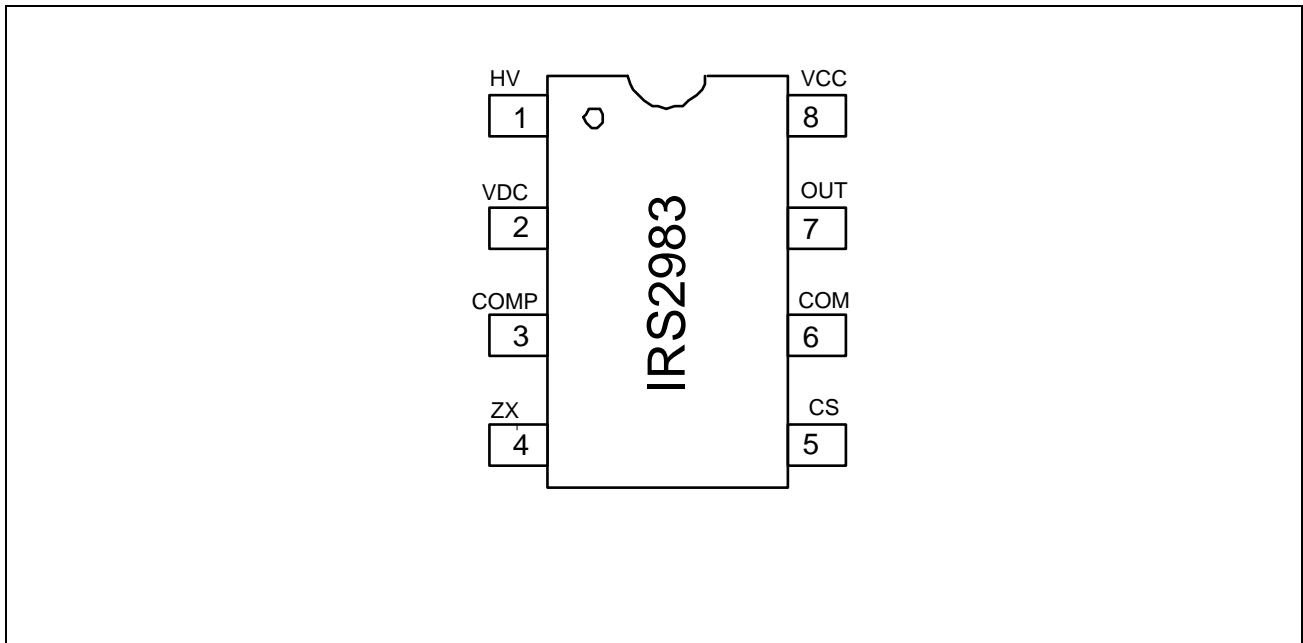

Application Information and Additional Details

The IRS2983 is a switched mode controller IC designed for use in Flyback or Buck-Boost LED drivers. An internal high voltage regulator supplies the IC low voltage VCC supply during startup allowing operation directly from a DC input voltage up to 600V.

Internal high voltage regulator

In order to begin operating the IRS2983 requires the low voltage VCC supply to be raised above the under voltage lockout positive threshold (VCCUV+) and to continue operating VCC must be maintained above the under voltage lockout negative threshold (VCCUV-).

The HV regulator enables the IRS2983 based LED driver to start up very rapidly and deliver light within 0.5s of switch on over the range of line voltage input. When the switching converter is running VCC is normally supplied through an auxiliary winding. When operating with primary regulation (see below) as steady state operation is reached the HV regulator is deactivated.

The auxiliary winding from the Flyback or Buck-Boost inductor/transformer provides output voltage and zero-crossing (ZX) information as well as supplying VCC.

In the event of a short circuit at the output the VCC supply from the auxiliary winding collapses below VCCUV- causing the IRS2983 to shut off. The startup sequence begins again in a continuous “hiccup” mode until the short circuit is removed thereby preventing damage to the circuit.

Primary power regulation

The IRS2983 can operate using primary regulation or using a secondary feedback loop. It is capable of regulating the LED output current indirectly by calculating and controlling the input power of the converter. Since the LED load voltage is essentially constant, the power consumed is approximately proportional to the DC output current. In practice there are variations in LED forward voltage drop due to tolerance and temperature, however perfect accuracy is not usually necessary in such applications. For a fixed LED load the current will be approximately proportional to the input power. The IRS2983 senses input voltage and inductor current and uses these quantities to estimate the input power.

This “power” is then regulated against an accurate internal reference (VPREF) to provide regulation of the LED current typically within +/-5% over line voltage variation from 120VAC to 230VAC.

Input voltage is sensed through an appropriately scaled resistor divider (RIN and RDC) to provide a voltage at VDC within the range from 0V to VDCMAX. Input current is sensed through a shunt resistor (RCS) connected from the source of the Flyback MOSFET switch to the DC bus return. This current waveform is a high frequency ramp rising from zero at the beginning of each switching cycle to reach a peak level at the point the MOSFET is switched off and remaining at zero during the off time.

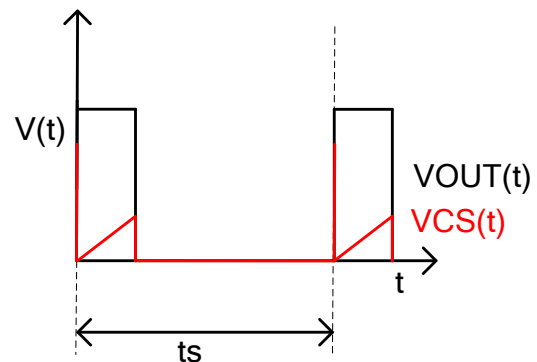

Figure 1: Current sense waveform

In order to obtain a DC current feedback signal the IRS2983 contains an averaging circuit that takes the CS pin input and converts it to a DC level proportional to the converters input current. This signal is then multiplied with the voltage (VDC) input to produce an internal voltage proportional to the converter input power. Loop compensation is performed by means of a transconductance error amplifier using an external capacitor (CCOMP) connected to 0V to realize an integrator that provides a stable error voltage used to control the converter on time. CCOMP is typically 1 μ F.

The output current normally increases by a small amount as the input voltage is increased. RADJ is a resistor in the order of Meg-Ohms that can be added to provide a small feed forward correction to the current sense input allowing the output current to be fine-tuned to give tighter regulation over a wide input voltage range.

At light loads if VCOMP drops below VCOMPOL the IRS2983 operates in burst mode.

Primary current limiting

At very low input voltages the power regulation loop would require a very high peak current that may exceed the maximum rating of the inductor. In order to prevent this from occurring, the IRS2983 also includes cycle by cycle primary current limiting with a threshold VCSTH at the CS pin input. Under low line or fault conditions where the MOSFET current is abnormally high the gate drive is switched off after the blanking time tBLANK. Leading edge blanking is necessary to avoid false tripping due to the fast high current switch on transient that occurs at switch on of the MOSFET resulting from the circuit parasitics. This is also blanked from the averaging input that feeds the power regulation multiplier in order to prevent inaccuracies.

The IRS2983 normally operates in critical conduction mode (CrCM), also known as transition or boundary mode. The transformer auxiliary winding provides a signal to the IRS2983 that indicates when all of the energy stored in the inductor has been transferred to the output. This triggers the start of the next switching cycle. The auxiliary winding voltage is divided down through RZX1 and RZX2 to provide the ZX pin input signal.

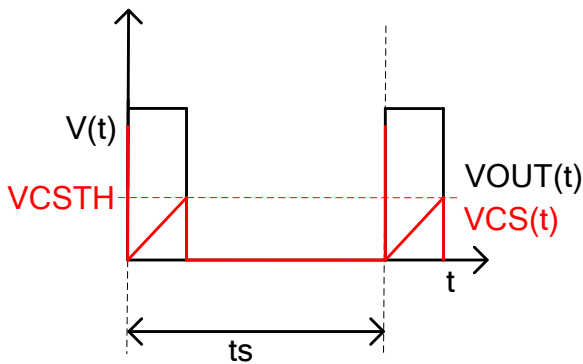

Figure 2: Cycle by cycle current limiting

The pulse that appears at ZX has an amplitude proportional to the secondary output voltage and therefore the DC output voltage:

$$V_{ZX} = \frac{N_A \cdot R_{ZX2} \cdot V_{OUT}}{N_S \cdot (R_{ZX1} + R_{ZX2})} \quad [1]$$

where,

- N_A = Number of turns on the auxiliary winding
- N_S = Number of turns on the secondary winding
- V_{OUT} = DC Output Voltage (LED voltage)

When the converter MOSFET switches off the voltage VZX transitions high. The values of RZX1 and RZX2 must be selected so that this voltage always exceeds the VZX+ threshold.

If the IRS2983 is used in a converter that is required to drive loads over a range of voltage an additional feedback circuit is needed to control the output current. In this case the VZX voltage needs to exceed VZX+ at the *minimum* load voltage. If VZX does not exceed VZX+ the IRS2983 cannot operate in CrCM and remains pulsing and waiting for tWD timeout for the next cycle. When VZX exceeds VZX+ the IRS2983 waits until the VZX then drops below VZX- again to initiate the next switching cycle. A capacitor may be added in parallel with RZX2 to add some delay if needed to minimize switching loss by switching on in the minimum point or “valley” of the drain voltage.

The IRS2983 includes a minimum off time function so that if the ZX pin input transitions high and low before tOFFMIN the gate drive output will not go high again until after this period. This prevents false tripping by ringing at the ZX input and also limits the converter maximum switching frequency by entering discontinuous mode (DCM) under conditions where the off time would otherwise be very short. This function extends the operating range of the converter allowing operation down to very low duty cycles. This thereby enables dimming designs to be implemented as well as limiting operating frequency to prevent overheating of the circuit inductor, MOSFET and snubber components.

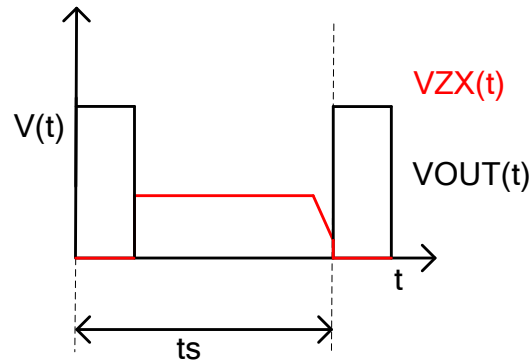

Figure 3: Zero crossing detection

Over voltage protection

The ZX is a multi-function input also used for output over voltage limiting. In a Flyback or Buck-Boost converter if the load becomes disconnected the output voltage can become very high causing damage to components as well as presenting an electrical hazard. In order to protect against this the IRS2983 senses the output voltage indirectly through the ZX input, which is proportional to the actual output voltage. If the ZX input voltage exceeds VOVTH when the MOSFET switches off the gate drive remains switched off for a tWD period before starting the next cycle regardless of when the ZX voltage transitions low. The IRS2983 also discharges the COMP capacitor to zero so that the next cycle will begin at minimum duty cycle and ramp up slowly. This protection scheme allows the LED load to be hot connected and disconnected from the converter output without risk of damaging the circuit or of high voltages appearing at the output. Care should be taken however to avoid LED damage due to output capacitor discharge. An NTC thermistor at the output may be needed to limit the current surge. The overvoltage threshold is set by choosing the values of RZX1 and RZX2 according to the formula:

$$VOUT_{ov} = \frac{VOVTH \cdot N_s \cdot (RZX1 + RZX2)}{N_A \cdot RZX2} \quad [2]$$

The recommended over voltage threshold is 25% above the normal operating voltage of the LED load.

Operating with a secondary feedback circuit

In applications where accurate current regulation over a wide input voltage range or range of output voltages is required, the IRS2983 can be used in conjunction with a secondary sensing and feedback circuit.

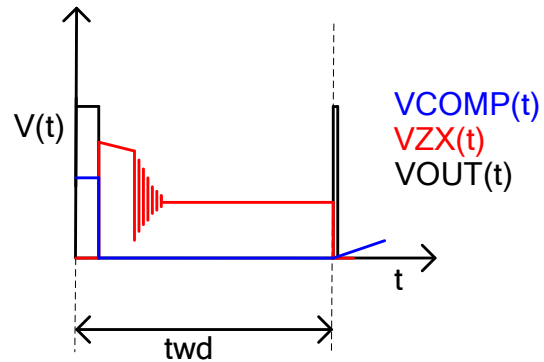

Figure 4: Overvoltage protection

The feedback circuit is usually fed through an opto isolator. This can be connected to the IRS2983 in the following way:

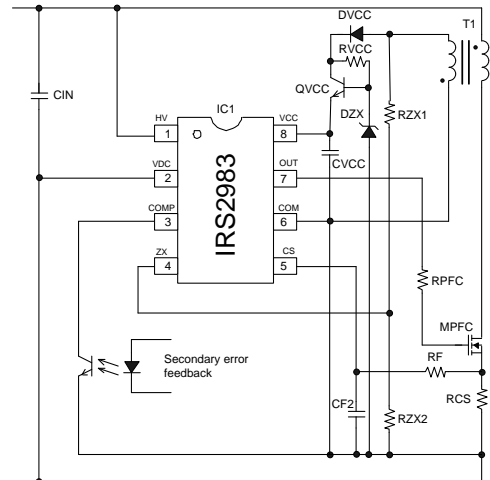

Figure 5: Secondary feedback circuit

A simple output voltage feedback scheme is shown in figure 5 to illustrate how the opto isolator is connected to the IRS2983 to create a feedback circuit. The VDC input is tied to COM leaving the internal multiplier output at zero so that the COMP output provides pull up. The opto isolator feedback pulls down on the COMP voltage to reduce the on time as the opto diode current is increased driven by a secondary error amplifier circuit. The HV startup is not disabled in this operating mode but draws only micro current if VCC is biased above 17V. This is easily done by using a series pass transistor with the base biased with an 18V zener diode to supply VCC.

Package Details

DIM	INCHES		MILLIMETERS	
	MIN	MAX	MIN	MAX
A	.0532	.0688	1.35	1.75
A1	.0040	.0098	0.10	0.25
b	.013	.020	0.33	0.51
c	.0075	.0098	0.19	0.25
D	.189	.1968	4.80	5.00
E	.1497	.1574	3.80	4.00
e	.050 BASIC		1.27 BASIC	
e 1	.025 BASIC		0.635 BASIC	
H	.2284	.2440	5.80	6.20
K	.0099	.0196	0.25	0.50
L	.016	.050	0.40	1.27
y	0°	8°	0°	8°

NOTES:

1. DIMENSIONING & TOLERANCING PER ASME Y14.5M-1994.
2. CONTROLLING DIMENSION: MILLIMETER
3. DIMENSIONS ARE SHOWN IN MILLIMETERS [INCHES].
4. OUTLINE CONFORMS TO JEDEC OUTLINE MS-012AA.
5. DIMENSION DOES NOT INCLUDE MOLD PROTRUSIONS. MOLD PROTRUSIONS NOT TO EXCEED 0.15 [0.06].
6. DIMENSION DOES NOT INCLUDE MOLD PROTRUSIONS. MOLD PROTRUSIONS NOT TO EXCEED 0.25 [0.10].
7. DIMENSION IS THE LENGTH OF LEAD FOR SOLDERING TO A SUBSTRATE.

8-Lead SOIC

01-6027
01-0021 11 (MS-012AA)

Tape and Reel Details

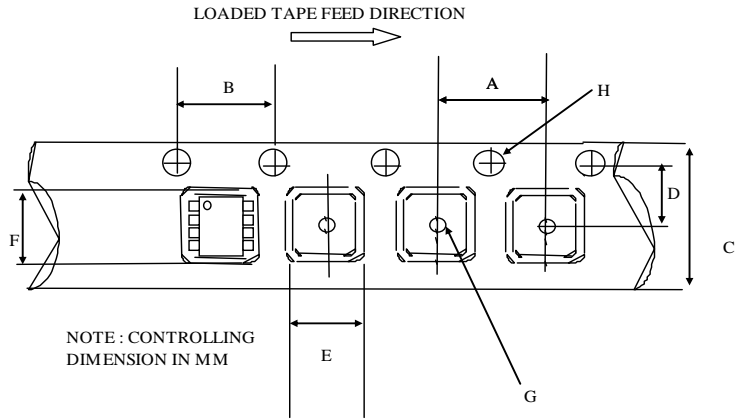

CARRIER TAPE DIMENSION FOR 8SOICN

Code	Metric		Imperial	
	Min	Max	Min	Max
A	7.90	8.10	0.311	0.318
B	3.90	4.10	0.153	0.161
C	11.70	12.30	0.46	0.484
D	5.45	5.55	0.214	0.218
E	6.30	6.50	0.248	0.255
F	5.10	5.30	0.200	0.208
G	1.50	n/a	0.059	n/a
H	1.50	1.60	0.059	0.062

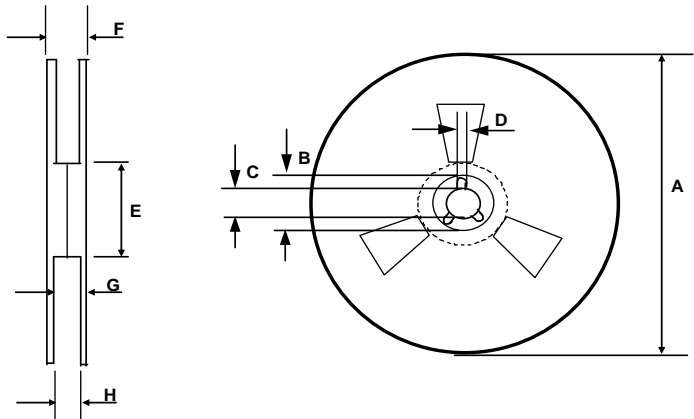

REEL DIMENSIONS FOR 8SOICN

Code	Metric		Imperial	
	Min	Max	Min	Max
A	329.60	330.25	12.976	13.001
B	20.95	21.45	0.824	0.844
C	12.80	13.20	0.503	0.519
D	1.95	2.45	0.767	0.096
E	98.00	102.00	3.858	4.015
F	n/a	18.40	n/a	0.724
G	14.50	17.10	0.570	0.673
H	12.40	14.40	0.488	0.566

Part Marking Information

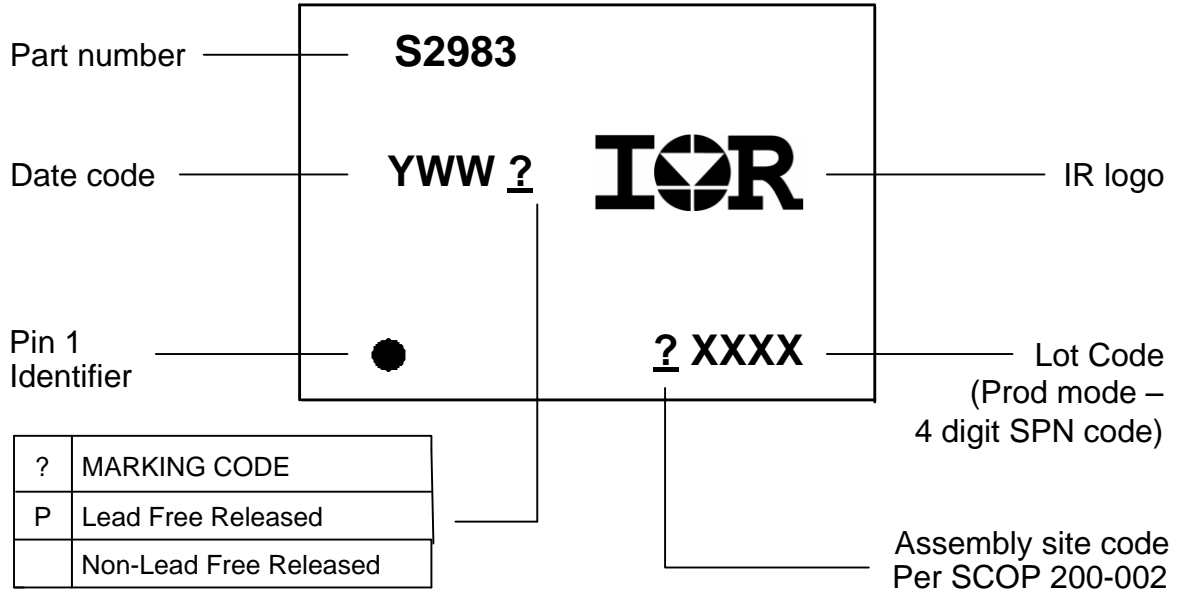

The information provided in this document is believed to be accurate and reliable. However, International Rectifier assumes no responsibility for the consequences of the use of this information. International Rectifier assumes no responsibility for any infringement of patents or of other rights of third parties which may result from the use of this information. No license is granted by implication or otherwise under any patent or patent rights of International Rectifier. The specifications mentioned in this document are subject to change without notice. This document supersedes and replaces all information previously supplied.

For technical support, please contact IR's Technical Assistance Center
<http://www.irf.com/technical-info/>

WORLD HEADQUARTERS:
 233 Kansas St., El Segundo, California 90245
 Tel: (310) 252-7105