

## ICL3238E

±15kV ESD Protected, +3V to +5.5V, 10nA, 250kbps, RS-232 Transceiver with Enhanced Automatic Powerdown

FN6012  
Rev 3.00  
July 2004

The Intersil ICL3238E contains 3.0V to 5.5V powered RS-232 transmitters/receivers which meet EIA/TIA-232 and V.28/V.24 specifications, even at  $V_{CC} = 3.0V$ . Additionally, it provides ±15kV ESD protection (IEC61000-4-2 Air Gap and Human Body Model) on transmitter outputs and receiver inputs (RS-232 pins). Targeted applications are cell phones, Palmtops, and data cables where the low operational, and even lower standby, power consumption is critical. Efficient on-chip charge pumps, coupled with manual and enhanced automatic powerdown functions, reduce the standby supply current to a 10nA trickle. Small footprint packaging, and the use of small, low value capacitors ensure board space savings as well. Data rates greater than 250kbps are guaranteed at worst case load conditions providing compatibility with popular PC communication software.

The ICL3238E is a 5 driver, 3 receiver device optimized for DCE applications with full hardware handshaking. It also includes a noninverting always-active receiver for RING INDICATOR monitoring.

This device, features an **enhanced automatic powerdown** function which powers down the on-chip power-supply and driver circuits. This occurs when all receiver and transmitter inputs detect no signal transitions for a period of 30s. The ICL3238E powers back up, automatically, whenever it senses a transition on any transmitter or receiver input.

The transmitter and logic inputs include active feedback resistors that retain the input state once driven to a valid logic level.

Table 1 summarizes the features of the ICL3238E, while Application Note AN9863 summarizes the features of each device comprising the ICL32XXE 3V family.

### Features

- Pb-Free Available as an Option (see Ordering Info)
- ESD Protection for RS-232 I/O Pins to ±15kV (IEC61000)
- Active Feedback Resistors on  $T_X$  and Logic Inputs.
- Manual and Enhanced Automatic Powerdown Features
- Pin Compatible Replacement for MAX3238E, MAX3238, SP3238E
- Meets EIA/TIA-232 and V.28/V.24 Specifications at 3V
- RS-232 Compatible Outputs at 2.7V Supply
- Flow Through Pinout
- Latch-Up Free
- On-Chip Voltage Converters Require Only Four External Capacitors
- Receiver and Transmitter Hysteresis For Improved Noise Immunity
- Guaranteed Minimum Data Rate . . . . . 250kbps
- Guaranteed Minimum Slew Rate . . . . . 6V/μs
- Wide Power Supply Range . . . . . Single +3V to +5.5V
- Low Supply Current in Powerdown State. . . . . 10nA

### Applications

- Any System Requiring RS-232 Communication Ports
  - Battery Powered, Hand-Held, and Portable Equipment
  - Data Cradles
  - Modems, Printers and other Peripherals
  - Cellular/Mobile Phones, Data Cables

TABLE 1. SUMMARY OF FEATURES

PART NUMBER	NO. OF Tx.	NO. OF Rx.	NO. OF MONITOR Rx. (R <sub>OUTB</sub> )	DATA RATE (kbps)	Rx. ENABLE FUNCTION?	READY OUTPUT?	MANUAL POWER-DOWN?	ENHANCED AUTOMATIC POWERDOWN FUNCTION?
ICL3238E	5	3	1	250	No	No	Yes	Yes

## Pinout

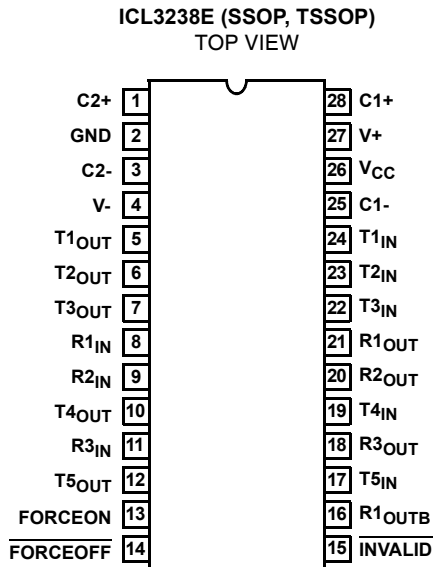

## Ordering Information

PART NO.	TEMP. RANGE (°C)	PACKAGE	PKG. DWG. #
ICL3238ECA	0 to 70	28 Ld SSOP	M28.209
ICL3238ECA-T	0 to 70	28 Ld SSOP Tape and Reel	M28.209
ICL3238ECAZ (Note)	0 to 70	28 Ld SSOP (Pb-Free)	M28.209
ICL3238ECAZ-T (Note)	0 to 70	28 Ld SSOP Tape and Reel (Pb-Free)	M28.209
ICL3238EIA	-40 to 85	28 Ld SSOP	M28.209
ICL3238EIA-T	-40 to 85	28 Ld SSOP Tape and Reel	M28.209
ICL3238EIAZ (Note)	-40 to 85	28 Ld SSOP (Pb-Free)	M28.209
ICL3238EIAZ-T (Note)	-40 to 85	28 Ld SSOP Tape and Reel (Pb-Free)	M28.209
ICL3238EIV-T	-40 to 85	28 Ld TSSOP Tape and Reel	M28.173
ICL3238EIVZ-T (Note)	-40 to 85	28 Ld TSSOP Tape and Reel (Pb-Free)	M28.173

NOTE: Intersil Pb-free products employ special Pb-free material sets; molding compounds/die attach materials and 100% matte tin plate termination finish, which is compatible with both SnPb and Pb-free soldering operations. Intersil Pb-free products are MSL classified at Pb-free peak reflow temperatures that meet or exceed the Pb-free requirements of IPC/JEDEC J Std-020B.

## Pin Descriptions

PIN	FUNCTION
V <sub>CC</sub>	System Power Supply Input (3.0V to 5.5V).
V+	Internally Generated Positive Transmitter Supply (+5.5V).
V-	Internally Generated Negative Transmitter Supply (-5.5V).
GND	Ground Connection.
C1+	External Capacitor (Voltage Doubler) is connected to this lead.
C1-	External Capacitor (Voltage Doubler) is connected to this lead.
C2+	External Capacitor (Voltage Inverter) is connected to this lead.
C2-	External Capacitor (Voltage Inverter) is connected to this lead.
T <sub>IN</sub>	TTL/CMOS Compatible Transmitter Inputs (Note 1).
T <sub>OUT</sub>	±15kV ESD Protected, RS-232 Level (Nominally ±5.5V) Transmitter Outputs.
R <sub>IN</sub>	±15kV ESD Protected, RS-232 Compatible Receiver Inputs.
R <sub>OUT</sub>	TTL/CMOS Level Receiver Outputs.
R <sub>OUTB</sub>	TTL/CMOS Level, Noninverting, Always Enabled Receiver Outputs.
INVALID	Active Low Output that indicates if no valid RS-232 levels are present on any receiver input.
FORCEOFF	Active Low to Shut Down Transmitters and On-Chip Power Supply. This overrides any automatic circuitry and FORCEON (see Table 2, Note 1).
FORCEON	Active High Input to override automatic powerdown circuitry thereby keeping transmitters active. (FORCEOFF must be high, Note 1).

### NOTE:

- These input pins incorporate positive feedback resistors. Once the input is driven to a valid logic level, the feedback resistor maintains that logic level until V<sub>CC</sub> is removed. Unused transmitter inputs may be left unconnected by the user.

Typical Operating Circuit

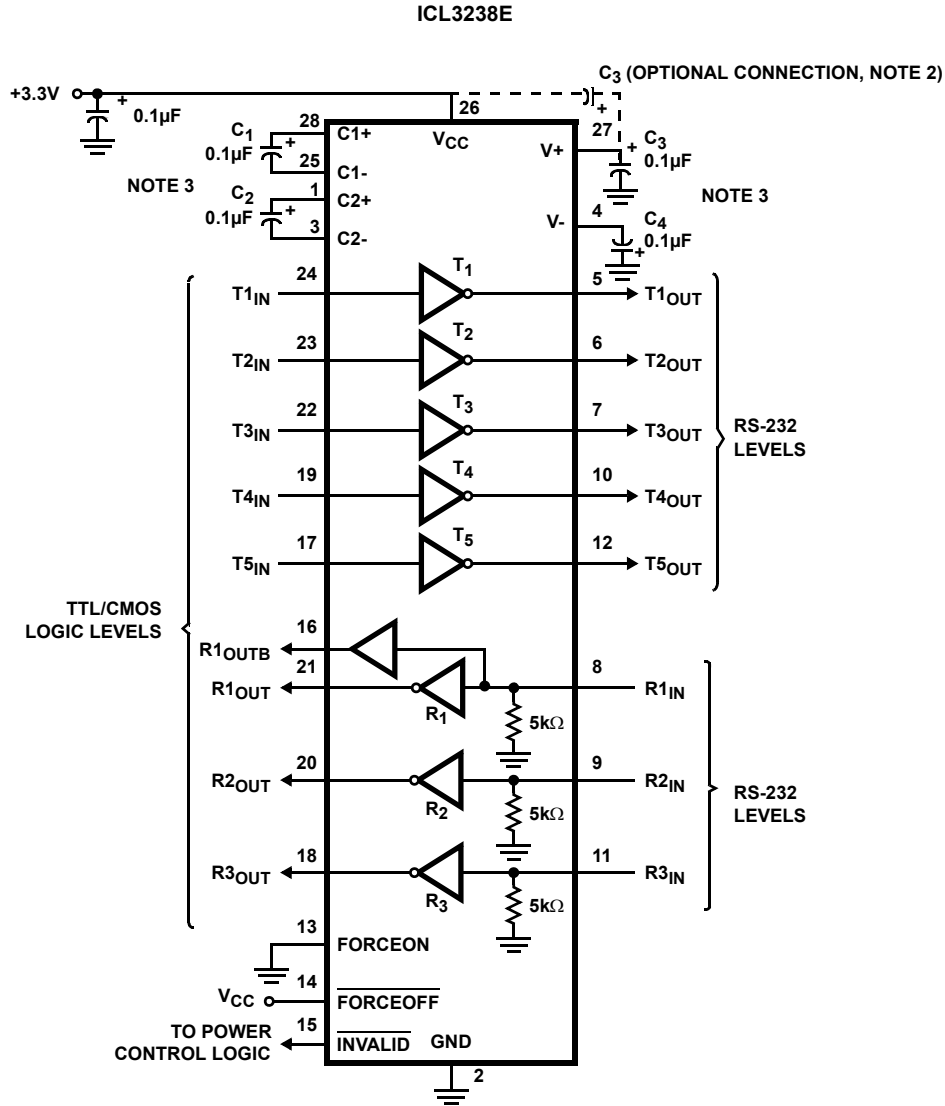

NOTES:

- 2. The negative terminal of C<sub>3</sub> can be connected to either V<sub>CC</sub> or GND.
- 3. For V<sub>CC</sub> = 3.15V (3.3V -5%), use C<sub>1</sub> - C<sub>4</sub> = 0.1µF or greater. For V<sub>CC</sub> = 3.0V (3.3V -10%), use C<sub>1</sub> - C<sub>4</sub> = 0.22µF.

**Absolute Maximum Ratings**

V <sub>CC</sub> to Ground	-0.3V to 6V
V <sub>+</sub> to Ground	-0.3V to 7V
V <sub>-</sub> to Ground	+0.3V to -7V
V <sub>+</sub> to V <sub>-</sub>	14V
Input Voltages	
T <sub>IN</sub> , FORCEOFF, FORCEON	-0.3V to 6V
R <sub>IN</sub>	±25V
Output Voltages	
T <sub>OUT</sub>	±13.2V
R <sub>OUT</sub> , INVALID	-0.3V to V <sub>CC</sub> +0.3V
Short Circuit Duration	
T <sub>OUT</sub>	Continuous
ESD Rating	See Specification Table

**Thermal Information**

Thermal Resistance (Typical, Note 4)	θ <sub>JA</sub> (°C/W)
28 Ld TSSOP Package	100
28 Ld SSOP Package	110
Maximum Junction Temperature (Plastic Package)	150°C
Maximum Storage Temperature Range	-65°C to 150°C
Maximum Lead Temperature (Soldering 10s) (Lead Tips Only)	300°C

**Operating Conditions**

Temperature Range	
ICL3238ECX	0°C to 70°C
ICL3238EIX	-40°C to 85°C

**CAUTION:** Stresses above those listed in "Absolute Maximum Ratings" may cause permanent damage to the device. This is a stress only rating and operation of the device at these or any other conditions above those indicated in the operational sections of this specification is not implied.

**NOTE:**

4. θ<sub>JA</sub> is measured with the component mounted on a low effective thermal conductivity test board in free air. See Tech Brief TB379 for details.

**Electrical Specifications** Test Conditions: V<sub>CC</sub> = 3.15V to 5.5V, C<sub>1</sub> - C<sub>4</sub> = 0.1μF; V<sub>CC</sub> = 3V, C<sub>1</sub> - C<sub>4</sub> = 0.22μF; Unless Otherwise Specified. Typical values are at T<sub>A</sub> = 25°C

PARAMETER	TEST CONDITIONS	TEMP (°C)	MIN	TYP	MAX	UNITS	
<b>DC CHARACTERISTICS</b>							
Supply Current, Automatic Powerdown	All R <sub>IN</sub> Open, FORCEON = GND, FORCEOFF = V <sub>CC</sub>	25	-	10	300	nA	
Supply Current, Powerdown	FORCEOFF = GND	25	-	10	300	nA	
Supply Current, Automatic Powerdown Disabled	All Outputs Unloaded, FORCEON = FORCEOFF = V <sub>CC</sub>	25	-	0.3	1.0	mA	
<b>LOGIC AND TRANSMITTER INPUTS AND RECEIVER OUTPUTS</b>							
Input Logic Threshold Low	T <sub>IN</sub> Active	Full	-	-	0.8	V	
	T <sub>IN</sub> , FORCEON, FORCEOFF Wake up Threshold	V <sub>CC</sub> = 3.3V	Full	-	-	0.8	V
		V <sub>CC</sub> = 5.0V	Full	-	-	0.8	V
Input Logic Threshold High	T <sub>IN</sub> Active	V <sub>CC</sub> = 3.6V	Full	2.0	-	-	V
	T <sub>IN</sub> , FORCEON, FORCEOFF Wake up Threshold	V <sub>CC</sub> = 3.3V	Full	2.0	-	-	V
		V <sub>CC</sub> = 5.0V	Full	2.4	-	-	V
Input Leakage Current	T <sub>IN</sub> , FORCEON, FORCEOFF, V <sub>IN</sub> = 0V or V <sub>CC</sub> (Note 5)	Full	-	±0.01	±1.0	μA	
Output Leakage Current	FORCEOFF = GND	Full	-	±0.05	±10	μA	
Output Voltage Low	I <sub>OUT</sub> = 1.0mA	Full	-	-	0.4	V	
Output Voltage High	I <sub>OUT</sub> = -1.0mA	Full	V <sub>CC</sub> - 0.6	V <sub>CC</sub> - 0.1	-	V	
<b>RECEIVER INPUTS</b>							
Input Voltage Range		Full	-25	-	25	V	
Input Threshold Low	V <sub>CC</sub> = 3.3V	Full	0.6	1.2	-	V	
	V <sub>CC</sub> = 5.0V	Full	0.8	1.5	-	V	
Input Threshold High	V <sub>CC</sub> = 3.3V	Full	-	1.5	2.4	V	
	V <sub>CC</sub> = 5.0V	Full	-	1.8	2.4	V	
Input Hysteresis		25	-	0.6	-	V	
Input Resistance		25	3	5	7	kΩ	

**Electrical Specifications** Test Conditions:  $V_{CC} = 3.15V$  to  $5.5V$ ,  $C_1 - C_4 = 0.1\mu F$ ;  $V_{CC} = 3V$ ,  $C_1 - C_4 = 0.22\mu F$ ; Unless Otherwise Specified. Typicals are at  $T_A = 25^\circ C$  (Continued)

PARAMETER	TEST CONDITIONS	TEMP (°C)	MIN	TYP	MAX	UNITS	
<b>ENHANCED AUTOMATIC POWERDOWN</b> (FORCEON = GND, FORCEOFF = $V_{CC}$ )							
Receiver Input Thresholds to $\overline{INVALID}$ High	(Figure 6)	Full	-2.7	-	2.7	V	
Receiver Input Thresholds to $\overline{INVALID}$ Low	(Figure 6)	Full	-0.3	-	0.3	V	
$\overline{INVALID}$ Output Voltage Low	$I_{OUT} = 1.0mA$	Full	-	-	0.4	V	
$\overline{INVALID}$ Output Voltage High	$I_{OUT} = -1.0mA$	Full	$V_{CC}-0.6$	-	-	V	
Receiver Positive or Negative Threshold to $\overline{INVALID}$ High Delay ( $t_{INVH}$ )		25	-	0.3	-	$\mu s$	
Receiver Positive or Negative Threshold to $\overline{INVALID}$ Low Delay ( $t_{INVL}$ )		25	-	60	-	$\mu s$	
Receiver or Transmitter Edge to Transmitters Enabled Delay ( $t_{WU}$ )	(Note 6)	25	-	25	-	$\mu s$	
Receiver or Transmitter Edge to Transmitters Disabled Delay ( $t_{AUTOPWDN}$ )	(Note 6)	Full	15	30	60	s	
<b>TRANSMITTER OUTPUTS</b>							
Output Voltage Swing	All Transmitter Outputs Loaded with $3k\Omega$ to Ground	Full	$\pm 5.0$	$\pm 5.4$	-	V	
Output Resistance	$V_{CC} = V_+ = V_- = 0V$ , Transmitter Output = $\pm 2V$	Full	300	10M	-	$\Omega$	
Output Short-Circuit Current		Full	-	$\pm 35$	$\pm 60$	mA	
Output Leakage Current	$V_{OUT} = \pm 12V$ , $V_{CC} = 0V$ or $3V$ to $5.5V$ , Automatic Powerdown or FORCEOFF = GND	Full	-	-	$\pm 25$	$\mu A$	
<b>TIMING CHARACTERISTICS</b>							
Maximum Data Rate	$R_L = 3k\Omega$ , $C_L = 1000pF$ , One Transmitter Switching	Full	250	500	-	kbps	
Receiver Propagation Delay	Receiver Input to Receiver Output, $C_L = 150pF$	$t_{PHL}$	25	-	0.15	-	$\mu s$
		$t_{PLH}$	25	-	0.15	-	$\mu s$
Receiver Output Enable Time	Normal Operation	25	-	150	-	ns	
Receiver Output Disable Time	Normal Operation	25	-	300	-	ns	
Transmitter Skew	$t_{PHL} - t_{PLH}$	25	-	50	-	ns	
Receiver Skew	$t_{PHL} - t_{PLH}$	25	-	50	-	ns	
Transition Region Slew Rate	$V_{CC} = 3.3V$ , $R_L = 3k\Omega$ to $7k\Omega$ , Measured From $3V$ to $-3V$ or $-3V$ to $3V$	$C_L = 150pF$ to $1000pF$	25	6	15	30	V/ $\mu s$
		$C_L = 150pF$ to $2500pF$	25	4	12	30	V/ $\mu s$
<b>ESD PERFORMANCE</b>							
RS-232 Pins ( $T_{OUT}$ , $R_{IN}$ )	IEC61000-4-2 Air Gap Discharge	25	-	$\pm 15$	-	kV	
	IEC61000-4-2 Contact Discharge	25	-	$\pm 8$	-	kV	
	Human Body Model	25	-	$\pm 15$	-	kV	
All Other Pins	Human Body Model	25	-	$\pm 2.5$	-	kV	

## NOTES:

- These inputs utilize a positive feedback resistor. The input current is negligible when the input is at either supply rail.
- An "edge" is defined as a transition through the transmitter or receiver input thresholds.

## Detailed Description

ICL3238E operates from a single +3V to +5.5V supply, guarantees a 250kbps minimum data rate, requires only four small external 0.1 $\mu$ F (0.22 $\mu$ F for  $V_{CC} = 3.0V$ ) capacitors, features low power consumption, and meets all EIA/TIA-232 and V.28 specifications. The circuit is divided into three sections: The charge pump, the transmitters, and the receivers.

### Charge-Pump

Intersil's new ICL32XXE family utilizes regulated on-chip dual charge pumps as voltage doublers, and voltage inverters to generate  $\pm 5.5V$  transmitter supplies from a  $V_{CC}$  supply as low as 3.0V. This allows these devices to maintain RS-232 compliant output levels over the  $\pm 10\%$  tolerance range of 3.3V powered systems. The efficient on-chip power supplies require only four small, external 0.1 $\mu$ F capacitors for the voltage doubler and inverter functions at  $V_{CC} = 3.3V$ . See the "Capacitor Selection" section, and Table 3 for capacitor recommendations for other operating conditions. The charge pumps operate discontinuously (i.e., they turn off as soon as the V+ and V- supplies are pumped up to the nominal values), resulting in significant power savings.

### Transmitters

The transmitters are proprietary, low dropout, inverting drivers that translate TTL/CMOS inputs to EIA/TIA-232 output levels. Coupled with the on-chip  $\pm 5.5V$  supplies, these transmitters deliver true RS-232 levels over a wide range of single supply system voltages.

Transmitter outputs disable and assume a high impedance state when the device enters the powerdown mode (see Table 2). These outputs may be driven to  $\pm 12V$  when disabled.

All devices guarantee a 250kbps data rate for full load conditions (3k $\Omega$  and 1000pF),  $V_{CC} \geq 3.0V$ , with one transmitter operating at full speed. Under more typical conditions of  $V_{CC} \geq 3.3V$ ,  $R_L = 3k\Omega$ , and  $C_L = 250pF$ , one transmitter easily operates at 1Mbps.

Transmitter inputs incorporate an active positive feedback resistor that maintains the last driven input state in the absence of a forcing signal. Unused transmitter inputs may be left unconnected.

### Receivers

The ICL3238E contains both standard inverting, three-state receivers, and a single noninverting (monitor) receiver (denoted by the  $R_{OUTB}$  label) that is always active, regardless of the state of any control lines. Both receiver types convert RS-232 signals to CMOS output levels and accept inputs up to  $\pm 25V$  while presenting the required 3k $\Omega$  to 7k $\Omega$  input impedance (see Figure 1) even if the power is off ( $V_{CC} = 0V$ ). The receivers' Schmitt trigger input stage uses hysteresis to increase noise immunity and decrease errors due to slow input signal transitions.

The inverting receivers disable during forced (manual) powerdown, but not during automatic powerdown (see Table 2). Conversely, the monitor receiver remains active even

TABLE 2. POWERDOWN LOGIC TRUTH TABLE

RCVR OR XMTR EDGE WITHIN 30 SEC?	$\overline{\text{FORCEOFF}}$ INPUT	FORCEON INPUT	TRANSMITTER OUTPUTS	RECEIVER OUTPUTS	$R_{OUTB}$ OUTPUT	RS-232 LEVEL PRESENT AT RECEIVER INPUT?	$\overline{\text{INVALID}}$ OUTPUT	MODE OF OPERATION
No	H	H	Active	Active	Active	No	L	Normal Operation (Enhanced Auto Powerdown Disabled)
No	H	H	Active	Active	Active	Yes	H	
Yes	H	L	Active	Active	Active	No	L	Normal Operation (Enhanced Auto Powerdown Enabled)
Yes	H	L	Active	Active	Active	Yes	H	
No	H	L	High-Z	Active	Active	No	L	Powerdown Due to Enhanced Auto Powerdown Logic
No	H	L	High-Z	Active	Active	Yes	H	
X	L	X	High-Z	High-Z	Active	No	L	Manual Powerdown
X	L	X	High-Z	High-Z	Active	Yes	H	
<b><math>\overline{\text{INVALID DRIVING FORCEON AND FORCEOFF}}</math> (EMULATES AUTOMATIC POWERDOWN)</b>								
X	Note 7	Note 7	Active	Active	Active	Yes	H	Normal Operation
X	Note 7	Note 7	High-Z	High-Z	Active	No	L	Forced Auto Powerdown

NOTE:

7. Input is connected to  $\overline{\text{INVALID}}$  Output.

during manual powerdown making it extremely useful for RING INDICATOR monitoring. Standard receivers driving powered down peripherals must be disabled to prevent current flow through the peripheral's protection diodes (see Figures 2 and 3). This renders them useless for wake up functions, but the corresponding monitor receiver can be dedicated to this task as shown in Figure 3.

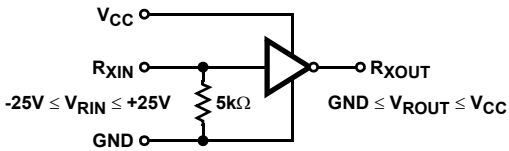

FIGURE 1. INVERTING RECEIVER CONNECTIONS

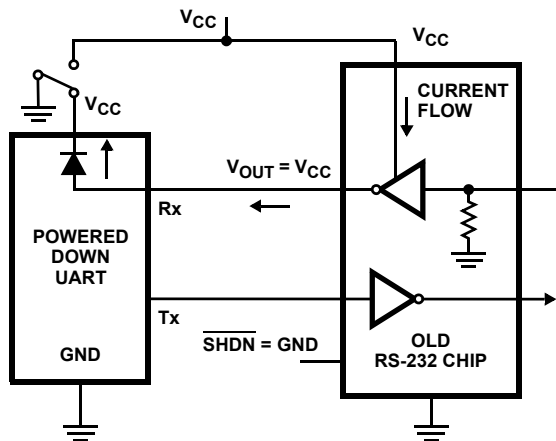

FIGURE 2. POWER DRAIN THROUGH POWERED DOWN PERIPHERAL

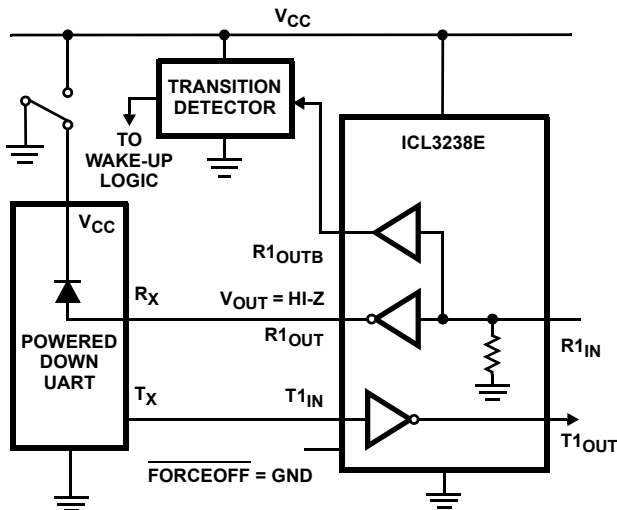

FIGURE 3. DISABLED RECEIVERS PREVENT POWER DRAIN

**Powerdown Functionality**

This 3V RS-232 interface device requires a nominal supply current of 0.3mA during normal operation (not in powerdown mode). This is considerably less than the 5mA to 11mA current

required by 5V RS-232 devices. The already low current requirement drops significantly when the device enters powerdown mode. In powerdown, supply current drops to 10nA, because the on-chip charge pump turns off (V+ collapses to VCC, V- collapses to GND), and the transmitter outputs three-state. This micro-power mode makes this device ideal for battery powered and portable applications.

**Software Controlled (Manual) Powerdown**

The ICL3238E allows the user to force the IC into the low power, standby state, and utilizes a two pin approach where the FORCEON and FORCEOFF inputs determine the IC's mode. For always enabled operation, FORCEON and FORCEOFF are both strapped high. To switch between active and powerdown modes, under logic or software control, only the FORCEOFF input need be driven. The FORCEON state isn't critical, as FORCEOFF dominates over FORCEON. Nevertheless, if strictly manual control over powerdown is desired, the user must strap FORCEON high to disable the enhanced automatic powerdown circuitry. ICL3238E inverting (standard) receiver outputs also disable when the device is in manual powerdown, thereby eliminating the possible current path through a shutdown peripheral's input protection diode (see Figures 2 and 3).

Connecting FORCEOFF and FORCEON together disables the enhanced automatic powerdown feature, enabling them to function as a manual SHUTDOWN input (see Figure 4).

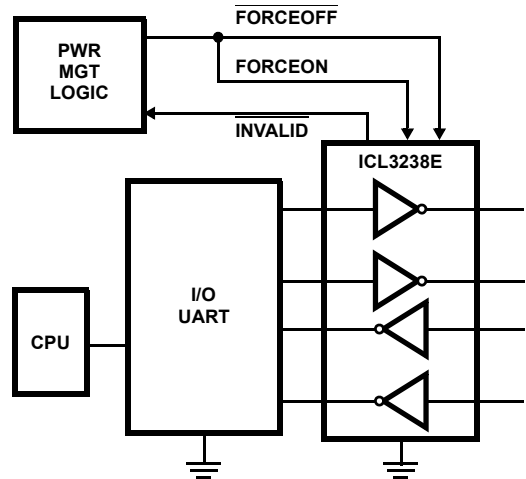

FIGURE 4. CONNECTIONS FOR MANUAL POWERDOWN WHEN NO VALID RECEIVER SIGNALS ARE PRESENT

With any of the above control schemes, the time required to exit powerdown, and resume transmission is only 25µs.

When using both manual and enhanced automatic powerdown (FORCEON = 0), the ICL3238E won't power up from manual powerdown until both FORCEOFF and FORCEON are driven high, or until a transition occurs on a receiver or transmitter input. Figure 5 illustrates a circuit for ensuring that the ICL3238E powers up as soon as FORCEOFF switches high. The rising edge of the Master Powerdown signal forces the

device to power up, and the ICL3238E returns to enhanced automatic powerdown mode an RC time constant after this rising edge. The time constant isn't critical, because the ICL3238E remains powered up for 30 seconds after the FORCEON falling edge, even if there are no signal transitions. This gives slow-to-wake systems (e.g., a mouse) plenty of time to start transmitting, and as long as it starts transmitting within 30 seconds both systems remain enabled.

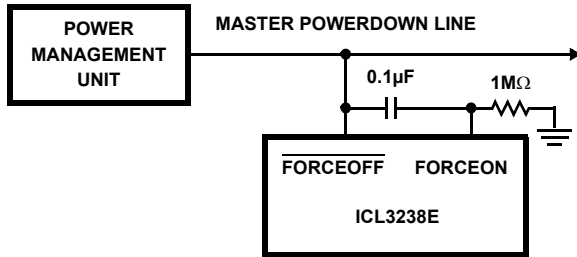

FIGURE 5. CIRCUIT TO ENSURE IMMEDIATE POWER UP WHEN EXITING FORCED POWERDOWN

**INVALID Output**

The  $\overline{\text{INVALID}}$  output always indicates (see Table 2) whether or not 30µs have elapsed with invalid RS-232 signals (see Figures 6 and 8) persisting on all of the receiver inputs, giving

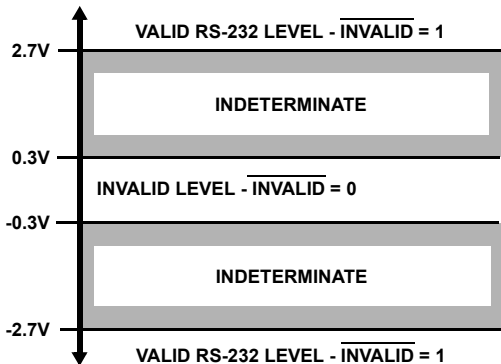

FIGURE 6. DEFINITION OF VALID RS-232 RECEIVER LEVELS

the user an easy way to determine when the interface block should power down. Invalid receiver levels occur whenever the driving peripheral's outputs are shut off (powered down) or when the RS-232 interface cable is disconnected. In the case of a disconnected interface cable where all the receiver inputs are floating (but pulled to GND by the internal receiver pull down resistors), the  $\overline{\text{INVALID}}$  logic detects the invalid levels and drives the output low. The power management logic then uses this indicator to power down the interface block. Reconnecting the cable restores valid levels at the receiver inputs,  $\overline{\text{INVALID}}$  switches high, and the power management logic wakes up the interface block.  $\overline{\text{INVALID}}$  can also be used to indicate the DTR or RING INDICATOR signal, as long as the other receiver inputs are floating, or driven to GND (as in the case of a powered down driver).

**Enhanced Automatic Powerdown**

Even greater power savings is available by using this device which features an *enhanced automatic* powerdown function. When the enhanced powerdown logic determines that no transitions have occurred on any of the transmitter nor receiver inputs for 30 seconds, the charge pump and transmitters powerdown, thereby reducing supply current to 10nA. The ICL3238E automatically powers back up whenever it detects a transition on one of these inputs. This automatic powerdown feature provides additional system power savings without changes to the existing operating system.

Enhanced automatic powerdown operates when the FORCEON input is low, and the  $\overline{\text{FORCEOFF}}$  input is high. Tying FORCEON high disables automatic powerdown, but manual powerdown is always available via the overriding  $\overline{\text{FORCEOFF}}$  input. Table 2 summarizes the enhanced automatic powerdown functionality.

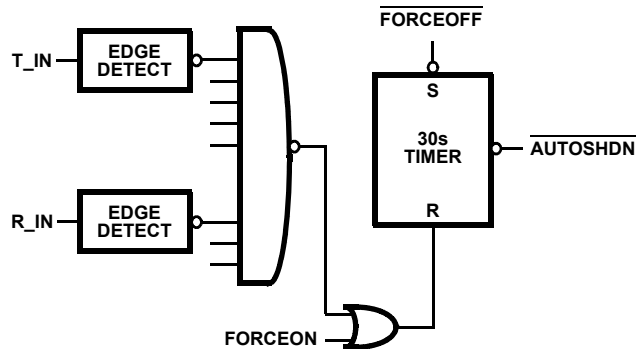

FIGURE 7. ENHANCED AUTOMATIC POWERDOWN LOGIC

Figure 7 illustrates the enhanced powerdown control logic. Note that once the ICL3238E enters powerdown (manually or automatically), the 30 second timer remains timed out (set), keeping the ICL3238E powered down until FORCEON transitions high, or until a transition occurs on a receiver or transmitter input.

The  $\overline{\text{INVALID}}$  output signal switches low to indicate that invalid levels have persisted on all of the receiver inputs for more than 60µs (see Figure 8), but this has no direct effect on the state of the ICL3238E (see the next sections for methods of utilizing  $\overline{\text{INVALID}}$  to power down the device).  $\overline{\text{INVALID}}$  switches high 1µs after detecting a valid RS-232 level on a receiver input.  $\overline{\text{INVALID}}$  operates in all modes (forced or automatic powerdown, or forced on), so it is also useful for systems employing manual powerdown circuitry. The time to recover from automatic powerdown mode is typically 25µs.



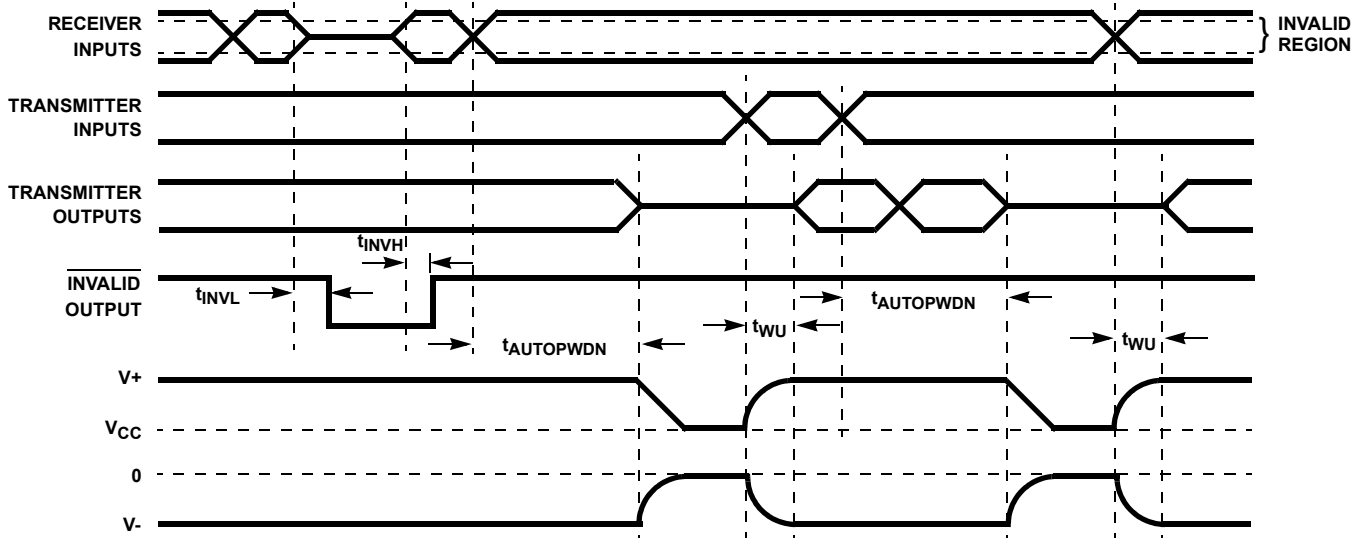

FIGURE 8. ENHANCED AUTOMATIC POWERDOWN, AND INVALID TIMING DIAGRAMS

**Emulating Standard Automatic Powerdown**

If enhanced automatic powerdown isn't desired, the user can implement the standard automatic powerdown feature (mimics the function on the ICL3221, ICL3223, ICL3243E) by connecting the INVALID output to the FORCEON and FORCEOFF inputs, as shown in Figure 9. After 60µs of invalid receiver levels, INVALID switches low and drives the ICL3238E into a forced powerdown condition. INVALID switches high as soon as a receiver input senses a valid RS-232 level, forcing the ICL3238E to power on. See the "INVALID DRIVING FORCEON AND FORCEOFF" section of Table 2 for an operational summary. This operational mode is perfect for handheld devices that communicate with another computer via a detachable cable. Detaching the cable allows the internal receiver pull-down resistors to pull the inputs to GND (an invalid RS-232 level), causing the 60µs timer to time-out and drive the IC into powerdown. Reconnecting the cable restores valid levels, causing the IC to power back up.

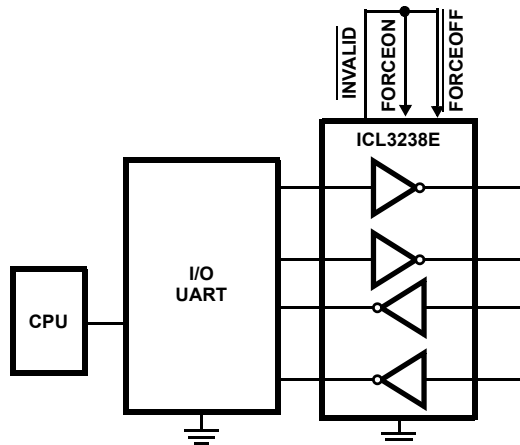

FIGURE 9. CONNECTIONS FOR AUTOMATIC POWERDOWN WHEN NO VALID RECEIVER SIGNALS ARE PRESENT

**Hybrid Automatic Powerdown Options**

For devices which communicate only through a detachable cable, connecting INVALID to FORCEOFF (with FORCEON = 0) may be a desirable configuration. While the cable is attached INVALID and FORCEOFF remain high, so the enhanced automatic powerdown logic powers down the RS-232 device whenever there is 30 seconds of inactivity on the receiver and transmitter inputs. Detaching the cable allows the receiver inputs to drop to an invalid level (GND), so INVALID switches low and forces the RS-232 device to power down. The ICL3238E remains powered down until the cable is reconnected (INVALID = FORCEOFF = 1) and a transition occurs on a receiver or transmitter input (see Figure 7). For immediate power up when the cable is reattached, connect FORCEON to FORCEOFF through a network similar to that shown in Figure 5.

**Capacitor Selection**

The charge pumps require 0.1µF, or greater, capacitors for 3.3V (5% tolerance) operation. For other supply voltages refer to Table 3 for capacitor values. Do not use values smaller than those listed in Table 3. Increasing the capacitor values (by a factor of 2) reduces ripple on the transmitter outputs and slightly reduces power consumption. C<sub>2</sub>, C<sub>3</sub>, and C<sub>4</sub> can be increased without increasing C<sub>1</sub>'s value, however, do not increase C<sub>1</sub> without also increasing C<sub>2</sub>, C<sub>3</sub>, and C<sub>4</sub> to maintain the proper ratios (C<sub>1</sub> to the other capacitors).

TABLE 3. REQUIRED CAPACITOR VALUES

V <sub>CC</sub> (V)	C <sub>1</sub> (µF)	C <sub>2</sub> , C <sub>3</sub> , C <sub>4</sub> (µF)
3.0 to 3.6 (3.3V ±10%)	0.22	0.22
3.15 to 3.6 (3.3V ±5%)	0.1	0.1
4.5 to 5.5	0.047	0.33
3.0 to 5.5	0.22	1

When using minimum required capacitor values, make sure that capacitor values do not degrade excessively with temperature. If in doubt, use capacitors with a larger nominal value. The capacitor's equivalent series resistance (ESR) usually rises at low temperatures and it influences the amount of ripple on V+ and V-.

**Power Supply Decoupling**

In most circumstances a 0.1µF bypass capacitor is adequate. In applications that are particularly sensitive to power supply noise, decouple V<sub>CC</sub> to ground with a capacitor of the same value as the charge-pump capacitor C<sub>1</sub>. Connect the bypass capacitor as close as possible to the IC.

**Operation Down to 2.7V**

ICL3238E transmitter outputs meet RS-562 levels (±3.7V), at full data rate, with V<sub>CC</sub> as low as 2.7V. RS-562 levels typically ensure interoperability with RS-232 devices.

**Transmitter Outputs when Exiting Powerdown**

Figure 10 shows the response of two transmitter outputs when exiting powerdown mode. As they activate, the two transmitter outputs properly go to opposite RS-232 levels, with no glitching, ringing, nor undesirable transients. Each transmitter is loaded with 3kΩ in parallel with 2500pF. Note that the transmitters enable only when the magnitude of the supplies exceed approximately 3V.

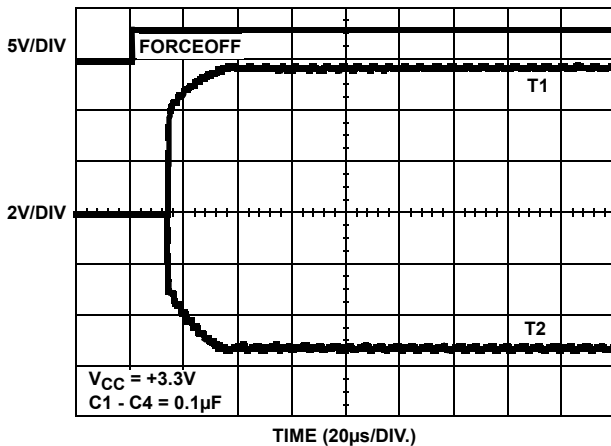

FIGURE 10. TRANSMITTER OUTPUTS WHEN EXITING POWERDOWN

**High Data Rates**

The ICL3238E maintains the RS-232 ±5V minimum transmitter output voltages even at high data rates. Figure 11 details a transmitter loopback test circuit, and Figure 12 illustrates the loopback test result at 120kbps. For this test, all transmitters were simultaneously driving RS-232 loads in parallel with 1000pF, at 120kbps. Figure 13 shows the loopback results for a single transmitter driving 1000pF and an RS-232 load at

250kbps. The static transmitters were also loaded with an RS-232 receiver.

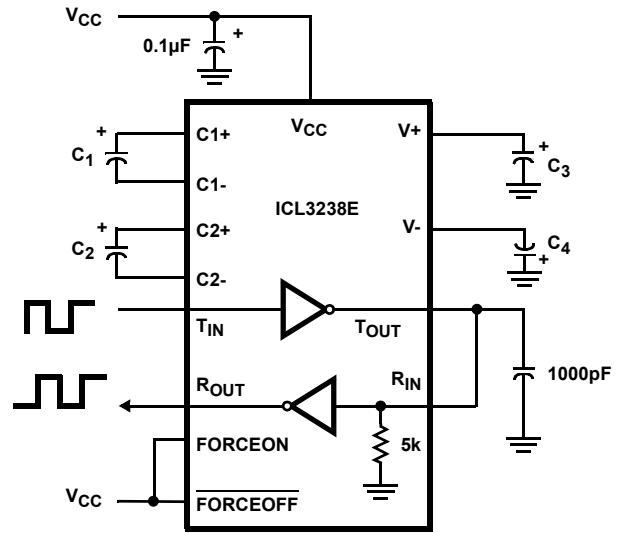

FIGURE 11. TRANSMITTER LOOPBACK TEST CIRCUIT

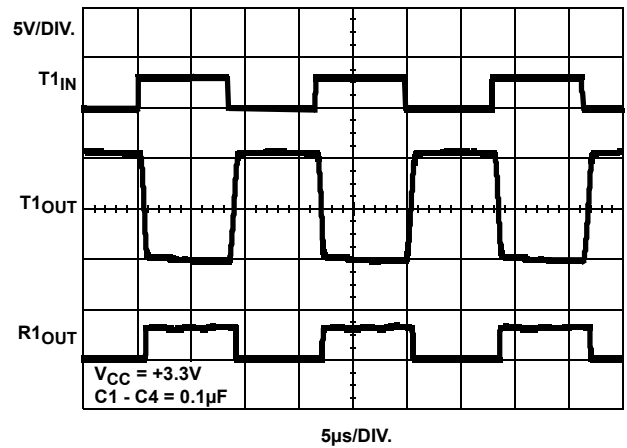

FIGURE 12. LOOPBACK TEST AT 120kbps

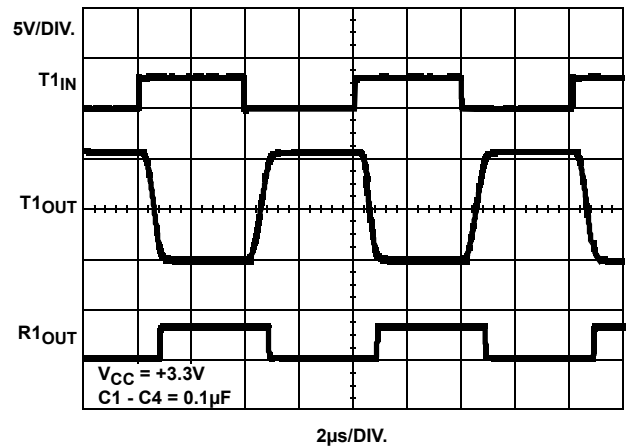

FIGURE 13. LOOPBACK TEST AT 250kbps

## Interconnection with 3V and 5V Logic

The ICL3238E directly interfaces with 5V CMOS and TTL logic families. Nevertheless, with the ICL32XX at 3.3V, and the logic supply at 5V, AC, HC, and CD4000 outputs can drive ICL32XX inputs, but ICL32XX outputs do not reach the minimum  $V_{IH}$  for these logic families. See Table 4 for more information.

**TABLE 4. LOGIC FAMILY COMPATIBILITY WITH VARIOUS SUPPLY VOLTAGES**

SYSTEM POWER-SUPPLY VOLTAGE (V)	V <sub>CC</sub> SUPPLY VOLTAGE (V)	COMPATIBILITY
3.3	3.3	Compatible with all CMOS families.
5	5	Compatible with all TTL and CMOS logic families.
5	3.3	Compatible with ACT and HCT CMOS, and with TTL. ICL32XX outputs are incompatible with AC, HC, and CD4000 CMOS inputs.

### ±15kV ESD Protection

All pins on ICL32XX devices include ESD protection structures, but the ICL32XXE family incorporates advanced structures which allow the RS-232 pins (transmitter outputs and receiver inputs) to survive ESD events up to ±15kV. The RS-232 pins are particularly vulnerable to ESD damage because they typically connect to an exposed port on the exterior of the finished product. Simply touching the port pins, or connecting a cable, can cause an ESD event that might destroy unprotected ICs. These new ESD structures protect the device whether or not it is powered up, protect without allowing any latchup mechanism to activate, and don't interfere with RS-232 signals as large as ±25V.

### Human Body Model (HBM) Testing

As the name implies, this test method emulates the ESD event delivered to an IC during human handling. The tester delivers the charge through a 1.5kΩ current limiting resistor, making the test less severe than the IEC61000 test which utilizes a 330Ω limiting resistor. The HBM method determines an ICs ability to withstand the ESD transients typically present during handling and manufacturing. Due to the random nature of these events, each pin is tested with respect to all other pins. The RS-232 pins on "E" family devices can withstand HBM ESD events to ±15kV.

### IEC61000-4-2 Testing

The IEC61000 test method applies to finished equipment, rather than to an individual IC. Therefore, the pins most likely to suffer an ESD event are those that are exposed to the outside world (the RS-232 pins in this case), and the IC is tested in its typical application configuration (power applied) rather than testing each pin-to-pin combination. The lower current limiting resistor coupled with the larger charge storage capacitor yields a test that is much more severe than the HBM test. The extra ESD protection built into this device's RS-232 pins allows the design of equipment meeting level 4 criteria without the need for additional board level protection on the RS-232 port.

### AIR-GAP DISCHARGE TEST METHOD

For this test method, a charged probe tip moves toward the IC pin until the voltage arcs to it. The current waveform delivered to the IC pin depends on approach speed, humidity, temperature, etc., so it is difficult to obtain repeatable results. The "E" device RS-232 pins withstand ±15kV air-gap discharges.

### CONTACT DISCHARGE TEST METHOD

During the contact discharge test, the probe contacts the tested pin before the probe tip is energized, thereby eliminating the variables associated with the air-gap discharge. The result is a more repeatable and predictable test, but equipment limits prevent testing devices at voltages higher than ±8kV. All "E" family devices survive ±8kV contact discharges on the RS-232 pins.

**Typical Performance Curves**  $V_{CC} = 3.3V, T_A = 25^\circ C$

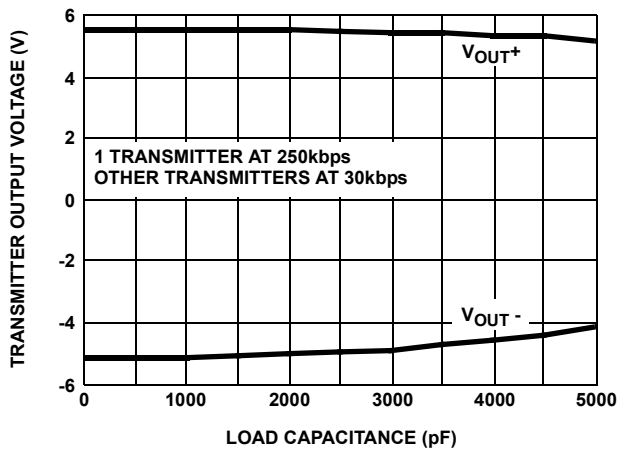

FIGURE 14. TRANSMITTER OUTPUT VOLTAGE vs LOAD CAPACITANCE

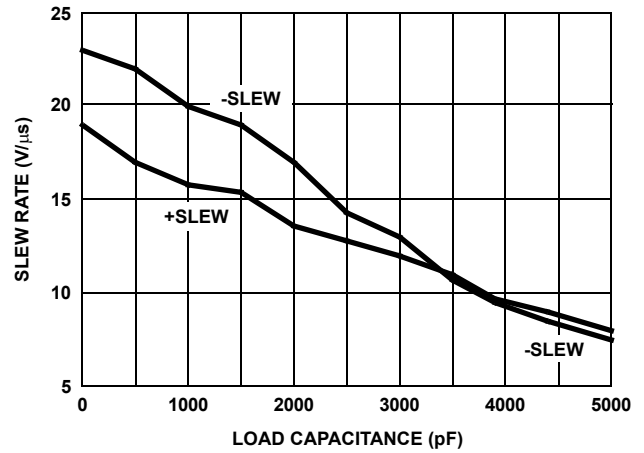

FIGURE 15. SLEW RATE vs LOAD CAPACITANCE

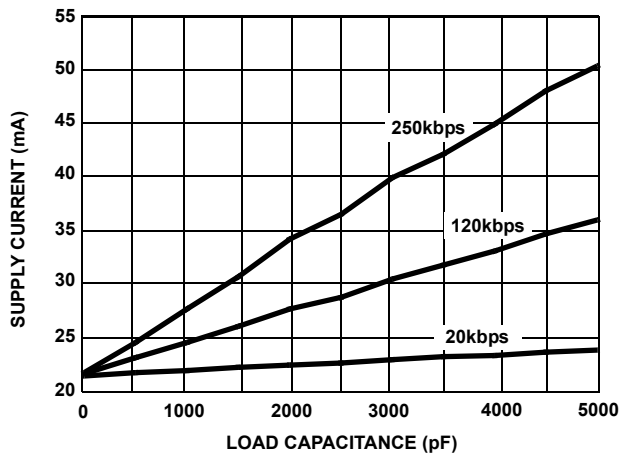

FIGURE 16. SUPPLY CURRENT vs LOAD CAPACITANCE WHEN TRANSMITTING DATA

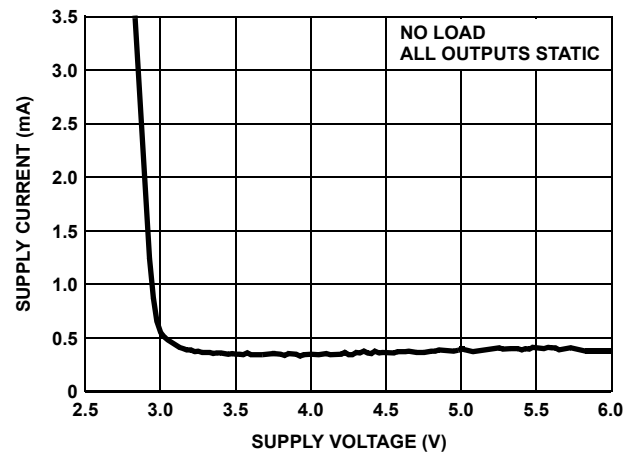

FIGURE 17. SUPPLY CURRENT vs SUPPLY VOLTAGE

**Die Characteristics**

**SUBSTRATE POTENTIAL (POWERED UP):**

GND

**TRANSISTOR COUNT:**

1235

**PROCESS:**

Si Gate CMOS

## Shrink Small Outline Plastic Packages (SSOP)

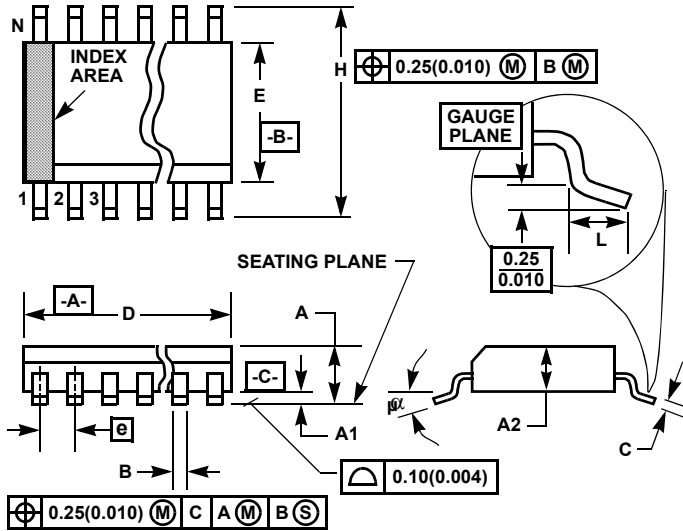

### M28.209 (JEDEC MO-150-AH ISSUE B) 28 LEAD SHRINK SMALL OUTLINE PLASTIC PACKAGE

SYMBOL	INCHES		MILLIMETERS		NOTES
	MIN	MAX	MIN	MAX	
A	-	0.078	-	2.00	-
A1	0.002	-	0.05	-	-
A2	0.065	0.072	1.65	1.85	-
B	0.009	0.014	0.22	0.38	9
C	0.004	0.009	0.09	0.25	-
D	0.390	0.413	9.90	10.50	3
E	0.197	0.220	5.00	5.60	4
e	0.026 BSC		0.65 BSC		-
H	0.292	0.322	7.40	8.20	-
L	0.022	0.037	0.55	0.95	6
N	28		28		7
$\alpha$	0°	8°	0°	8°	-

**NOTES:**

- Symbols are defined in the "MO Series Symbol List" in Section 2.2 of Publication Number 95.
- Dimensioning and tolerancing per ANSI Y14.5M-1982.
- Dimension "D" does not include mold flash, protrusions or gate burrs. Mold flash, protrusion and gate burrs shall not exceed 0.20mm (0.0078 inch) per side.
- Dimension "E" does not include interlead flash or protrusions. Interlead flash and protrusions shall not exceed 0.20mm (0.0078 inch) per side.
- The chamfer on the body is optional. If it is not present, a visual index feature must be located within the crosshatched area.
- "L" is the length of terminal for soldering to a substrate.
- "N" is the number of terminal positions.
- Terminal numbers are shown for reference only.
- Dimension "B" does not include dambar protrusion. Allowable dambar protrusion shall be 0.13mm (0.005 inch) total in excess of "B" dimension at maximum material condition.
- Controlling dimension: MILLIMETER. Converted inch dimensions are not necessarily exact.

Rev. 1 3/95

**Thin Shrink Small Outline Plastic Packages (TSSOP)**

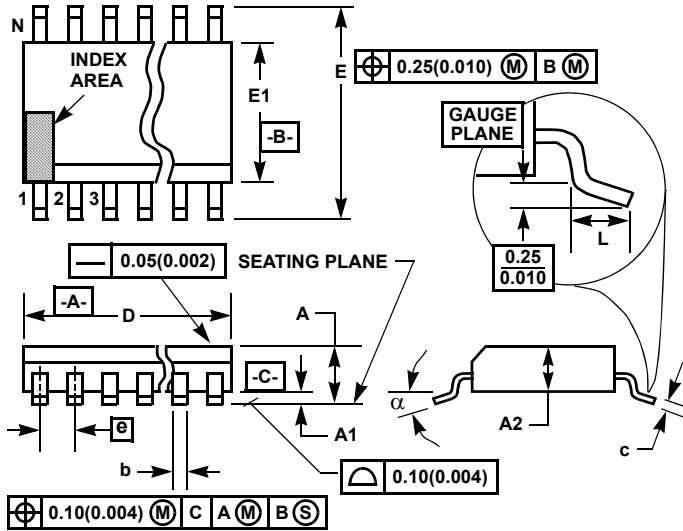

**M28.173**  
**28 LEAD THIN SHRINK SMALL OUTLINE PLASTIC PACKAGE**

SYMBOL	INCHES		MILLIMETERS		NOTES
	MIN	MAX	MIN	MAX	
A	-	0.047	-	1.20	-
A1	0.002	0.006	0.05	0.15	-
A2	0.031	0.051	0.80	1.05	-
b	0.0075	0.0118	0.19	0.30	9
c	0.0035	0.0079	0.09	0.20	-
D	0.378	0.386	9.60	9.80	3
E1	0.169	0.177	4.30	4.50	4
e	0.026 BSC		0.65 BSC		-
E	0.246	0.256	6.25	6.50	-
L	0.0177	0.0295	0.45	0.75	6
N	28		28		7
$\alpha$	0°	8°	0°	8°	-

Rev. 0 6/98

**NOTES:**

1. These package dimensions are within allowable dimensions of JEDEC MO-153-AE, Issue E.
2. Dimensioning and tolerancing per ANSI Y14.5M-1982.
3. Dimension "D" does not include mold flash, protrusions or gate burrs. Mold flash, protrusion and gate burrs shall not exceed 0.15mm (0.006 inch) per side.
4. Dimension "E1" does not include interlead flash or protrusions. Interlead flash and protrusions shall not exceed 0.15mm (0.006 inch) per side.
5. The chamfer on the body is optional. If it is not present, a visual index feature must be located within the crosshatched area.
6. "L" is the length of terminal for soldering to a substrate.
7. "N" is the number of terminal positions.
8. Terminal numbers are shown for reference only.
9. Dimension "b" does not include dambar protrusion. Allowable dambar protrusion shall be 0.08mm (0.003 inch) total in excess of "b" dimension at maximum material condition. Minimum space between protrusion and adjacent lead is 0.07mm (0.0027 inch).
10. Controlling dimension: MILLIMETER. Converted inch dimensions are not necessarily exact. (Angles in degrees)

© Copyright Intersil Americas LLC 2003-2004. All Rights Reserved.  
 All trademarks and registered trademarks are the property of their respective owners.

For additional products, see [www.intersil.com/en/products.html](http://www.intersil.com/en/products.html)

Intersil products are manufactured, assembled and tested utilizing ISO9001 quality systems as noted in the quality certifications found at [www.intersil.com/en/support/qualandreliability.html](http://www.intersil.com/en/support/qualandreliability.html)

*Intersil products are sold by description only. Intersil may modify the circuit design and/or specifications of products at any time without notice, provided that such modification does not, in Intersil's sole judgment, affect the form, fit or function of the product. Accordingly, the reader is cautioned to verify that datasheets are current before placing orders. Information furnished by Intersil is believed to be accurate and reliable. However, no responsibility is assumed by Intersil or its subsidiaries for its use; nor for any infringements of patents or other rights of third parties which may result from its use. No license is granted by implication or otherwise under any patent or patent rights of Intersil or its subsidiaries.*

For information regarding Intersil Corporation and its products, see [www.intersil.com](http://www.intersil.com)