

Silicon Carbide Power Schottky Diode

V_{RRM}	=	1200 V
$I_F (T_C = 25^\circ\text{C})$	=	12 A
$I_F (T_C \leq 150^\circ\text{C})$	=	5 A
Q_C	=	21 nC

Features

- Industry's leading low leakage currents
- 175 °C maximum operating temperature
- Temperature independent switching behavior
- Superior surge current capability
- Positive temperature coefficient of V_F
- Extremely fast switching speeds
- Superior figure of merit Q_C/I_F

Package

- RoHS Compliant

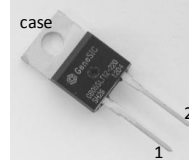
TO – 220AC

Advantages

- Low standby power losses
- Improved circuit efficiency (Lower overall cost)
- Low switching losses
- Ease of paralleling devices without thermal runaway
- Smaller heat sink requirements
- Low reverse recovery current
- Low device capacitance
- Low reverse leakage current at operating temperature

Applications

- Power Factor Correction (PFC)
- Switched-Mode Power Supply (SMPS)
- Solar Inverters
- Wind Turbine Inverters
- Motor Drives
- Induction Heating
- Uninterruptible Power Supply (UPS)
- High Voltage Multipliers

Maximum Ratings at $T_j = 175^\circ\text{C}$, unless otherwise specified

Parameter	Symbol	Conditions	Values	Unit
Repetitive peak reverse voltage	V_{RRM}		1200	V
Continuous forward current	I_F	$T_C = 25^\circ\text{C}$	12	A
Continuous forward current	I_F	$T_C \leq 150^\circ\text{C}$	5	A
RMS forward current	$I_{F(RMS)}$	$T_C \leq 150^\circ\text{C}$	8	A
Surge non-repetitive forward current, Half Sine Wave	$I_{F,SM}$	$T_C = 25^\circ\text{C}, t_p = 10\text{ ms}$	32	A
		$T_C = 150^\circ\text{C}, t_p = 10\text{ ms}$	26	A
Non-repetitive peak forward current	$I_{F,max}$	$T_C = 25^\circ\text{C}, t_p = 10\text{ }\mu\text{s}$	120	A
I^2t value	$\int i^2 dt$	$T_C = 25^\circ\text{C}, t_p = 10\text{ ms}$	5	A^2s
		$T_C = 150^\circ\text{C}, t_p = 10\text{ ms}$	3.4	A^2s
Power dissipation	P_{tot}	$T_C = 25^\circ\text{C}$	117	W
Operating and storage temperature	T_j, T_{stg}		-55 to 175	$^\circ\text{C}$

Electrical Characteristics at $T_j = 175^\circ\text{C}$, unless otherwise specified

Parameter	Symbol	Conditions	Values			Unit
			min.	typ.	max.	
Diode forward voltage	V_F	$I_F = 5\text{ A}, T_j = 25^\circ\text{C}$		1.6	1.9	V
		$I_F = 5\text{ A}, T_j = 175^\circ\text{C}$		2.6	3.0	
Reverse current	I_R	$V_R = 1200\text{ V}, T_j = 25^\circ\text{C}$		5	50	μA
		$V_R = 1200\text{ V}, T_j = 175^\circ\text{C}$		10	100	
Total capacitive charge	Q_C	$I_F \leq I_{F,MAX}$ $dI_F/dt = 200\text{ A}/\mu\text{s}$ $T_j = 175^\circ\text{C}$	$V_R = 400\text{ V}$	21		nC
	$V_R = 960\text{ V}$		35			
Switching time	t_s	$V_R = 1\text{ V}, f = 1\text{ MHz}, T_j = 25^\circ\text{C}$	$V_R = 400\text{ V}$	< 25		ns
			$V_R = 960\text{ V}$			
Total capacitance	C	$V_R = 1\text{ V}, f = 1\text{ MHz}, T_j = 25^\circ\text{C}$		260		pF
		$V_R = 400\text{ V}, f = 1\text{ MHz}, T_j = 25^\circ\text{C}$		25		
		$V_R = 1000\text{ V}, f = 1\text{ MHz}, T_j = 25^\circ\text{C}$		20		

Thermal Characteristics

Thermal resistance, junction - case	R_{thJC}	1.4	$^\circ\text{C}/\text{W}$
-------------------------------------	------------	-----	---------------------------

Mechanical Properties

Mounting torque	M	0.6	Nm
-----------------	---	-----	----

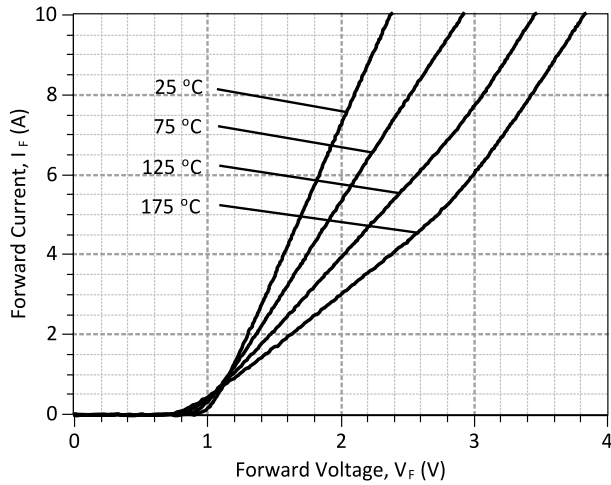

Figure 1: Typical Forward Characteristics

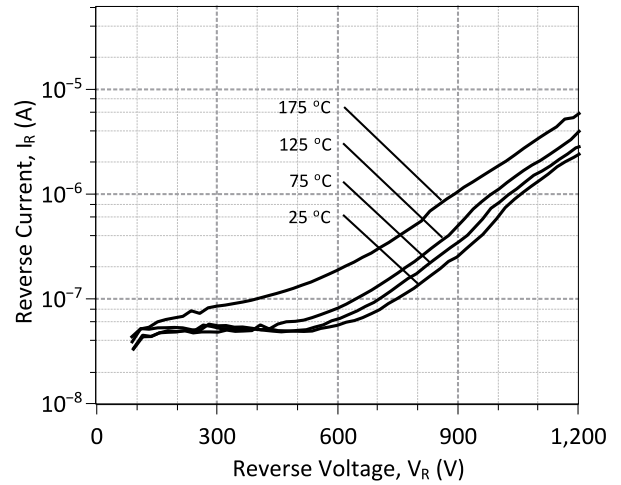

Figure 2: Typical Reverse Characteristics

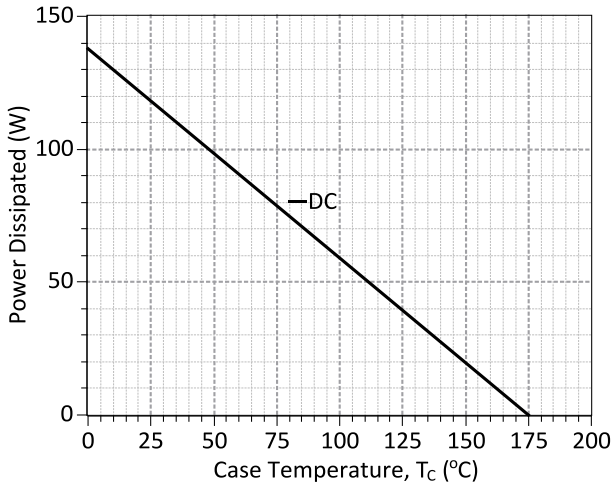
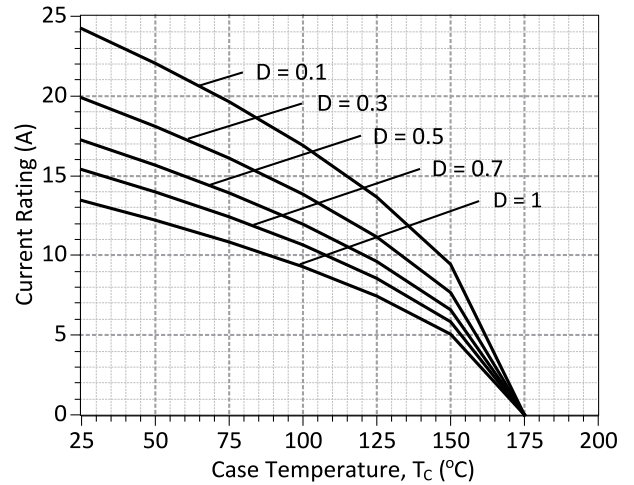

Figure 3: Power Derating Curve



**Figure 4: Current Derating Curves ($D = t_p/T$, $t_p = 400 \mu s$)
(Considering worst case Z_{th} conditions)**

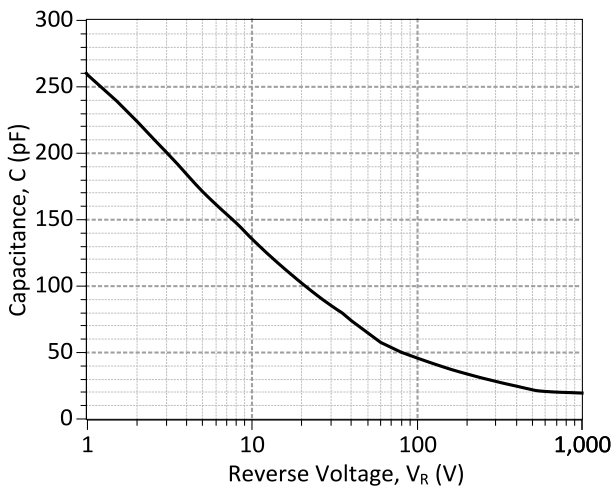

Figure 5: Typical Junction Capacitance vs Reverse Voltage Characteristics

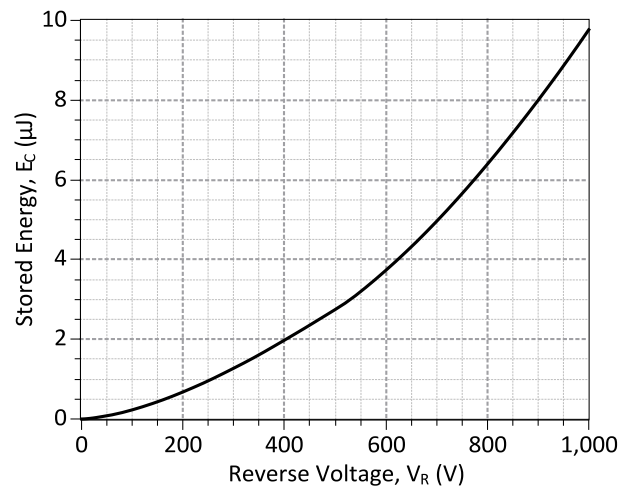

Figure 6: Typical Capacitive Energy vs Reverse Voltage Characteristics

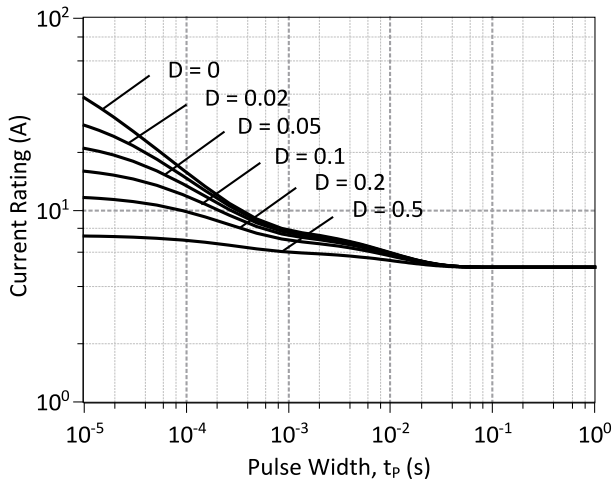

Figure 7: Current vs Pulse Duration Curves at $T_c = 155\text{ }^\circ\text{C}$

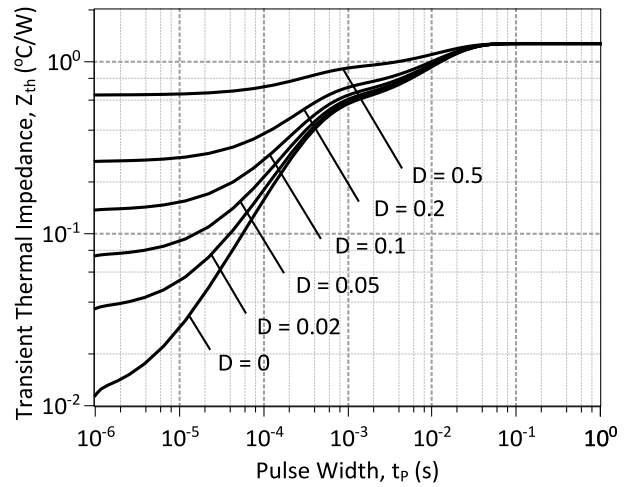
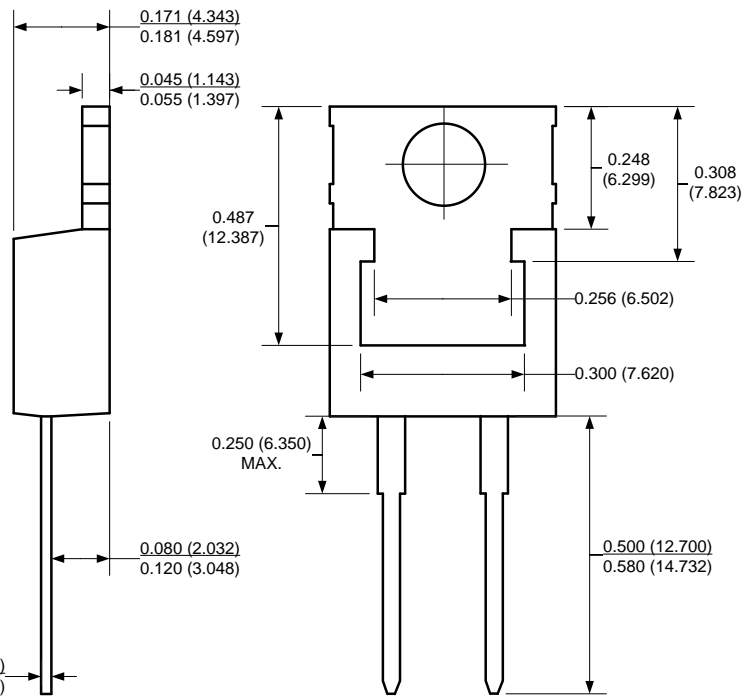
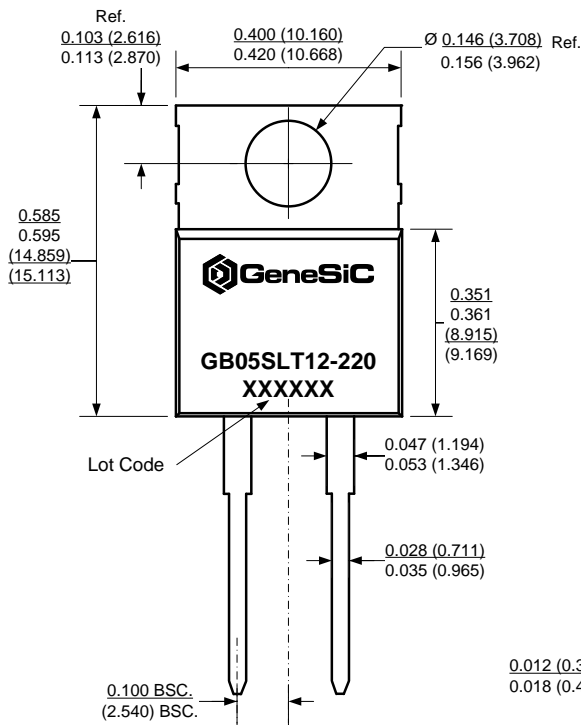

Figure 8: Transient Thermal Impedance

Package Dimensions:

TO-220AC

PACKAGE OUTLINE



NOTE

1. CONTROLLED DIMENSION IS INCH. DIMENSION IN BRACKET IS MILLIMETER.
2. DIMENSIONS DO NOT INCLUDE END FLASH, MOLD FLASH, MATERIAL PROTRUSIONS

Revision History

Date	Revision	Comments	Supersedes
2014/08/26	3	Updated Electrical Characteristics	
2013/02/05	2	Second generation update	
2012/05/22	1	Second generation release	
2010/12/14	0	Initial release	

Published by

GeneSiC Semiconductor, Inc.
43670 Trade Center Place Suite 155
Dulles, VA 20166

GeneSiC Semiconductor, Inc. reserves right to make changes to the product specifications and data in this document without notice.

GeneSiC disclaims all and any warranty and liability arising out of use or application of any product. No license, express or implied to any intellectual property rights is granted by this document.

Unless otherwise expressly indicated, GeneSiC products are not designed, tested or authorized for use in life-saving, medical, aircraft navigation, communication, air traffic control and weapons systems, nor in applications where their failure may result in death, personal injury and/or property damage.

SPICE Model Parameters

This is a secure document. Please copy this code from the SPICE model PDF file on our website (http://www.genesicsemi.com/images/products_sic/rectifiers/GB05SLT12-220_SPICE.pdf) into LTSPICE (version 4) software for simulation of the GB05SLT12-220.

```
*      MODEL OF GeneSiC Semiconductor Inc.
*
*      $Revision:   1.0           $
*      $Date:      04-SEP-2013   $
*
*      GeneSiC Semiconductor Inc.
*      43670 Trade Center Place Ste. 155
*      Dulles, VA 20166
*
*      COPYRIGHT (C) 2013 GeneSiC Semiconductor Inc.
*      ALL RIGHTS RESERVED
*
*      These models are provided "AS IS, WHERE IS, AND WITH NO WARRANTY
*      OF ANY KIND EITHER EXPRESSED OR IMPLIED, INCLUDING BUT NOT LIMITED
*      TO ANY IMPLIED WARRANTIES OF MERCHANTABILITY AND FITNESS FOR A
*      PARTICULAR PURPOSE."
*      Models accurate up to 2 times rated drain current.
*
*      Start of GB05SLT12-220 SPICE Model
*
.SUBCKT GB05SLT12 ANODE KATHODE
R1 ANODE INT R=((TEMP-24)*0.0015); Temperature Dependant Resistor
D1 INT KATHODE GB05SLT12_25C; Call the 25C Diode Model
D2 ANODE KATHODE GB05SLT12_PIN; Call the PiN Diode Model
.MODEL GB05SLT12_25C D
+ IS      5.83E-18      RS      0.1276
+ N       1            IKF     602
+ EG     1.2           XTI     3
+ CJO    3.00E-10     VJ      0.419
+ M      1.6           FC      0.5
+ TT     1.00E-10     BV      1200
+ IBV    1.00E-03     VPK     1200
+ IAVE   5            TYPE    SiC_Schottky
+ MFG    GeneSiC_Semiconductor
.MODEL GB05SLT12_PIN D
+ IS      3.50 E-12     RS      0.3648
+ N       4.409        IKF     73
+ EG     3.23          XTI     -6
+ FC     0.5           TT      0
+ BV     1200          IBV     1.00E-03
+ VPK    1200          IAVE    1
+ TYPE   SiC_PiN
.ENDS
*
*      End of GB05SLT12-220 SPICE Model
```