

DO NOT SCALE FROM THIS PRINT

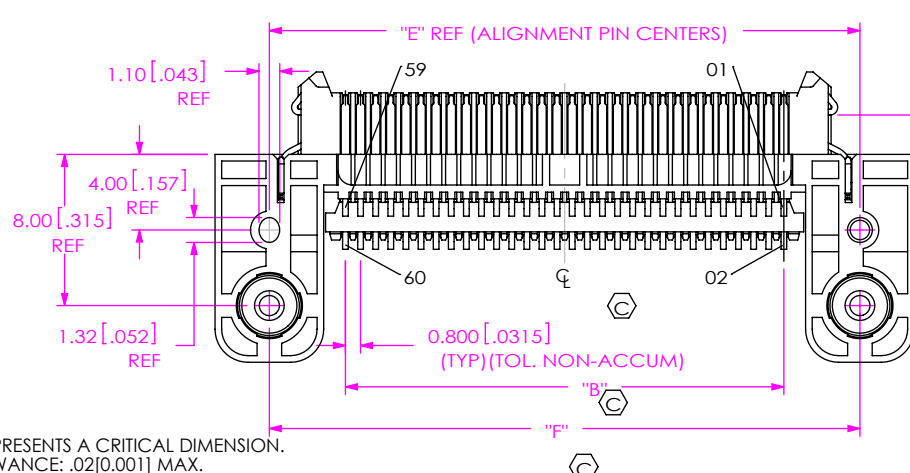
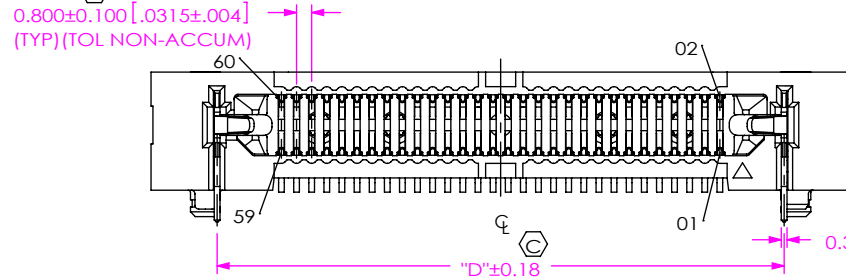
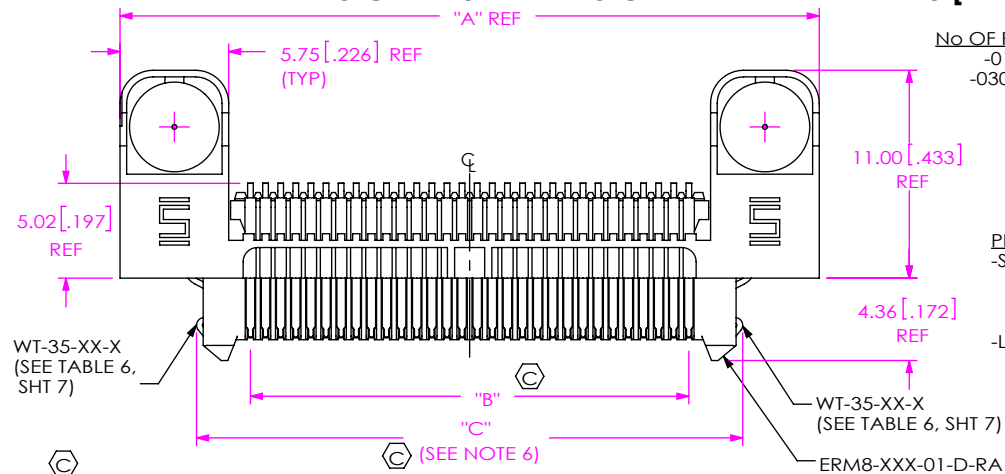

No OF POSITIONS (PER ROW)
 -010, -011, -013, -020, -025
 -030, -037, -040, -049, -050
 -060, -070, -075

LEAD STYLE
 -01: 1.58 [0.062] BOARD
 -03: 2.36 [0.093] BOARD

PLATING SPECIFICATION
 -S: 30µ" SELECTIVE GOLD IN CONTACT AREA, MATTE TIN ON TAIL (USE T-1MXX-01-S, T-1MXX-02-S) (SEE TABLE 6, SHT 7)
 -L: 10µ" SELECTIVE GOLD IN CONTACT AREA, MATTE TIN ON TAIL (USE T-1MXX-01-L, T-1MXX-02-L) (SEE TABLE 6, SHT 7)

TAPE & REEL OPTION
 -TR : TAPE & REEL (STANDARD PACKAGING) (SEE NOTE 4)
 OPTION
 -K: PAD
 -L: ESD LATCHES
 -DS: DIFFERENTIAL PAIR (HOT SWAP)(SEE FIG 2 SHT 7) AVAILABLE ONLY WITH -013, -025, -037 & -049 POSITIONS

-RA: RIGHT ANGLE
 ROW SPECIFICATION
 -D: DOUBLE (USE ERM8-XXX-01-D-RA)

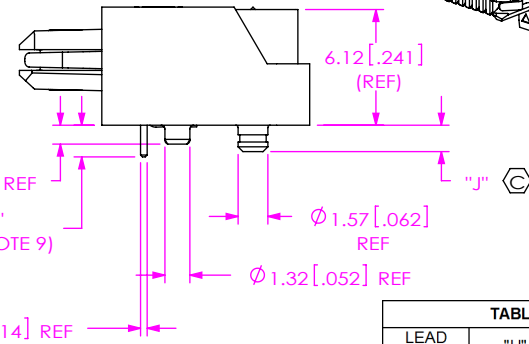
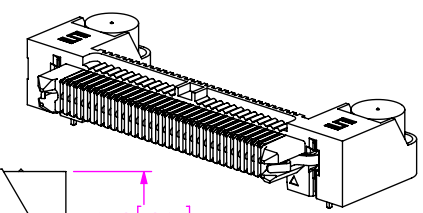

FIG 1 ERM8-030-01-S-D-RA-L

LEAD STYLE	"H"	"J"
-01	1.68 [.066]	1.40 [.055]
-03	2.46 [.097]	2.19 [.086]

POSITION	"A"	"B"	"C"	"D"		"E"	"F"	"K"	"L"
				"-L"	"NON-LATCHING"				
-010	21.00 [.827]	7.20 [.283]	12.90 [.508]	14.00 [.551]	14.05 [.553]	15.25 [.600]	15.25 [.600]	8.00 [.315]	8.00 [.315]
-011	21.80 [.858]	8.00 [.315]	13.70 [.539]	14.80 [.583]	14.85 [.585]	16.05 [.632]	16.05 [.632]	8.80 [.3460]	8.80 [.3460]
-013	23.40 [.921]	9.60 [.378]	15.30 [.602]	16.40 [.646]	16.45 [.648]	17.65 [.695]	17.65 [.695]	10.40 [.409]	10.40 [.409]
-020	29.00 [1.142]	15.20 [.598]	20.90 [.823]	22.00 [.866]	22.05 [.868]	23.25 [.915]	23.25 [.915]	16.00 [.63]	16.00 [.63]
-025	33.00 [1.299]	19.20 [.756]	24.90 [.980]	26.00 [1.024]	26.05 [1.026]	27.25 [1.073]	27.25 [1.073]	20.00 [.787]	20.00 [.787]
-030	37.00 [1.457]	23.20 [.913]	28.90 [1.138]	30.00 [1.181]	30.05 [1.183]	31.25 [1.230]	31.25 [1.230]	24.00 [.945]	24.00 [.945]
-037	42.60 [1.677]	28.80 [1.134]	34.50 [1.358]	35.60 [1.402]	35.65 [1.404]	36.85 [1.451]	36.85 [1.451]	29.60 [1.165]	29.60 [1.165]
-040	45.00 [1.772]	31.20 [1.228]	36.90 [1.453]	38.00 [1.496]	38.05 [1.498]	39.25 [1.545]	39.25 [1.545]	32.00 [1.26]	32.00 [1.26]
-049	52.20 [2.055]	38.40 [1.512]	44.10 [1.736]	45.20 [1.780]	45.25 [1.781]	46.45 [1.829]	46.45 [1.829]	39.20 [1.543]	39.20 [1.543]
-050	53.00 [2.087]	39.20 [1.543]	44.90 [1.768]	46.00 [1.811]	46.05 [1.813]	47.25 [1.860]	47.25 [1.860]	40.00 [1.575]	40.00 [1.575]
-060	61.00 [2.402]	47.20 [1.858]	52.90 [2.083]	54.00 [2.126]	54.05 [2.128]	55.25 [2.175]	55.25 [2.175]	48.00 [1.89]	48.00 [1.89]
-070	69.00 [2.717]	55.20 [2.173]	60.90 [2.398]	62.00 [2.441]	62.05 [2.443]	63.25 [2.490]	63.25 [2.490]	56.00 [2.205]	56.00 [2.205]
-075	73.00 [2.874]	59.20 [2.331]	64.90 [2.555]	66.00 [2.598]	66.05 [2.600]	67.25 [2.648]	67.25 [2.648]	60.00 [2.362]	60.00 [2.362]

- NOTES:
1. C REPRESENTS A CRITICAL DIMENSION.
 2. BURR ALLOWANCE: .02[0.001] MAX.
 3. MINIMUM PUSHOUT /PULLOUT FORCE: SIGNAL: 2.22 N [.5 LB], LATCH AND COUNTERWEIGHT: 4.45 N [1 LB].
 4. FOR QUANTITIES UP TO 49 PIECES, NO LEADER, TRAILER, OR EIA-481-D REEL TO BE SUPPLIED. FOR QUANTITIES FROM 50-124 PIECES, NO LEADER OR TRAILER WILL BE SUPPLIED.
 5. MEASURE AT BEND TANGENCY.
 6. APPLIES TO -L OPTION ONLY.
 7. MAXIMUM CUT BURR ON CUT TAILS IS 0.10[.004].
 8. DIMENSIONS MUST BE MEASURED BOTH ENDS OF COMB OR CONNECTOR.
 9. USE -Z- DATUM ZONE FOR MEASUREMENT ONLY.
 10. SEE PTL SYSTEM FOR REQUIRED INSPECTION FIXTURE TO CHECK TAIL CRITICALS.
 11. WHEN USING AUTOMATED FORMER, COMBS DO NOT NEED TO BE MEASURED AT BOTH ENDS PER NOTE 10. ALL CRITICAL FORM DIMENSIONS CAN BE CHECKED BY VERTEX. FORM 1 CRITICAL DIMENSIONS ARE TO BE CHECKED AT FORM 2 PROCESS STEPS.
 12. USE -E- DATUM ZONE FOR MEASUREMENT ONLY.
 13. USE -D- DATUM ZONE FOR MEASUREMENT ONLY.
 14. COPLANARITY MEASURED ON PINS ONLY, INSULATOR NOT INCLUDED IN MEASUREMENT.

UNLESS OTHERWISE SPECIFIED, DIMENSIONS ARE IN MILLIMETERS [INCHES]. TOLERANCES ARE: DECIMALS ANGLES 2°
 X.X: ±0.3 [.01]
 X.XX: ±0.13 [.005]
 X.XXX: ±0.050 [.0020]

PROPRIETARY NOTE
 THIS DOCUMENT CONTAINS CONFIDENTIAL AND PROPRIETARY INFORMATION AND ALL DESIGN, MANUFACTURING, REPRODUCTION, USE, PATENT RIGHTS AND SALES RIGHTS ARE EXPRESSLY RESERVED BY SAMTEC, INC. THIS DOCUMENT SHALL NOT BE DISCLOSED, IN WHOLE OR PART, TO ANY UNAUTHORIZED PERSON OR ENTITY NOR REPRODUCED, TRANSFERRED OR INCORPORATED IN ANY OTHER PROJECT IN ANY MANNER WITHOUT THE EXPRESS WRITTEN CONSENT OF SAMTEC, INC.



520 PARK EAST BLVD, NEW ALBANY, IN 47150
 PHONE: 812-944-6733 FAX: 812-948-5047
 e-Mail info@SAMTEC.com code 53322

MATERIAL: DO NOT SCALE DRAWING SHEET SCALE: 2:1
 INSULATOR: LCP UL94V-0, COLOR BLACK
 CONTACTS: PHOS BRONZE
 COUNTERWEIGHT: BRASS
 LATCH: BeCu

DESCRIPTION:
 .80mm DUAL ROW RIGHT ANGLE SOCKET ASSEMBLY
 DWG. NO.
 ERM8-XXX-XX-X-D-RA-XX-TR

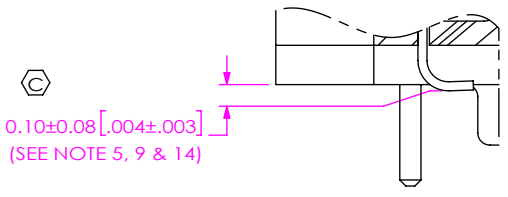
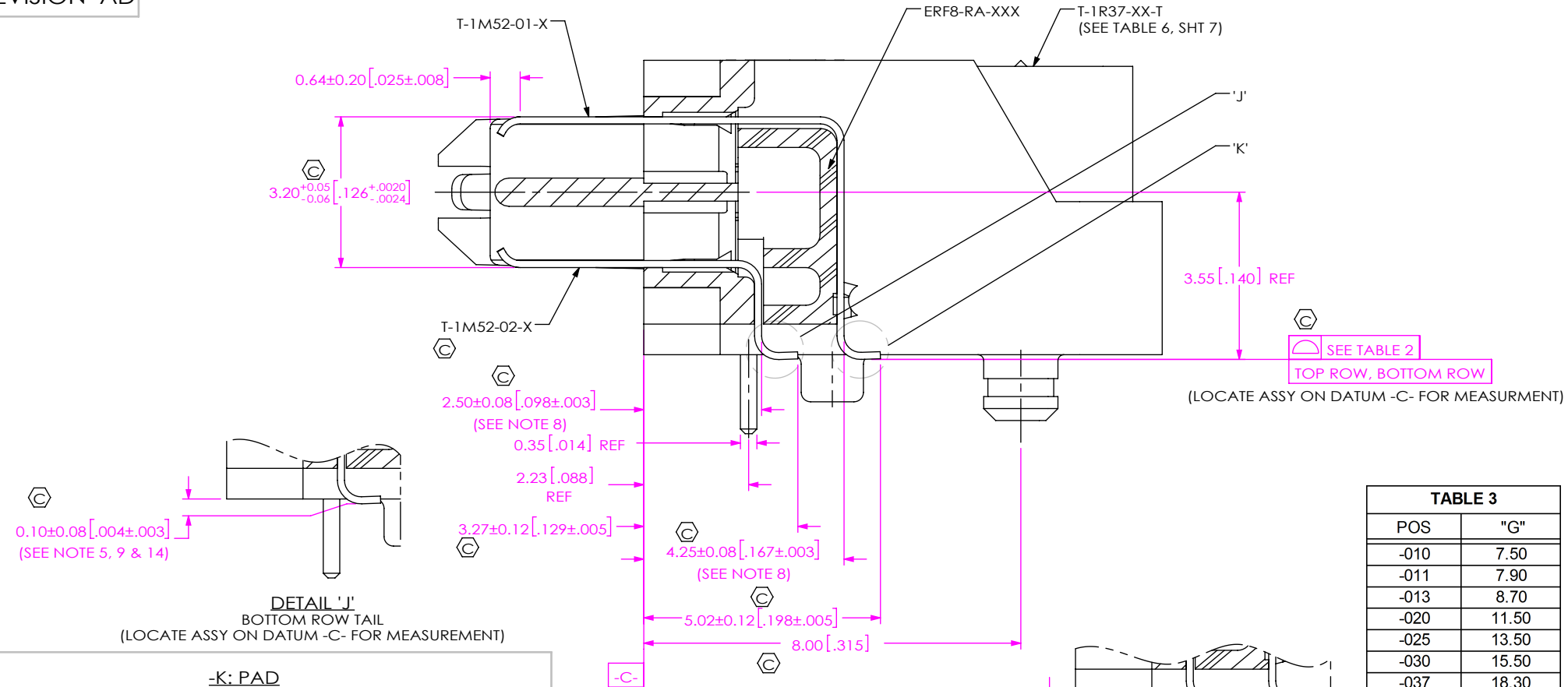

DETAIL 'J'
BOTTOM ROW TAIL
(LOCATE ASSY ON DATUM -C- FOR MEASUREMENT)

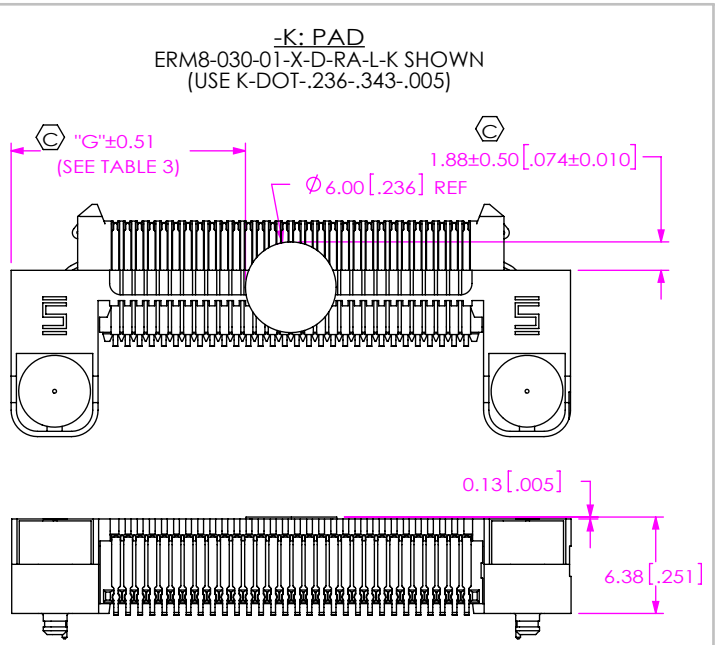

-K: PAD
ERM8-030-01-X-D-RA-L-K SHOWN
(USE K-DOT-.236-.343-.005)

SEE TABLE 2
TOP ROW, BOTTOM ROW

(LOCATE ASSY ON DATUM -C- FOR MEASUREMENT)

POS	"G"
-010	7.50
-011	7.90
-013	8.70
-020	11.50
-025	13.50
-030	15.50
-037	18.30
-040	19.50
-049	23.10
-050	23.50
-060	27.50
-070	31.50
-075	33.50

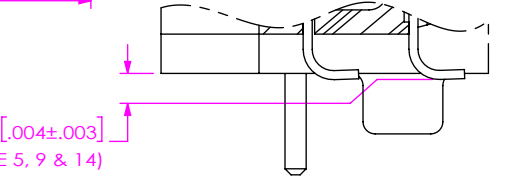

DETAIL 'K'
TOP ROW TAIL
(LOCATE ASSY ON DATUM -C- FOR MEASUREMENT)

No OF POSITIONS	BOTTOM ROW STRAIGHTNESS	TOP ROW STRAIGHTNESS	COPLANARITY
-010 THRU -050	0.08 [.003]	0.08 [.003]	0.10 [.004]
-060 THRU -075	0.10 [.004]	0.10 [.004]	0.15 [.006]

PROPRIETARY NOTE
THIS DOCUMENT CONTAINS CONFIDENTIAL AND PROPRIETARY INFORMATION AND ALL DESIGN, MANUFACTURING, REPRODUCTION, USE, PATENT RIGHTS AND SALES RIGHTS ARE EXPRESSLY RESERVED BY SAMTEC, INC. THIS DOCUMENT SHALL NOT BE DISCLOSED, IN WHOLE OR PART, TO ANY UNAUTHORIZED PERSON OR ENTITY NOR REPRODUCED, TRANSFERRED OR INCORPORATED IN ANY OTHER PROJECT IN ANY MANNER WITHOUT THE EXPRESS WRITTEN CONSENT OF SAMTEC, INC.

DO NOT SCALE DRAWING
SHEET SCALE: 8:1



520 PARK EAST BLVD, NEW ALBANY, IN 47150
PHONE: 812-944-6733 FAX: 812-948-5047
e-Mail info@SAMTEC.com code 55322

DESCRIPTION:
.80mm DUAL ROW RIGHT ANGLE SOCKET ASSEMBLY
DWG. NO.
ERM8-XXX-XX-X-D-RA-XX-TR
BY: C. PIERCE 8/17/2007 SHEET 2 OF 7

REVISION AD

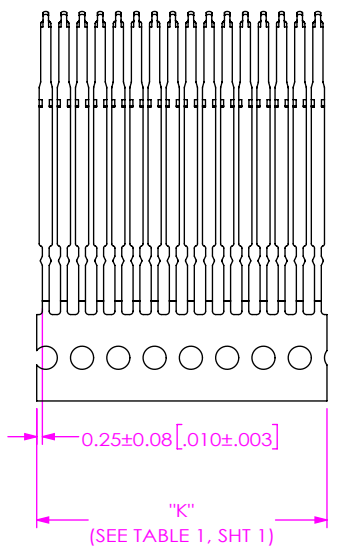

T-1M52-XX-X
IN-PROCESS VIEW

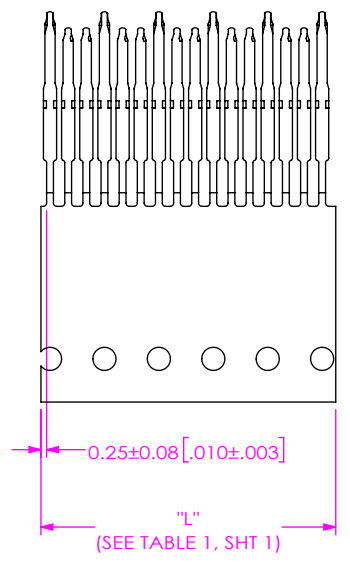

T-1M69-XX-X
IN-PROCESS VIEW

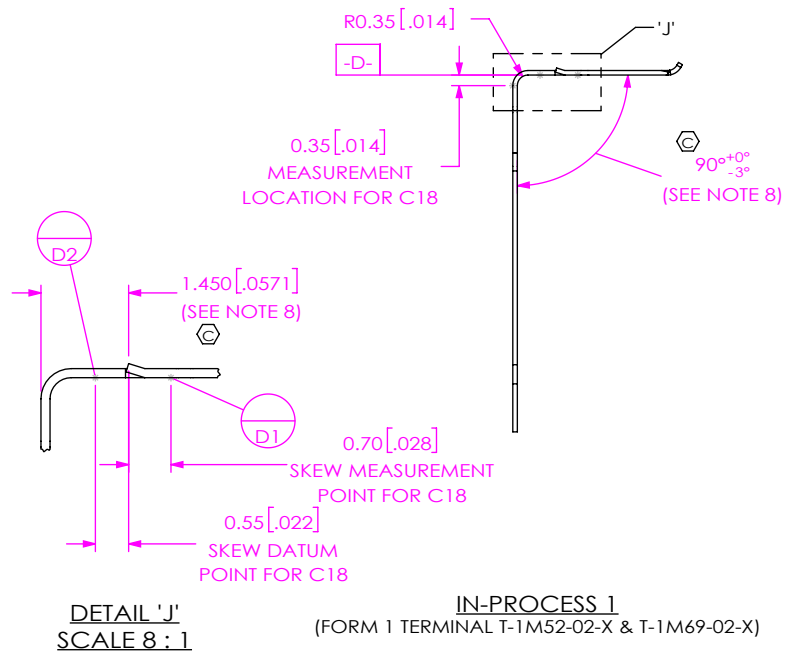

DETAIL 'J'
SCALE 8:1

IN-PROCESS 1
(FORM 1 TERMINAL T-1M52-02-X & T-1M69-02-X)

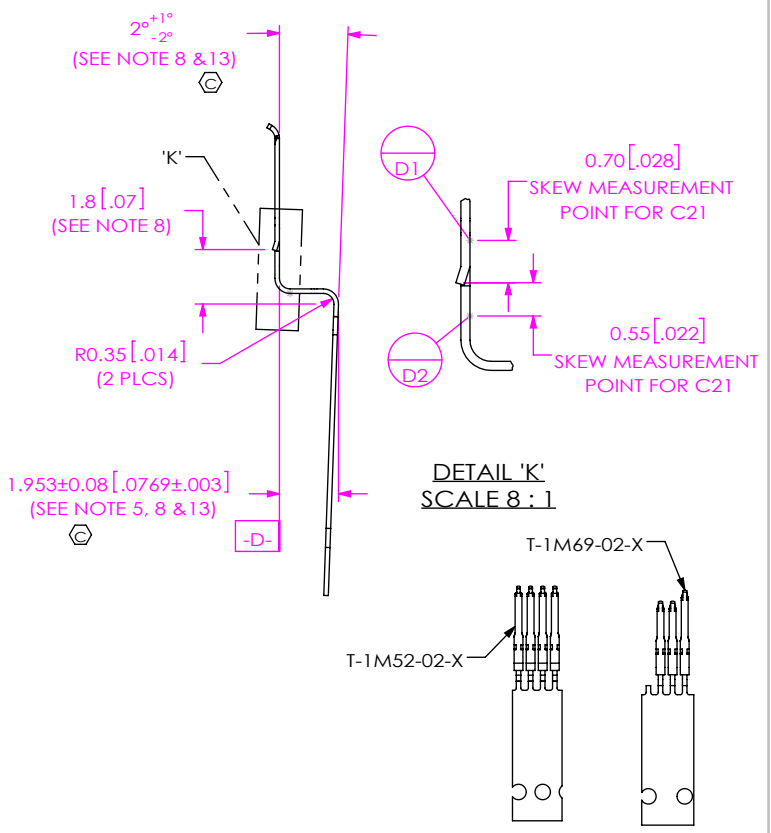

DETAIL 'K'
SCALE 8:1

IN-PROCESS 2
(FORM 2 TERMINAL T-1M52-02-X & T-1M69-02-X)

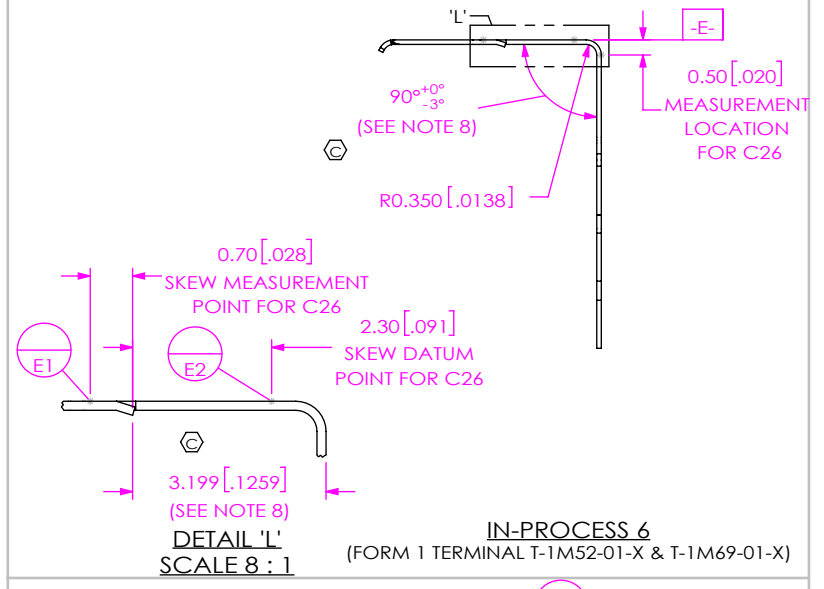

DETAIL 'L'
SCALE 8:1

IN-PROCESS 6
(FORM 1 TERMINAL T-1M52-01-X & T-1M69-01-X)

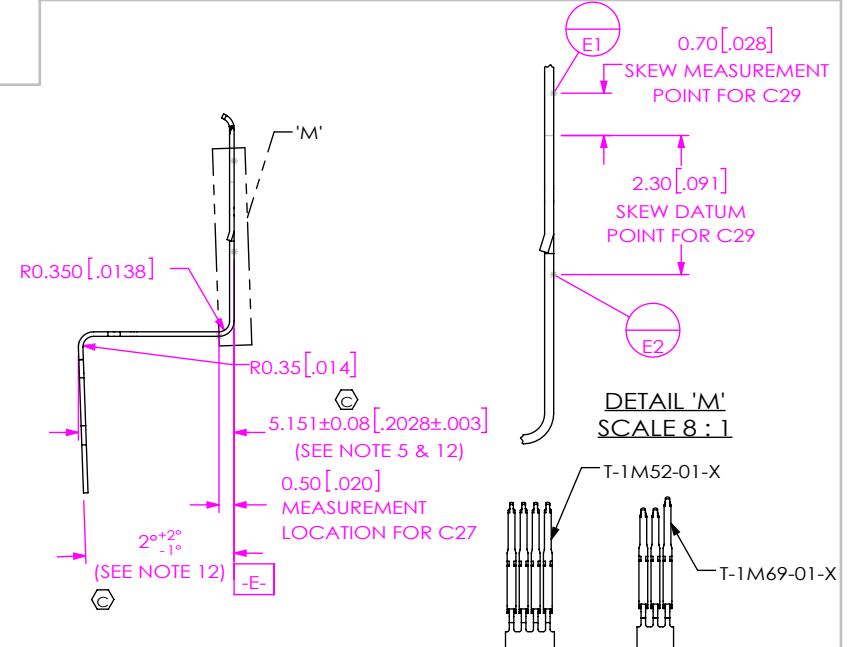

DETAIL 'M'
SCALE 8:1

IN-PROCESS 7
(FORM 2 TERMINAL T-1M52-01-X & T-1M69-01-X)

PROPRIETARY NOTE
THIS DOCUMENT CONTAINS CONFIDENTIAL AND PROPRIETARY INFORMATION AND ALL DESIGN, MANUFACTURING, REPRODUCTION, USE, PATENT RIGHTS AND SALES RIGHTS ARE EXPRESSLY RESERVED BY SAMTEC, INC. THIS DOCUMENT SHALL NOT BE DISCLOSED, IN WHOLE OR PART, TO ANY UNAUTHORIZED PERSON OR ENTITY NOR REPRODUCED, TRANSFERRED OR INCORPORATED IN ANY OTHER PROJECT IN ANY MANNER WITHOUT THE EXPRESS WRITTEN CONSENT OF SAMTEC, INC.

DO NOT SCALE DRAWING
SHEET SCALE: 4:1

520 PARK EAST BLVD, NEW ALBANY, IN 47150
PHONE: 812-944-6733 FAX: 812-948-5047
e-Mail: info@SAMTEC.com code 55322

DESCRIPTION:
.80mm DUAL ROW RIGHT ANGLE SOCKET ASSEMBLY
DWG. NO.
ERM8-XXX-XX-X-D-RA-XX-TR
BY: C. PIERCE 8/17/2007 SHEET 3 OF 7

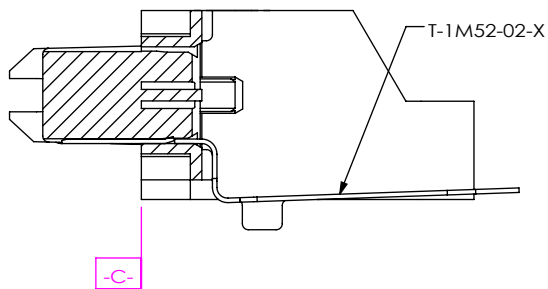

IN-PROCESS 3
(FILL BOTTOM ROW)
(SEE INSPECTION VIEW 1 FOR ASSEMBLY ORIENTATION AND CPC'S)

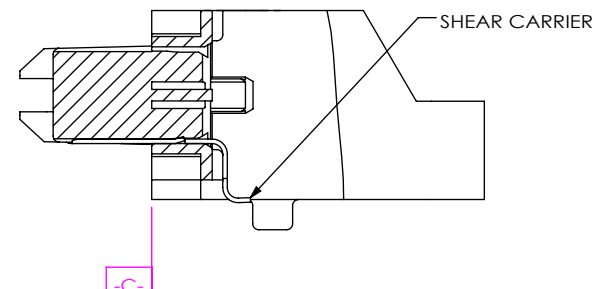

IN-PROCESS 4
(CUT OFF CARRIER)
(SEE INSPECTION VIEW 1 FOR ASSEMBLY ORIENTATION AND CPC'S)

INSPECTION VIEW 1
(SEE NOTE 10)

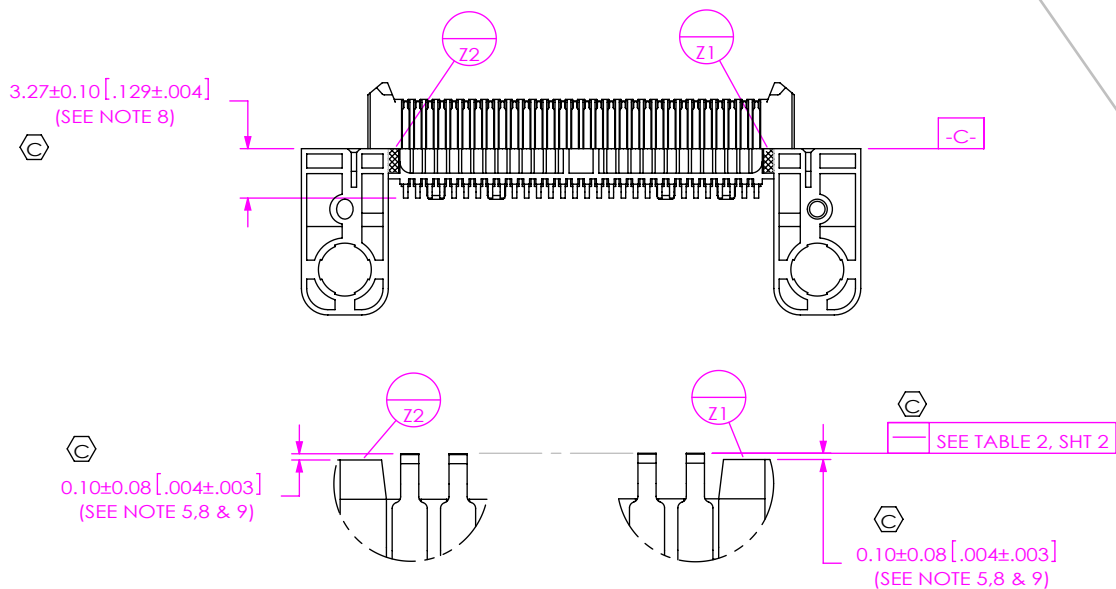

DETAIL 'C'
SCALE 8:1

DETAIL 'D'
SCALE 8:1

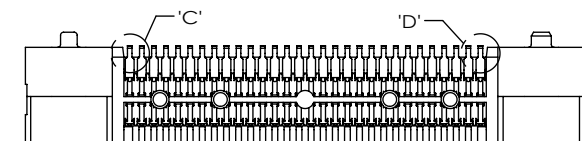

INSPECTION FOR IN-PROCESS 3 & 4
(CARRIER NOT SHOWN FOR IN PROCESS 3 INSPECTIONS)

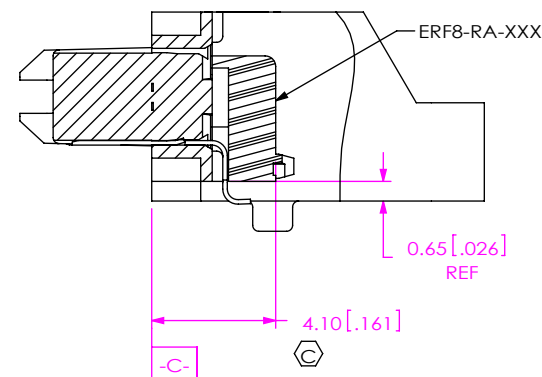

IN-PROCESS 5
FILL ERF8-RA-XXX

c:\enterprisevault\DWG\MISC\MKTG\ERM8-XXX-XX-X-D-RA-XX-TR-MKT.SLDDRW

PROPRIETARY NOTE
THIS DOCUMENT CONTAINS CONFIDENTIAL AND PROPRIETARY INFORMATION AND ALL DESIGN, MANUFACTURING, REPRODUCTION, USE, PATENT RIGHTS AND SALES RIGHTS ARE EXPRESSLY RESERVED BY SAMTEC, INC. THIS DOCUMENT SHALL NOT BE DISCLOSED, IN WHOLE OR PART, TO ANY UNAUTHORIZED PERSON OR ENTITY NOR REPRODUCED, TRANSFERRED OR INCORPORATED IN ANY OTHER PROJECT IN ANY MANNER WITHOUT THE EXPRESS WRITTEN CONSENT OF SAMTEC, INC.

DO NOT SCALE DRAWING

SHEET SCALE: 4:1



520 PARK EAST BLVD, NEW ALBANY, IN 47150
PHONE: 812-944-6733 FAX: 812-948-5047
e-Mail info@SAMTEC.com code 55322

DESCRIPTION:
.80mm DUAL ROW RIGHT ANGLE SOCKET ASSEMBLY

DWG. NO.
ERM8-XXX-XX-X-D-RA-XX-TR

BY: C. PIERCE 8/17/2007 SHEET 4 OF 7

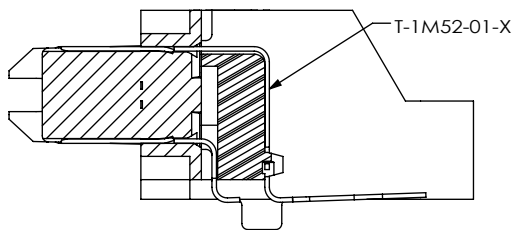

IN-PROCESS 8
(FILL TOP ROW)
(SEE INSPECTION VIEW 2 FOR ASSEMBLY ORIENTATION AND CPC'S)

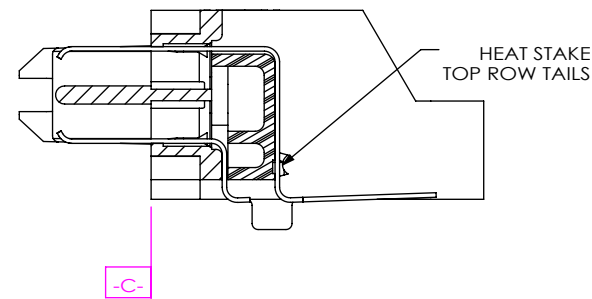

IN-PROCESS 9
(HEAT STAKE TOP ROW OF CONTACTS)
(SEE INSPECTION VIEW 2 FOR ASSEMBLY ORIENTATION AND CPC'S)

INSPECTION VIEW 2
(SEE NOTE 10)

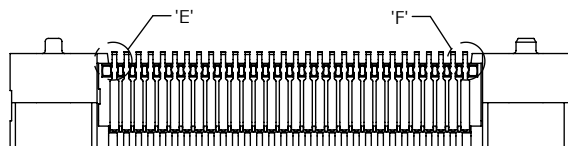
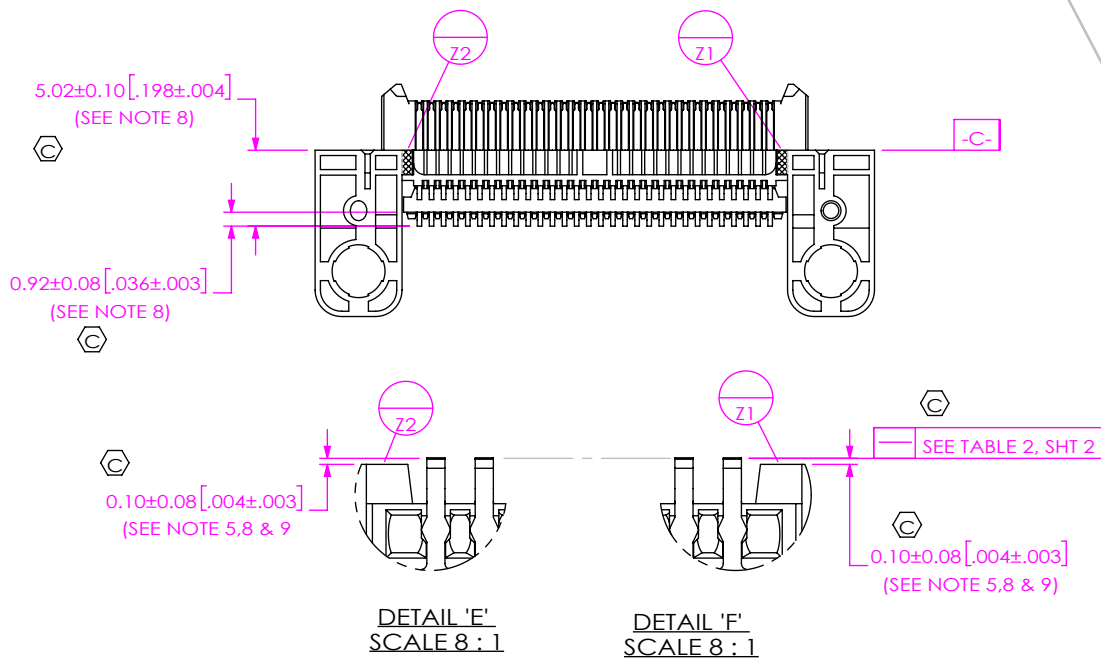

INSPECTION FOR IN-PROCESS 8, 9 & 10
(CARRIER NOT SHOWN FOR IN PROCESS 8 INSPECTIONS)

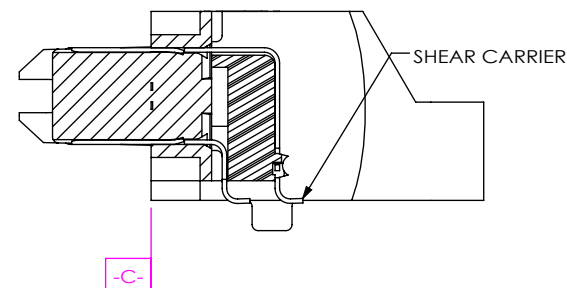

IN-PROCESS 10
(CUT OFF CARRIER)
(SEE INSPECTION VIEW 2 FOR ASSEMBLY ORIENTATION AND CPC'S)

c:\enterprise\vault\DWG\MISC\MKTG\ERM8-XXX-XX-X-D-RA-XX-TR-MKT.SLDDRW

PROPRIETARY NOTE
THIS DOCUMENT CONTAINS CONFIDENTIAL AND PROPRIETARY INFORMATION AND ALL DESIGN, MANUFACTURING, REPRODUCTION, USE, PATENT RIGHTS AND SALES RIGHTS ARE EXPRESSLY RESERVED BY SAMTEC, INC. THIS DOCUMENT SHALL NOT BE DISCLOSED, IN WHOLE OR PART, TO ANY UNAUTHORIZED PERSON OR ENTITY NOR REPRODUCED, TRANSFERRED OR INCORPORATED IN ANY OTHER PROJECT IN ANY MANNER WITHOUT THE EXPRESS WRITTEN CONSENT OF SAMTEC, INC.



520 PARK EAST BLVD, NEW ALBANY, IN 47150
PHONE: 812-944-6733 FAX: 812-948-5047
e-Mail info@SAMTEC.com code 55322

DO NOT SCALE DRAWING

SHEET SCALE: 2:1

DESCRIPTION:
.80mm DUAL ROW RIGHT ANGLE SOCKET ASSEMBLY

DWG. NO.
ERM8-XXX-XX-X-D-RA-XX-TR

BY: C. PIERCE 8/17/2007 SHEET 5 OF 7

REVISION AD

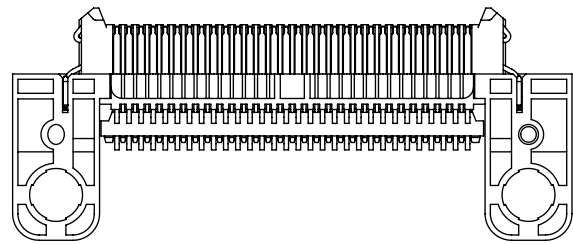
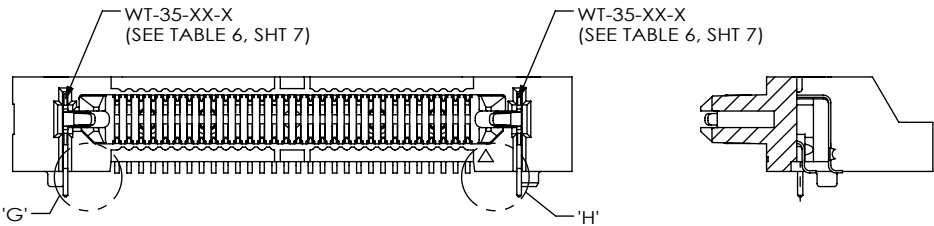

IN-PROCESS 11
FILL WT-35-XX-F
(ERM8-030-01-S-D-RA-L SHOWN)

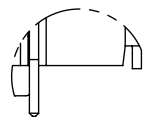

DETAIL 'G'
SCALE 4 : 1

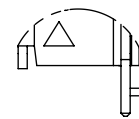

DETAIL 'H'
SCALE 4 : 1

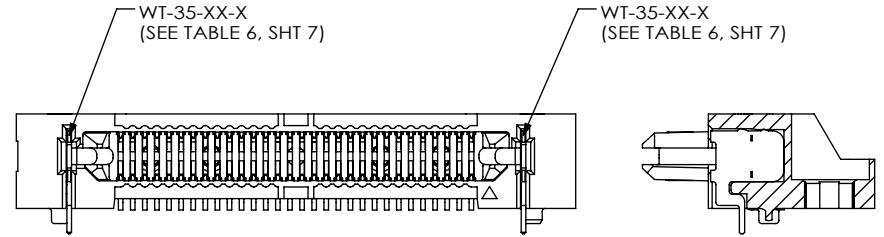

IN-PROCESS 11
FILL WT-35-XX-F
(ERM8-030-01-S-D-RA SHOWN)

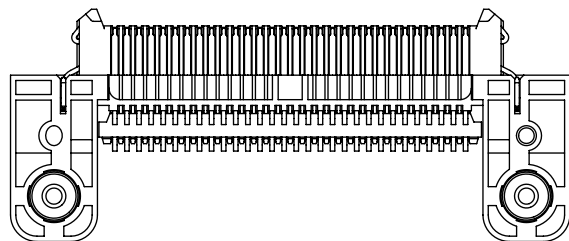

IN-PROCESS 12
FILL T-1R37-XX-T
(SEE TABLE 6, SHT 7)

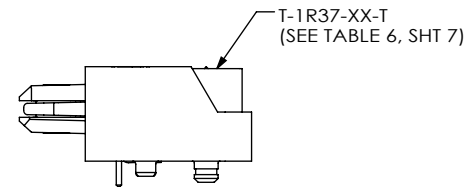

c:\enterprisevault\DWG\MISC\MKTG\ERM8-XXX-XX-X-D-RA-XX-TR-MKT.SLDDRW

PROPRIETARY NOTE
THIS DOCUMENT CONTAINS CONFIDENTIAL AND PROPRIETARY INFORMATION AND ALL DESIGN, MANUFACTURING, REPRODUCTION, USE, PATENT RIGHTS AND SALES RIGHTS ARE EXPRESSLY RESERVED BY SAMTEC, INC. THIS DOCUMENT SHALL NOT BE DISCLOSED, IN WHOLE OR PART, TO ANY UNAUTHORIZED PERSON OR ENTITY NOR REPRODUCED, TRANSFERRED OR INCORPORATED IN ANY OTHER PROJECT IN ANY MANNER WITHOUT THE EXPRESS WRITTEN CONSENT OF SAMTEC, INC.

DO NOT SCALE DRAWING

SHEET SCALE: 2:1



520 PARK EAST BLVD, NEW ALBANY, IN 47150
PHONE: 812-944-6733 FAX: 812-948-5047
e-Mail info@SAMTEC.com code 55322

DESCRIPTION:
.80mm DUAL ROW RIGHT ANGLE SOCKET ASSEMBLY

DWG. NO.

ERM8-XXX-XX-X-D-RA-XX-TR

BY: C. PIERCE 8/17/2007 SHEET 6 OF 7

TABLE 6

OPTION	STYLE	BODY CALLOUT	SPACER BODY	TERMINALS	COUNTERWEIGHT	WELD TABS
NONE	-01	ERM8-XXX-01-D-RA	ERF8-RA-XX	T-1M52-01-X T-1M52-02-X	T-1R37-01-X	WT-35-03-T
	-03	ERM8-XXX-01-D-RA	ERF8-RA-XX	T-1M52-01-X T-1M52-02-X	T-1R37-02-X	WT-35-06-T
-L	-01	ERM8-XXX-01-D-RA	ERF8-RA-XX	T-1M52-01-X T-1M52-02-X	T-1R37-01-X	WT-35-01-F WT-35-02-F
	-03	ERM8-XXX-01-D-RA	ERF8-RA-XX	T-1M52-01-X T-1M52-02-X	T-1R37-02-X	WT-35-04-F WT-35-05-F
-DS	-01	ERM8-XXX-01-D-RA	ERF8-RA-XX	T-1M69-01-X T-1M69-02-X	T-1R37-01-X	WT-35-03-T
	-03	ERM8-XXX-01-D-RA	ERF8-RA-XX	T-1M69-01-X T-1M69-02-X	T-1R37-02-X	WT-35-06-T
-DS & -L	-01	ERM8-XXX-01-D-RA	ERF8-RA-XX	T-1M69-01-X T-1M69-02-X	T-1R37-01-X	WT-35-01-F WT-35-02-F
	-03	ERM8-XXX-01-D-RA	ERF8-RA-XX	T-1M69-01-X T-1M69-02-X	T-1R37-02-X	WT-35-04-F WT-35-05-F

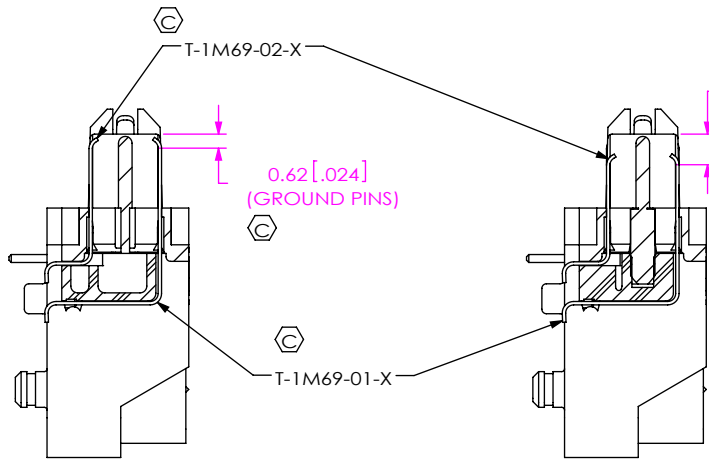

SECTION "A"-"A"
SCALE 3 : 1

SECTION "B"-"B"
SCALE 3 : 1

FIG 2
ERM8-025-01-X-D-RA-DS-L SHOWN
(DIFFERENT AS SHOWN, OTHERWISE SAME AS FIG 1)

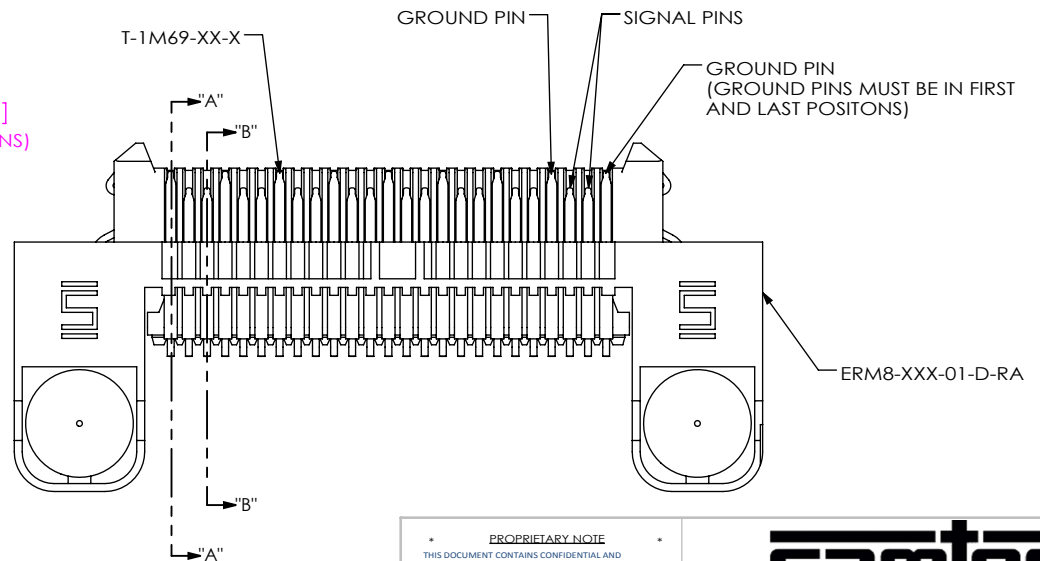

PROPRIETARY NOTE
THIS DOCUMENT CONTAINS CONFIDENTIAL AND PROPRIETARY INFORMATION AND ALL DESIGN, MANUFACTURING, REPRODUCTION, USE, PATENT RIGHTS AND SALES RIGHTS ARE EXPRESSLY RESERVED BY SAMTEC, INC. THIS DOCUMENT SHALL NOT BE DISCLOSED, IN WHOLE OR IN PART, TO ANY UNAUTHORIZED PERSON OR ENTITY NOR REPRODUCED, TRANSFERRED OR INCORPORATED IN ANY OTHER PROJECT IN ANY MANNER WITHOUT THE EXPRESS WRITTEN CONSENT OF SAMTEC, INC.

DO NOT SCALE DRAWING

SHEET SCALE: 2:1



520 PARK EAST BLVD, NEW ALBANY, IN 47150
PHONE: 812-944-6733 FAX: 812-948-5047
e-Mail info@SAMTEC.com code 55322

DESCRIPTION:
.80mm DUAL ROW RIGHT ANGLE SOCKET ASSEMBLY

DWG. NO.
ERM8-XXX-XX-X-D-RA-XX-TR

BY: C. PIERCE 8/17/2007 SHEET 7 OF 7