

DO NOT SCALE FROM THIS PRINT

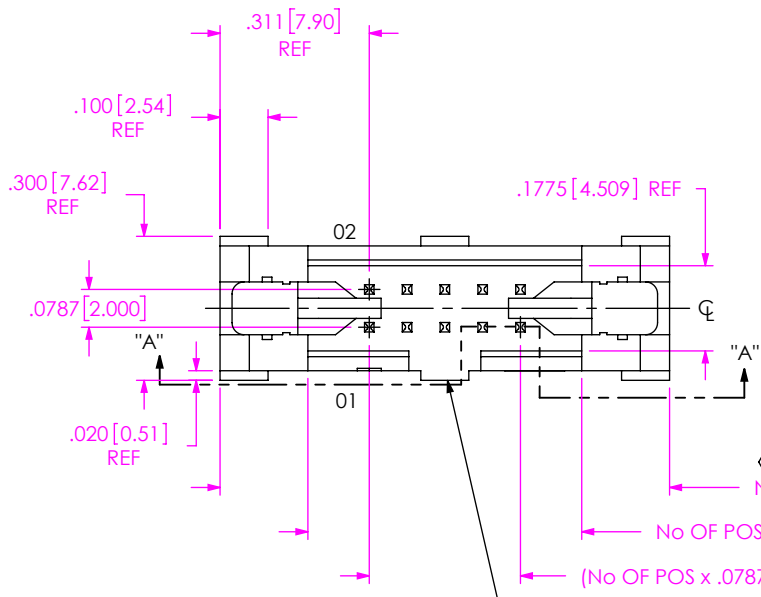

No OF POSITIONS  
-05 THRU -25

LEAD STYLE  
-01

PLATING SPECIFICATION

OPTION 3  
-TR: TAPE AND REEL PACKAGING (FOR -SM, -SM-P, AND -SM-K ONLY)

OPTION 2  
-LC: LOCKING CLIP (SEE NOTE 4) (FOR -SM ONLY) (SEE FIG 4, SHT 2, USE LC-09-TM)

OPTION 1  
-P: PICK & PLACE PAD (SEE FIG 5, SHT 2) (FOR -SM ONLY, USE PPP-24) (USE PPP-55 WITH -SM-TR OPTION)

-K: OPTION (POLYIMIDE FILM, SEE FIG 3, SHT 2) (FOR -SM ONLY)

POLARIZED OPTION  
-XX = PIN OMITTED

TAIL OPTION  
-RA: RIGHT ANGLE (FIG 2, SHT 2)  
-SM: SURFACE MOUNT (SEE FIG 4, SHT 2) (LEAVE BLANK FOR THRU HOLE)

ROW SPECIFICATION  
-D: DOUBLE

PIN	OAL
T-1S13-05-XX-2	0.397 [10.08]
T-1S13-06-XX-2	0.555 [14.10]
T-1S13-15-XX-2	0.714 [18.14]

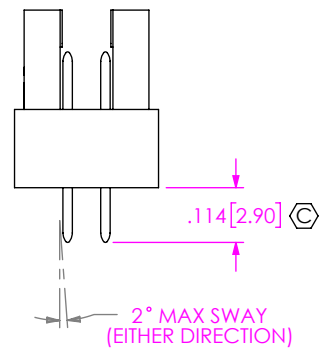
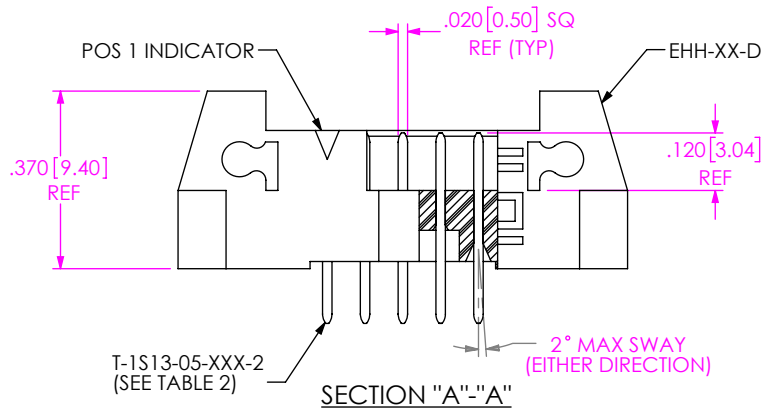

FIG1 (EHT-105-01-XX-D SHOWN) (LATCH EHA-01 REMOVED FOR CLARITY)

NOTES:

1. Ⓢ REPRESENTS A CRITICAL DIMENSION.
2. MINIMUM PUSHOUT FORCE: 1 LB.
3. MAXIMUM PIN ROTATION IN BODY: 2°
4. DUE TO THE HIGH AMOUNT OF INSERTION FORCE NEEDED, THE -LC OPTION IS NOT COMPATIBLE WITH AUTO PLACEMENT. SAMTEC RECOMMENDS MANUAL PLACEMENT FOR ALL ASSEMBLIES WITH THE -LC OPTION.

UNLESS OTHERWISE SPECIFIED, DIMENSIONS ARE IN INCHES. TOLERANCES ARE:

DECIMALS	ANGLES
.XX: ±.01 [0.3]	2°
.XXX: ±.005 [0.13]	
.XXXX: ±.0020 [0.051]	

PROPRIETARY NOTE

THIS DOCUMENT CONTAINS CONFIDENTIAL AND PROPRIETARY INFORMATION AND ALL DESIGN, MANUFACTURING, REPRODUCTION, USE, PATENT RIGHTS AND SALES RIGHTS ARE EXPRESSLY RESERVED BY SAMTEC, INC. THIS DOCUMENT SHALL NOT BE DISCLOSED, IN WHOLE OR PART, TO ANY UNAUTHORIZED PERSON OR ENTITY NOR REPRODUCED, TRANSFERRED OR INCORPORATED IN ANY OTHER PROJECT IN ANY MANNER WITHOUT THE EXPRESS WRITTEN CONSENT OF SAMTEC, INC.



520 PARK EAST BLVD, NEW ALBANY, IN 47150  
PHONE: 812-944-6733 FAX: 812-948-5047  
e-Mail: info@SAMTEC.com code: 55322

MATERIAL: DO NOT SCALE DRAWING SHEET SCALE: 2.5:1  
INSULATOR: LCP, UL 94 VO, COLOR: BLACK  
TERMINAL: PHOS BRONZE

DESCRIPTION:  
2MM EJECTOR HEADER ASSEMBLY

DWG. NO.  
EHT-1XX-01-XX-D-XX-XX-X-XX-XX

BY: PURVIS 02/28/1994 SHEET 1 OF 3

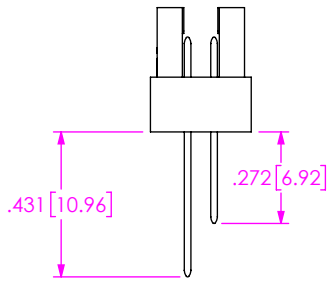

-RA IN PROCESS

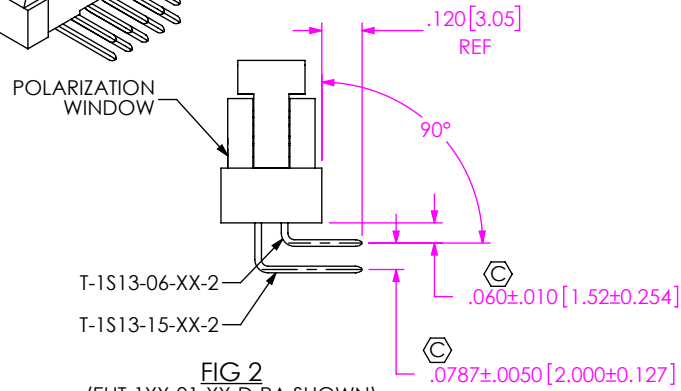
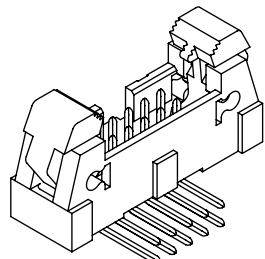
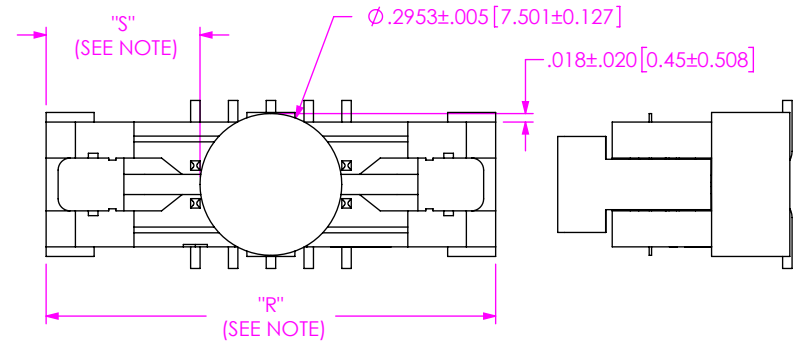

FIG 2  
(EHT-1XX-01-XX-D-RA SHOWN)  
RIGHT ANGLE  
(DIFFERENT AS SHOWN, OTHERWISE SAME AS FIG 1)



NOTE: "R" = USE MEASURED DIMENSION (REF)  
"S" = {"R" - .2953[7.501]/2} ± .020[0.51]

FIG 3  
(EHT-105-01-XX-D-SM-K SHOWN)  
-K OPTION (POLYIMIDE FILM PAD)  
(DIFFERENT AS SHOWN, OTHERWISE SAME AS FIG 1)

NOTE: "R" = USE MEASURED DIMENSION (REF)  
"S" = {"R" - .325[8.26]/2} ± .020[0.51]

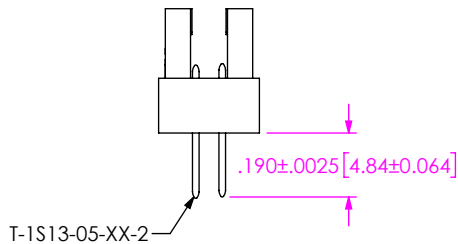

-SM IN-PROCESS 1

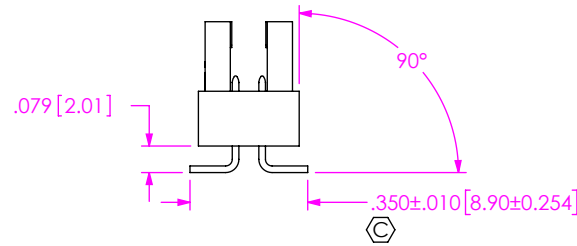

-SM IN-PROCESS 2

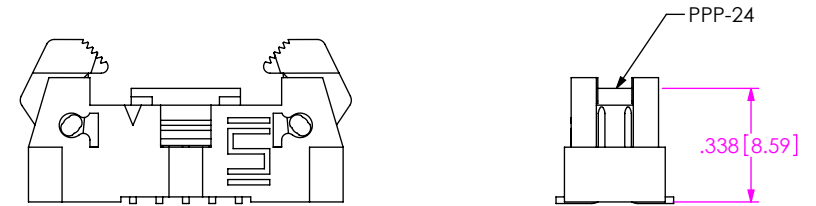
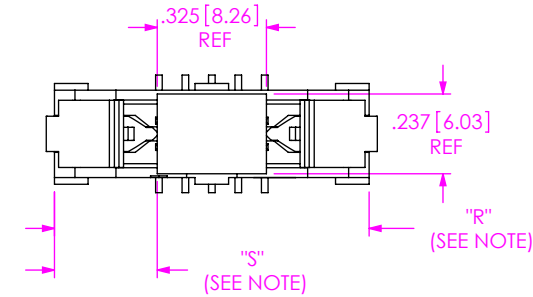

(LATCH EHA-01 REMOVED FOR CLARITY)

FIG 5  
(EHT-105-01-XX-D-SM-P SHOWN)  
PICK AND PLACE PAD  
(DIFFERENT AS SHOWN, OTHERWISE SAME AS FIG 1)

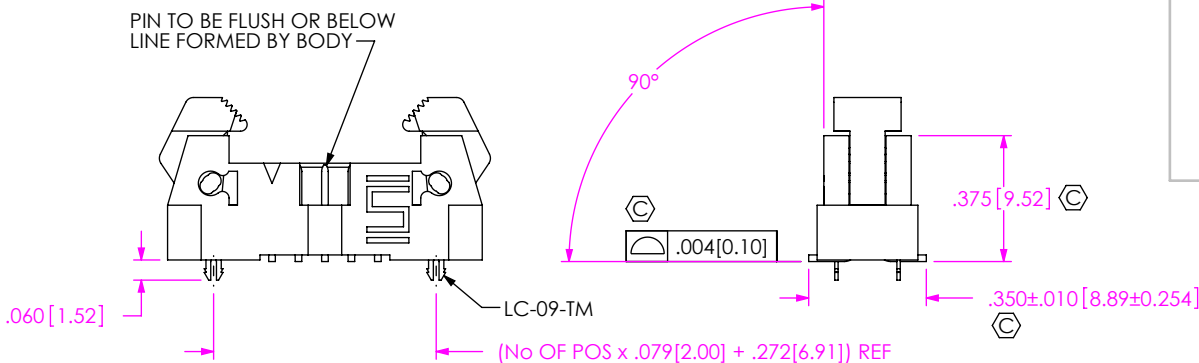

FIG 4  
(EHT-105-01-XX-D-SM-LC SHOWN)  
SURFACE MOUNT VERSION  
(DIFFERENT AS SHOWN, OTHERWISE SAME AS FIG 1)

PROPRIETARY NOTE  
THIS DOCUMENT CONTAINS CONFIDENTIAL AND PROPRIETARY INFORMATION AND ALL DESIGN, MANUFACTURING, REPRODUCTION, USE, PATENT RIGHTS AND SALES RIGHTS ARE EXPRESSLY RESERVED BY SAMTEC, INC. THIS DOCUMENT SHALL NOT BE DISCLOSED, IN WHOLE OR PART, TO ANY UNAUTHORIZED PERSON OR ENTITY NOR REPRODUCED, TRANSFERRED OR INCORPORATED IN ANY OTHER PROJECT IN ANY MANNER WITHOUT THE EXPRESS WRITTEN CONSENT OF SAMTEC, INC.

DO NOT SCALE DRAWING  
SHEET SCALE: 1:0.571429



520 PARK EAST BLVD, NEW ALBANY, IN 47150  
PHONE: 812-944-6733 FAX: 812-948-5047  
e-Mail: info@SAMTEC.com code: 55322

DESCRIPTION:  
2MM EJECTOR HEADER ASSEMBLY

DWG. NO.  
EHT-1XX-01-XX-D-XX-XX-X-XX-XX

BY: PURVIS 02/28/1994 SHEET 2 OF 3

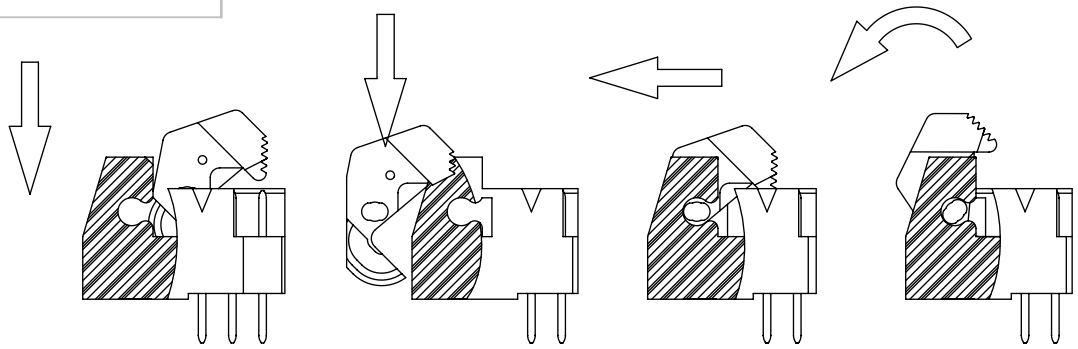

IN-PROCESS  
ARM ASSEMBLY & ROTATION

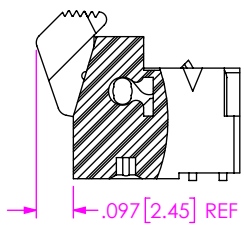

LATCH OPEN VIEW

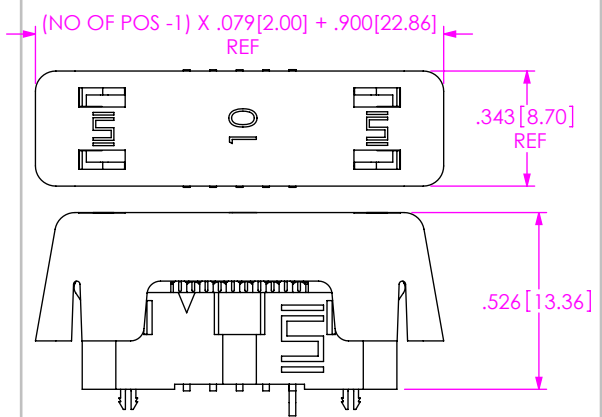
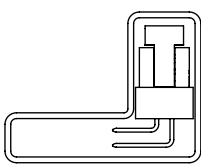
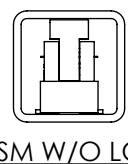
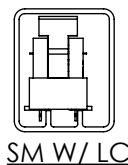
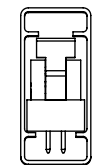
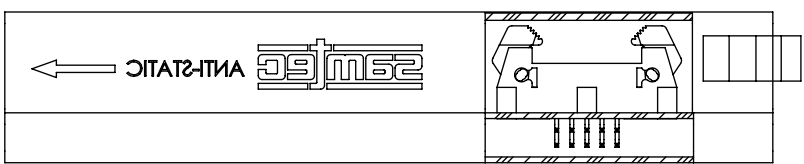
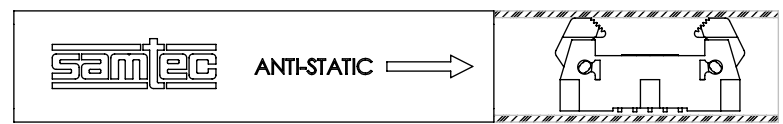
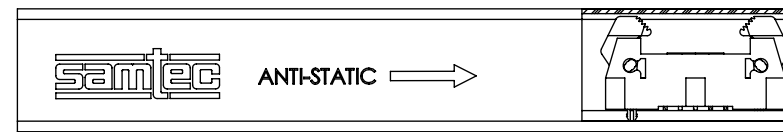
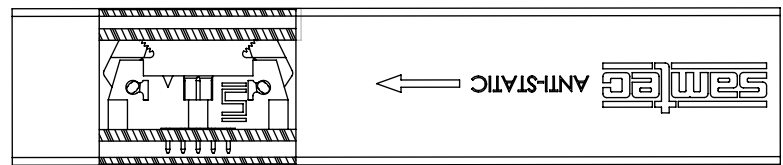
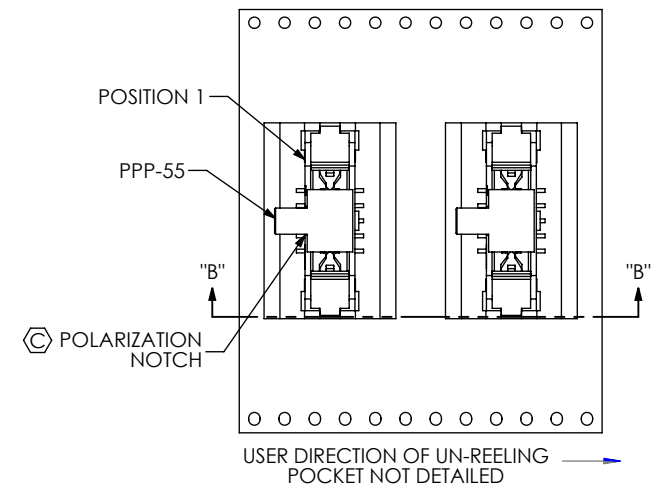

FIG 6  
APPLICATION VIEW  
EHT MATED TO TCSD AND ECF



SM W/LC

SM W/O LC



SECTION "B"- "B"  
SCALE 1 : 1

TABLE 1		
STYLE	TUBE	PLUG
STRAIGHT	PT-1-24-16-29	TP-13
RIGHT ANGLE	ASP-90341-01-S	TP-13
W/ -K, W/O -K SURFACE MOUNT W/ LC	PT-1-24-01-58	TP-13
W/ -K, W/O -K SURFACE MOUNT W/O LC	PT-1-24-01-08	TP-13

FIG 7  
PACKAGING VIEWS

**PROPRIETARY NOTE**  
THIS DOCUMENT CONTAINS CONFIDENTIAL AND PROPRIETARY INFORMATION AND ALL DESIGN, MANUFACTURING, REPRODUCTION, USE, PATENT RIGHTS AND SALES RIGHTS ARE EXPRESSLY RESERVED BY SAMTEC, INC. THIS DOCUMENT SHALL NOT BE DISCLOSED, IN WHOLE OR PART, TO ANY UNAUTHORIZED PERSON OR ENTITY NOR REPRODUCED, TRANSFERRED OR INCORPORATED IN ANY OTHER PROJECT IN ANY MANNER WITHOUT THE EXPRESS WRITTEN CONSENT OF SAMTEC, INC.

DO NOT SCALE DRAWING

SHEET SCALE: 2:1



520 PARK EAST BLVD, NEW ALBANY, IN 47150  
PHONE: 812-944-6733 FAX: 812-948-5047  
e-Mail: info@SAMTEC.com code: 55322

DESCRIPTION:  
2MM EJECTOR HEADER ASSEMBLY

DWG. NO.  
EHT-1XX-01-XX-D-XX-XX-X-XX-XX

BY: PURVIS 02/28/1994 SHEET 3 OF 3