

Features

- RoHS compliant*
- Low capacitance - 0.04 pF (I/O to I/O)
- ESD protection to IEC 61000-4-2 (Level 4)

Applications

- HDMI 1.3, 1.4 and 2.0
- DisplayPort
- Digital Visual Interface (DVI)
- SATA and eSATA
- USB 3.0
- Memory protection
- SIM card ports

CDDFN10-3324P - Surface Mount TVS Diode Array

General Information

The Model CDDFN10-3324P device provides ESD, CDE and EFT protection for high-speed data ports, meeting IEC 61000-4-2 (ESD) requirements. The Transient Voltage Suppressor array, protecting up to four data lines, offers a Working Peak Reverse Voltage of 3.3 V and a Minimum Breakdown Voltage of 4.5 V.

The DFN10 packaged device has an ultra-low typical capacitance of only 0.04 pF between I/O lines. This allows it to be used for protecting sensitive components used on high-speed interfaces. The small footprint of the device allows for flow-through routing on the PCB, helping to maintain matched impedances of the high-speed data lines.

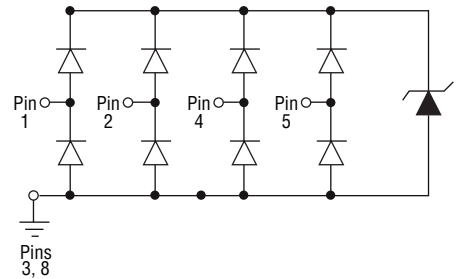

Absolute Maximum Ratings (@ T_A = 25 °C Unless Otherwise Noted)

Parameter	Symbol	CDDFN10-3324P	Unit
Peak Pulse Power (t _p = 8/20 μS)	P _{pp}	30	W
Peak Pulse Current (t _p = 8/20 μS)	I _{pp}	4	A
Operating Temperature	T _J	-55 to +85	°C
Storage Temperature	T _{STG}	-55 to +150	°C

Electrical Characteristics (@ T_A = 25 °C Unless Otherwise Noted)

Parameter	Symbol	Min.	Typ.	Max.	Unit
Working Peak Reverse Voltage	V _{WM}			3.3	V
Breakdown Voltage @ 1 mA	V _{BR}	4.5			V
Leakage Current @ V _{WM}	I _R		0.1	0.5	μA
Capacitance @ 1.65 V, f = 1 MHz (I/O to GND)	C _{IN}		0.45	0.65	pF
Capacitance @ 1.65 V, f = 1 MHz (I/O to I/O)	C _{CROSS}		0.04	0.08	pF
Clamping Voltage @ 8/20 μs @ I _{pp}	V _C			7.5	V
ESD Protection per IEC 6-1000-4-2					
Contact Discharge				12	kV
Air Discharge				15	kV

*RoHS Directive 2002/95/EC Jan. 27, 2003 including annex and RoHS Recast 2011/65/EU June 8, 2011.

Specifications are subject to change without notice.

The device characteristics and parameters in this data sheet can and do vary in different applications and actual device performance may vary over time. Users should verify actual device performance in their specific applications.

CDDFN10-3324P - Surface Mount TVS Diode Array

BOURNS®

Product Dimensions

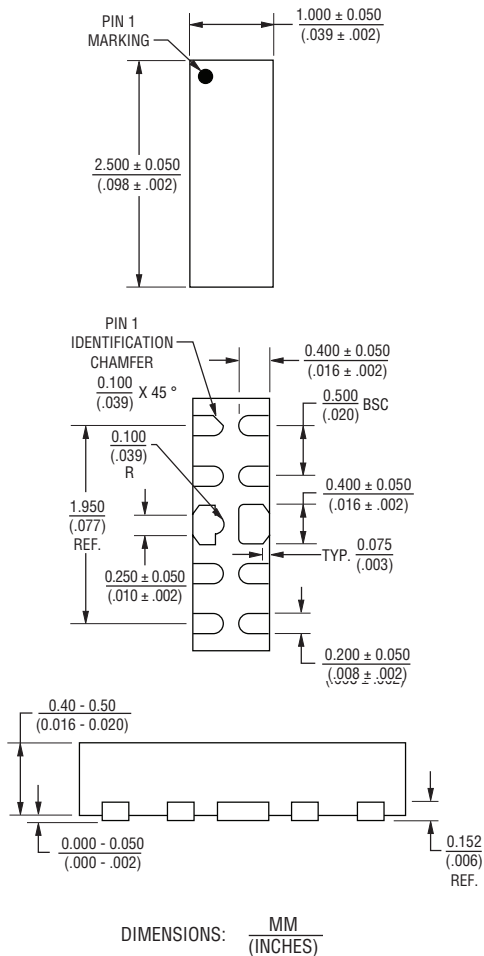

Recommended Footprint

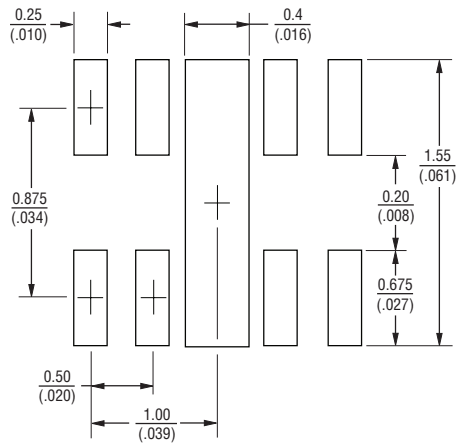

Typical Part Marking

CDDFN10-3324P324

Environmental Specifications

Moisture Sensitivity Level3
 ESD Classification (HBM)3B

How to Order

CD DFN10 - 33 24 P

Common Code _____
 Chip Diode

Package _____
 DFN10 = DFN-10 Package

Working Peak Reverse Voltage _____
 33 = 3.3 V_{RWM} (Volts)

Number of Lines _____
 24 = 2 Ground / 4 Data Lines

Suffix _____
 P = Ultra-low Capacitance

Device Pinout

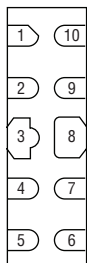

TOP VIEW

Pin	Function
1,2,4,5	Input and Output Lines
6,7,9,10	NC (No Internal Connection) for Feed-Through Layout design
3,8	GND

Specifications are subject to change without notice.

The device characteristics and parameters in this data sheet can and do vary in different applications and actual device performance may vary over time. Users should verify actual device performance in their specific applications.

CDDFN10-3324P - Surface Mount TVS Diode Array

BOURNS®

Rating & Characteristic Curves

Typical Voltage vs. Capacitance C_{IN}

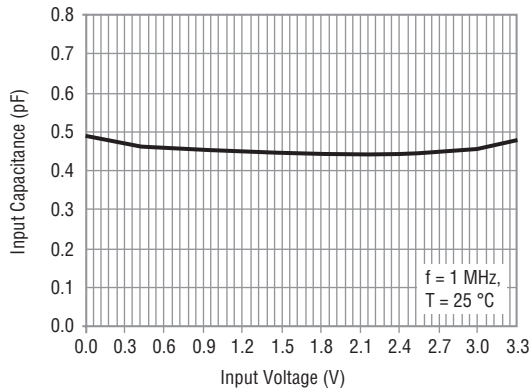

Typical Voltage vs. Capacitance C_{CROSS}

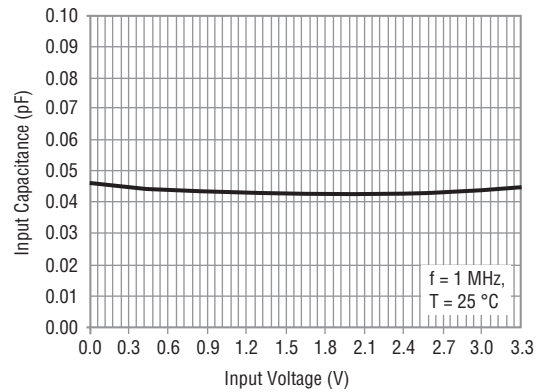

Typical Insertion Loss S21

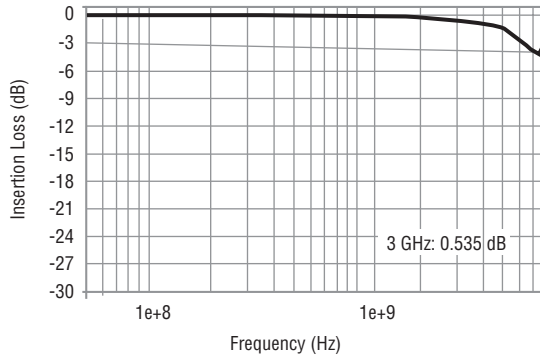

Typical Analog Cross Talk

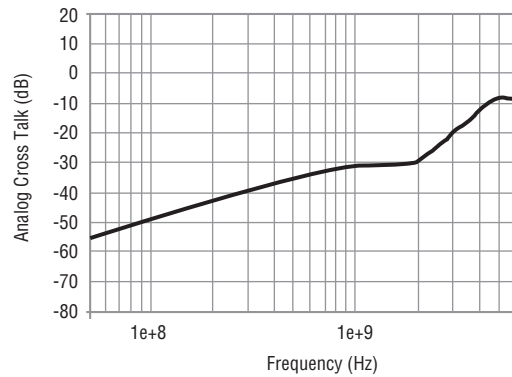

Typical Transmission Line Pulsing (TLP)

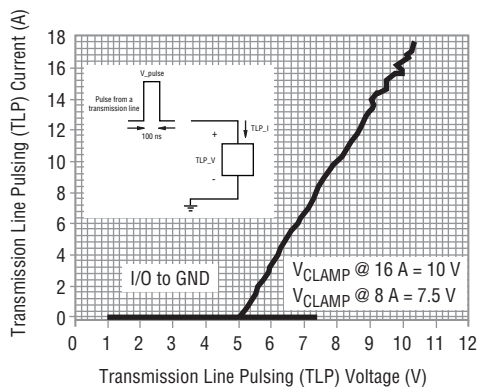

Specifications are subject to change without notice.
The device characteristics and parameters in this data sheet can and do vary in different applications and actual device performance may vary over time.
Users should verify actual device performance in their specific applications.

CDDFN10-3324P - Surface Mount TVS Diode Array



Reference Application

The Bourns® Model CDDFN10-3324P is designed to protect high-speed data ports from ESD transients. For high-speed ports above 5 Gbps such as HDMI 2.0 and USB 3.0, maintaining signal line impedance is a critical requirement. The use of a DFN10 package using a “feed-through” layout provides minimal impedance change on the high-speed data line, while the ultra-low capacitance performance of the device limits signal degradation on each channel.

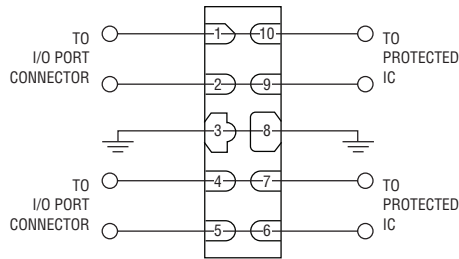

Model CDDFN10-3324P Layout on HDMI Port

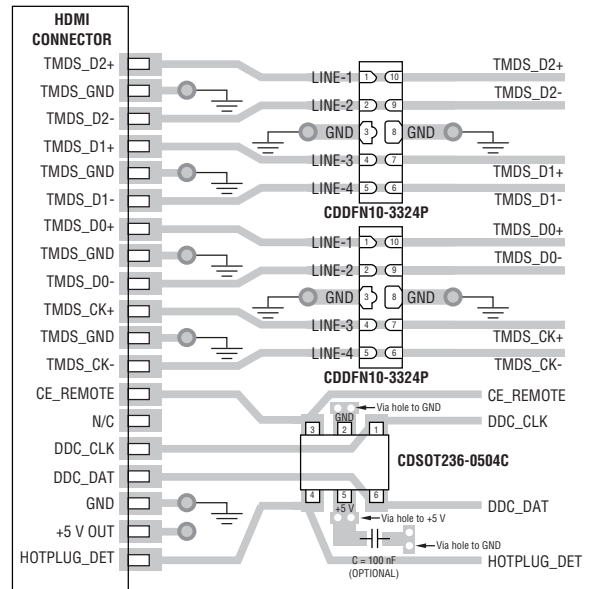

Feed-Through Layout - Model CDDFN10-3324P in HDMI Application

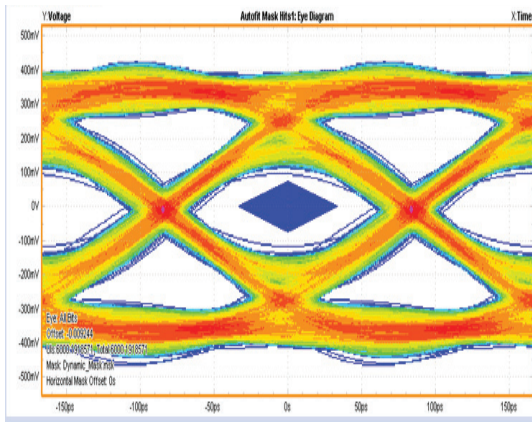

HDMI 2.0 Eye Diagram Test Without Model CDDFN10-3324P (PCB Only)

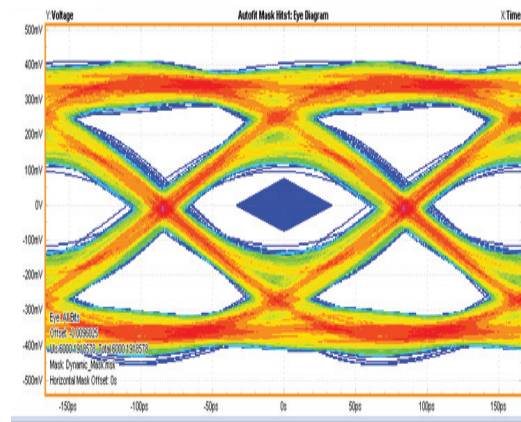

HDMI 2.0 Eye Diagram Test With Model CDDFN10-3324P

Specifications are subject to change without notice. The device characteristics and parameters in this data sheet can and do vary in different applications and actual device performance may vary over time. Users should verify actual device performance in their specific applications.

CDDFN10-3324P - Surface Mount TVS Diode Array

BOURNS®

Packaging Information

The product is packaged in an 8 mm x 4 mm tape and reel format per EIA-481-D standard.

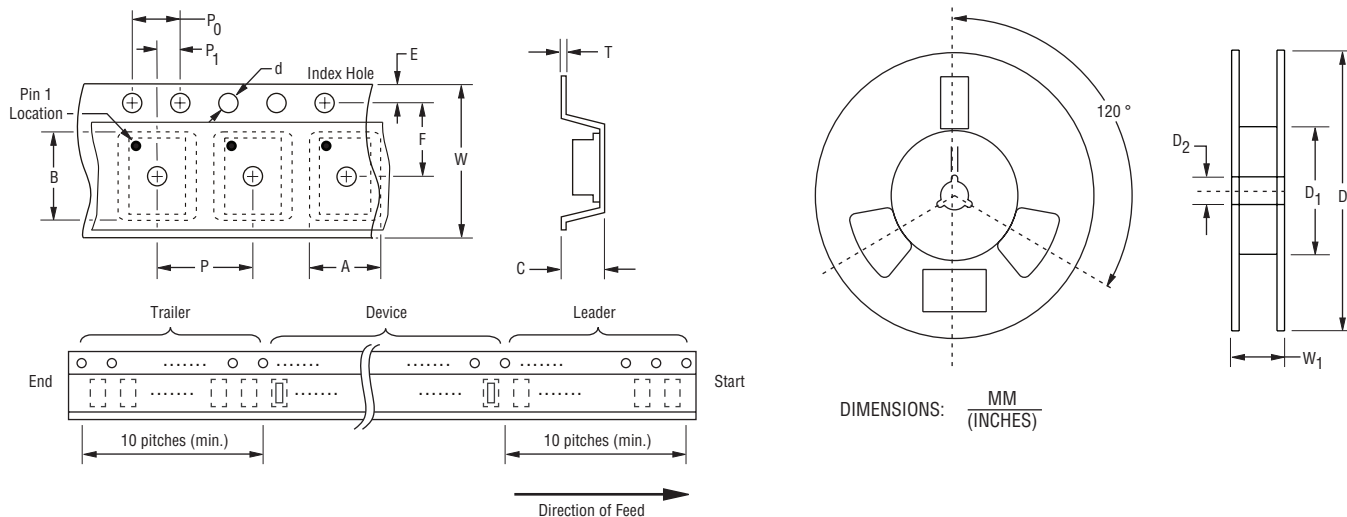

Item	Symbol	DFN-10
Carrier Width	A	$\frac{1.70 \pm 0.08}{(0.067 \pm 0.003)}$
Carrier Length	B	$\frac{2.30 \pm 0.08}{(0.091 \pm 0.003)}$
Carrier Depth	C	$\frac{0.75 \pm 0.05}{(0.030 \pm 0.002)}$
Sprocket Hole	d	$\frac{1.15 \pm 0.10}{(0.045 \pm 0.004)}$
Reel Outside Diameter	D	$\frac{178}{(7.008)}$
Reel Inner Diameter	D ₁	$\frac{54.40 \pm 0.40}{(2.142 \pm 0.016)}$
Feed Hole Diameter	D ₂	$\frac{13.0 \pm 0.20}{(0.512 \pm 0.008)}$
Sprocket Hole Position	E	$\frac{1.75 \pm 0.10}{(0.069 \pm 0.004)}$
Punch Hole Position	F	$\frac{3.50 \pm 0.05}{(0.138 \pm 0.002)}$
Punch Hole Pitch	P	$\frac{4.00 \pm 0.10}{(0.157 \pm 0.004)}$
Sprocket Hole Pitch	P ₀	$\frac{4.00 \pm 0.10}{(0.157 \pm 0.004)}$
Embossment Center	P ₁	$\frac{2.00 \pm 0.05}{(0.079 \pm 0.002)}$
Overall Tape Thickness	T	$\frac{0.20 \pm 0.30}{(0.008 \pm 0.012)}$
Tape Width	W	$\frac{8.00 +0.30/-0.10}{(0.315 +0.012/- 0.004)}$
Reel Width	W ₁	$\frac{12.30 \pm 1.00}{(0.484 \pm 0.039)}$
Quantity per Reel	--	3000

BOURNS®

Asia-Pacific:

Tel: +886-2 2562-4117
Email: asiacus@bourns.com

Europe:

Tel: +36 88 520 390
Email: eurocus@bourns.com

The Americas:

Tel: +1-951 781-5500
Email: americus@bourns.com

www.bourns.com

REV. 04/18

Specifications are subject to change without notice. The device characteristics and parameters in this data sheet can and do vary in different applications and actual device performance may vary over time. Users should verify actual device performance in their specific applications.