

Power Management Switch ICs for PCs and Digital Consumer Products



# Power Switch IC for ExpressCard™

BD4154FV

No.10029EBT09

## ●Description

BD4154FV is a power management switch IC for the next generation PC card (ExpressCard™) developed by the PCMCIA. It conforms to the PCMCIA ExpressCard™ Standard, ExpressCard™ Compliance Checklist, and ExpressCard™ Implementation Guideline, and obtains the Compliance ID "EC100040" from PCMCIA. The power switch offers a number of functions - card detector, and system status detector - which are ideally suited for laptop and desktop computers.

## ●Features

- 1) Incorporates three low on-resistance FETs for ExpressCard™.
- 2) Incorporates an FET for output discharge.
- 3) Incorporates an enabler.
- 4) Incorporates under voltage lockout (UVLO) protection.
- 5) Employs an SSOP-B20 package.
- 6) Built-in thermal shutdown protector (TSD).
- 7) Built-in soft start function.
- 8) Incorporates an overcurrent protection (OCP).
- 9) Built-in enable signal for PLL
- 10) Built-in Pull up resistance for detecting ExpressCard™
- 11) Conforms to the ExpressCard™ Standard.
- 12) Conforms to the ExpressCard™ Compliance Checklist.
- 13) Conforms to the ExpressCard™ Implementation Guideline.



## ●Applications

Laptop and desktop computers, and other ExpressCard™ equipped digital devices.

## ●Product Lineup

Parameter	BD4154FV
Package	SSOP-B20

\*ExpressCard™ is a registered trademark registered of the PCMCIA (Personal Computer Memory Card International Association).

### ●Absolute Maximum Ratings

Parameter	Symbol	Limit	Unit
Input Voltage	V3AUX_IN, V3_IN, V15_IN	-0.3~5.0 <sup>*1</sup>	V
Logic Input Voltage 1	EN,CPPE#,CPUSB#,SYSR, PERST_IN#,RCLKEN	-0.3~V3AUX_IN+0.3 <sup>*1</sup>	V
Logic Output Voltage 1	RCLKEN	-0.3~V3AUX_IN+0.3 <sup>*1</sup>	V
Logic Output Voltage 2	PERST#	-0.3~V3AUX_IN+0.3	V
Output Voltage	V3AUX,V3, V15	-0.3~5.0 <sup>*1</sup>	V
Output Current 1	IOV3AUX	1.0	A
Output Current 2	IOV3	2.0	A
Output Current 3	IOV15	2.0	A
Power Dissipation 1	Pd1	500.0 <sup>*2</sup>	mW
Power Dissipation 2	Pd2	812.5 <sup>*3</sup>	mW
Operating Temperature Range	Topr	-40~+100	°C
Storage Temperature Range	Tstg	-55~+150	°C
Maximum Junction Temperature	Tjmax	+150	°C

<sup>\*1</sup> Not to exceed Pd.

<sup>\*2</sup> Reduced by 4.0mW for each increase in Ta of 1°C over 25°C

<sup>\*3</sup> Reduced by 6.5mW for each increase in Ta of 1°C over 25°C(When mounted on a board 70mmx70mmx1.6mm Glass-epoxy PCB)

### ●Operating Conditions (Ta=25°C)

Parameter	Symbol	MIN	MAX	Unit
Input Voltage 1	V3AUX_IN	3.0	3.6	V
Input Voltage 2	V3_IN	3.0	3.6	V
Input Voltage 3	V15_IN	1.35	1.65	V
Logic Input Voltage 1	EN	-0.3	3.6	V
Logic Input Voltage 2	CPPE#,CPUSB#,SYSR, PERST_IN#,RCLKEN	0	V3AUX_IN	V
Logic Output Voltage 1	RCLKEN	0	V3AUX_IN	V
Logic Output Voltage 2	PERST#	0	V3AUX_IN	V
Output Current 1	IOV3AUX	0	275	mA
Output Current 2	IOV3	0	1.3	A
Output Current 3	IOV15	0	650	mA

\* This product is not designed to offer protection against radioactive rays.

**●Electrical Characteristics (unless otherwise noted, Ta=25°C VEN=3.3V V3AUX\_IN =V3\_IN=3.3V,V15\_IN=1.5V)**

Parameter	Symbol	Standard Value			Unit	Condition	
		MIN	TYP	MAX			
Standby Current	IST	-	40	80	μA	VEN=0V (Include IEN, IRCLKEN)	
Bias Current 1	Icc1	-	120	250	μA	VSYSR=0V	
Bias Current 2	Icc2	-	250	500	μA	VSYSR=3.3V	
[Enable]							
High Level Enable Input Voltage	VENHI	2.0	-	5.5	V		
Low Level Enable Input Voltage	VENLOW	-0.2	-	0.8	V		
Enable Pin Input Current	IEN	10	-	30	μA	VEN=0V	
[Logic]							
High Level Logic Input Voltage	VLHI	2.0	-	-	V		
Low Level Logic Input Voltage	VLOW	-	-	0.8	V		
Logic Pin Input Current	ICPPE#	-	0	1	μA	CPPE#=3.6V	
		10	-	30	μA	CPPE#=0V	
	ICPUSB#	-	0	1	μA	CPUSB#=3.6V	
		10	-	30	μA	CPUSB#=0V	
	ISYSR	-	0	1	μA	SYSR=3.6V	
		10	-	30	μA	SYSR=0V	
	IPRT_IN#	-	0	1	μA	PERST_IN#=3.6V	
		10	-	30	μA	PERST_IN#=0V	
	IRCLKEN	-	0	1	μA	RCLKEN=3.6V	
		10	-	30	μA	RCLKEN=0V	
	RCLKEN Low Voltage	VRCLKEN	-	0.1	0.3	V	IRCLKEN=0.5mA
	RCLKEN Leak Current	IRCLKEN	-	-	1	μA	VRCLKEN=3.65V
[Switch V3AUX]							
On Resistance	R <sub>V3AUX</sub>	-	120	220	mΩ	Tj=-10~100°C *	
Discharge On Resistance	R <sub>V3AUX</sub> Dis	-	60	150	Ω		
[Switch V3]							
On Resistance	R <sub>V3</sub>	-	42	90	mΩ	Tj=-10~100°C *	
Discharge On Resistance	R <sub>V3</sub> Dis	-	60	150	Ω		
[Switch V15]							
On Resistance	R <sub>V15</sub>	-	45	90	mΩ	Tj=-10~100°C *	
Discharge On Resistance	R <sub>V15</sub> Dis	-	60	150	Ω		
[Over Current Protection]							
V3 Over Current	OCP <sub>V3</sub>	1.3	-	-	A		
V3AUX Over Current	OCP <sub>V3AUX</sub>	0.275	-	-	A		
V15 Over Current	OCP <sub>V15</sub>	0.65	-	-	A		
[Under Voltage Lockout]							
V3_IN UVLO OFF Voltage	VUVLO <sub>V3_IN</sub>	2.70	2.80	2.90	V	sweep up	
V3_IN Hysteresis Voltage	ΔVUVLO <sub>V3_IN</sub>	50	100	150	mV	sweep down	
V3AUX_IN UVLO OFF Voltage	VUVLO <sub>V3AUX_IN</sub>	2.70	2.80	2.90	V	sweep up	
V3AUX_IN Hysteresis Voltage	ΔVUVLO <sub>V3AUX_IN</sub>	50	100	150	mV	sweep down	
V15_IN UVLO OFF Voltage	VUVLO <sub>V15_IN</sub>	1.15	1.20	1.25	V	sweep up	
V15_IN Hysteresis Voltage	ΔVUVLO <sub>V15_IN</sub>	50	100	150	mV	sweep down	
[POWER GOOD]							
V3 POWER GOOD Voltage	PG <sub>V3</sub>	2.700	2.850	3.000	V		
V3AUX POWER GOOD Voltage	PG <sub>V3AUX</sub>	2.700	2.850	3.000	V		
V15 POWER GOOD Voltage	PG <sub>V15</sub>	1.200	1.275	1.350	V		
PERST# LOW Voltage	VPERST# <sub>Low</sub>	-	0.1	0.3	V	I <sub>PERST</sub> =0.5mA	
PERST# HIGH Voltage	VPERST# <sub>HIGH</sub>	3.0	-	-	V		
PERST# Delay Time	T <sub>PERST#</sub>	4	-	20	ms		
PERST# assertion time	T <sub>ast</sub>	-	-	500	ns		
[OUTPUT RISE TIME]							
V3_IN to V3	T <sub>V3</sub>	0.1	-	3	ms		
V3AUX_IN to V3AUX	T <sub>V3AUX</sub>	0.1	-	3	ms		
V15_IN to V15	T <sub>V15</sub>	0.1	-	3	ms		

\* Design target

●Reference data

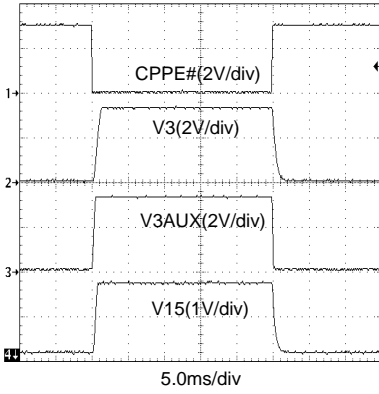

Fig.1 Card Assert/ De-assert (Active)

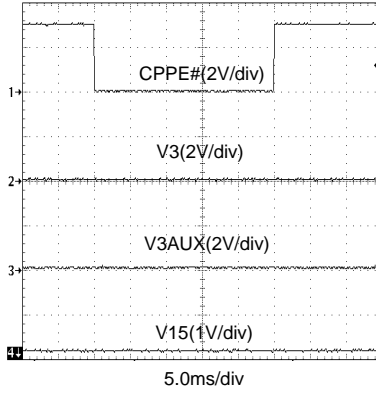

Fig.2 Card Assert/De-assert (Standby)

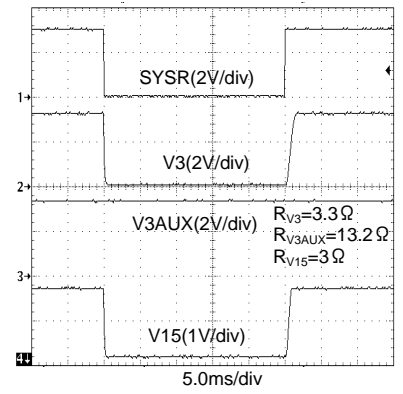

Fig.3 System Active⇔Standby (Card Present)

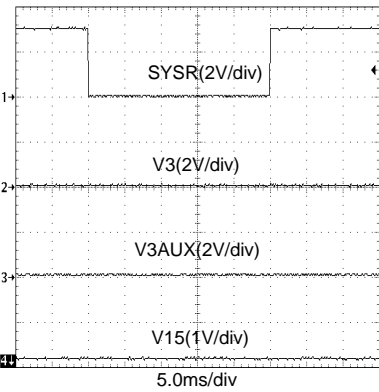

Fig.4 System Active⇔Standby (No Card)

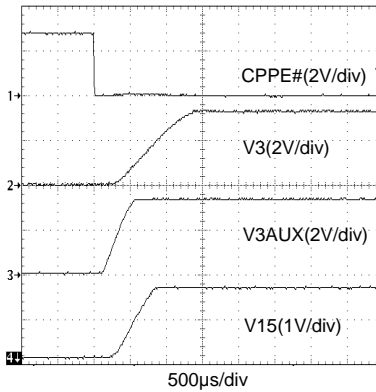

Fig.5 Wakeup Wave Form (Card Assert)

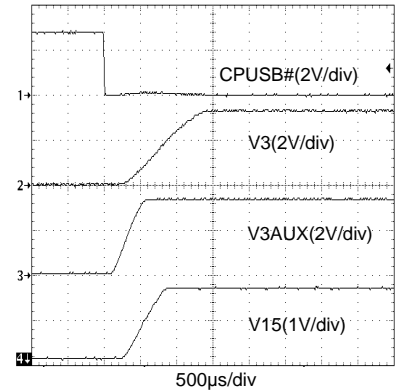

Fig.6 Wakeup Wave Form (USB2.0 Assert)

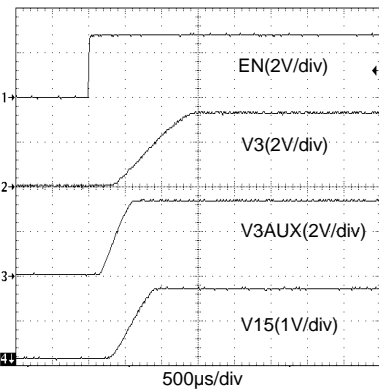

Fig.7 Wakeup Wave Form (Shut Down→Active)

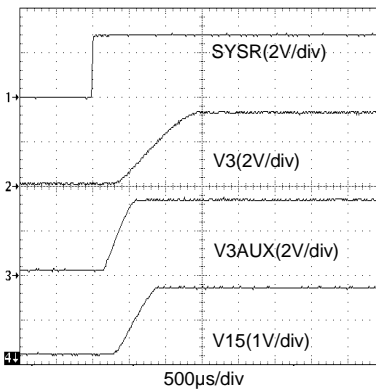

Fig.8 Wakeup Wave Form (Standby→Active)

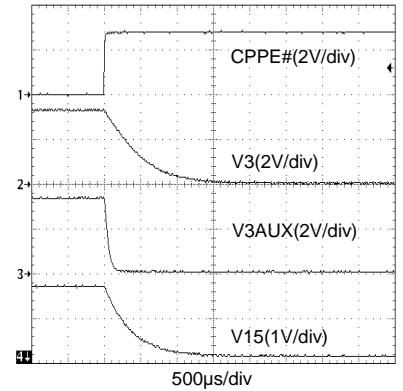

Fig.9 Power Down Wave Form (Card De-assert)

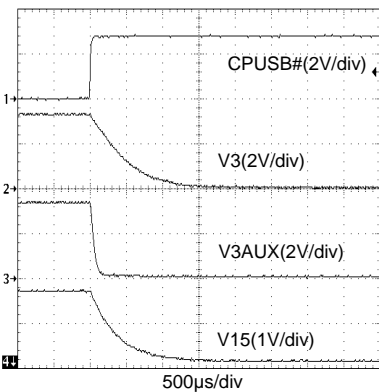

Fig.10 Power Down Wave Form (USB2.0 De-assert)

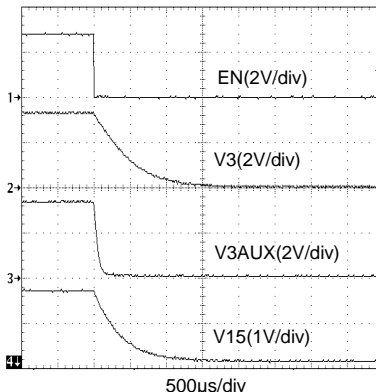

Fig.11 Power Down Wave Form (Active→Shut Down)

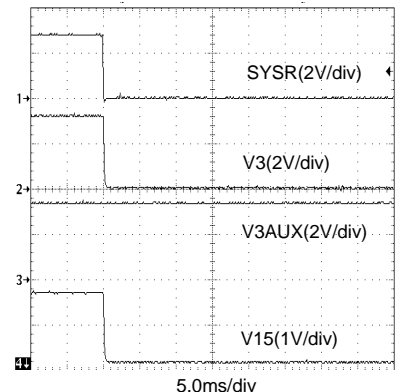

Fig.12 Power Down Wave Form (Active→Standby)

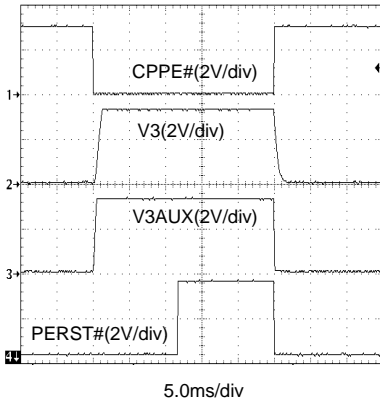

Fig.13 PERST# Wave Form (Card Assert/ De-assert)

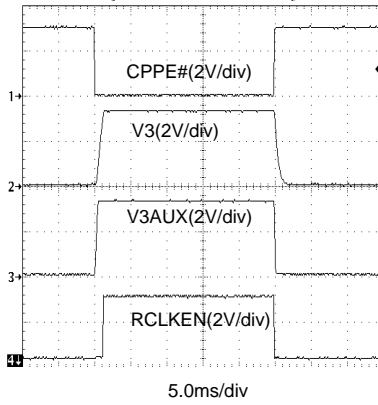

Fig.14 RCLKEN Wave Form (Card Assert/ De-assert)

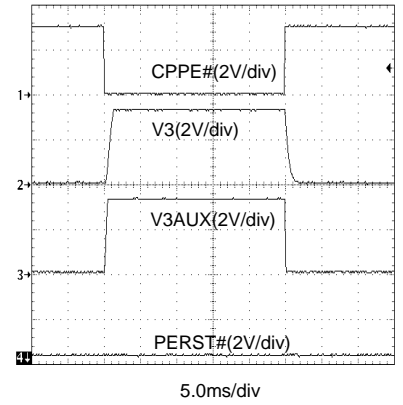

Fig.15 PERST# Wave Form (USB2.0 Assert/ De-assert)

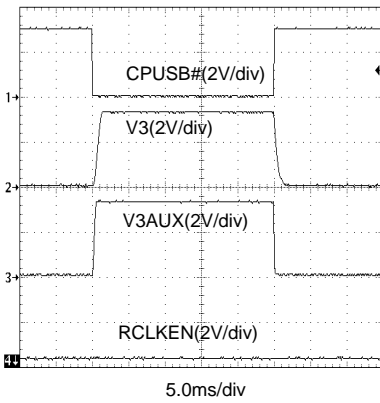

Fig.16 RCLKEN Wave Form (USB2.0 Assert/ De-assert)

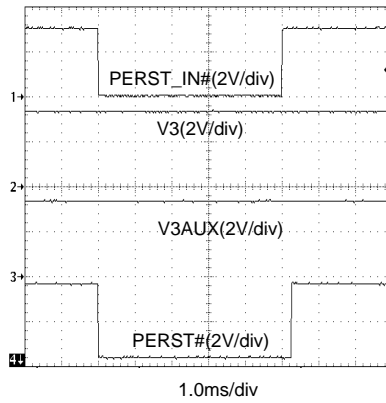

Fig.17 PERST# Wave Form (PERST\_IN# Input)

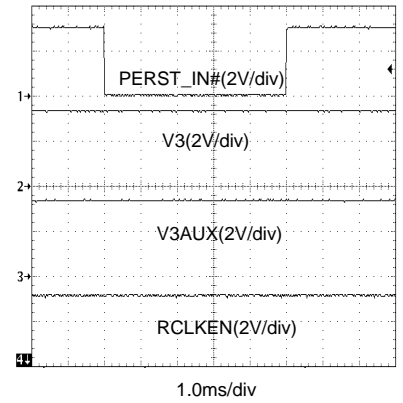

Fig.18 RCLKEN Wave Form (PERST\_IN# Input)

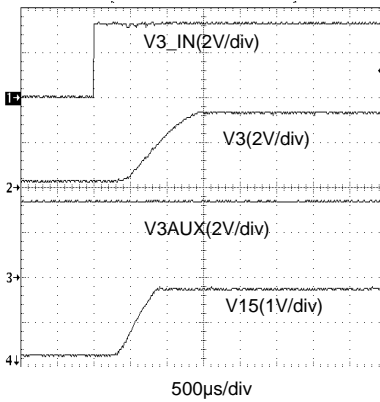

Fig.19 Output Voltage (V3\_IN:OFF→ON)

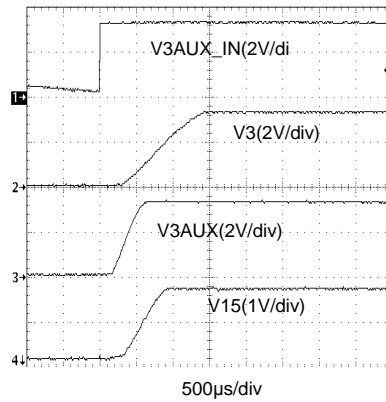

Fig.20 Output Voltage (V3AUX\_IN:OFF→ON)

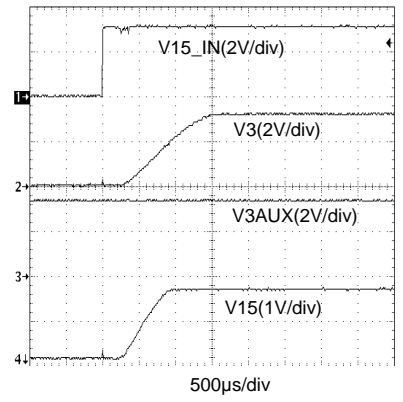

Fig.21 Output Voltage (V15\_IN:OFF→ON)

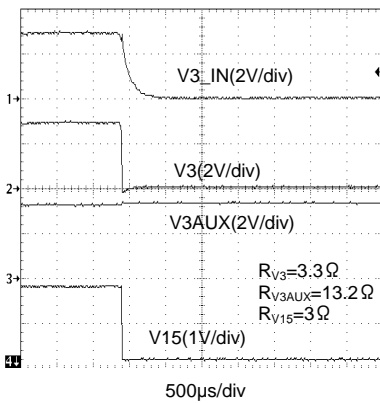

Fig.22 Output Voltage (V3\_IN:ON→OFF)

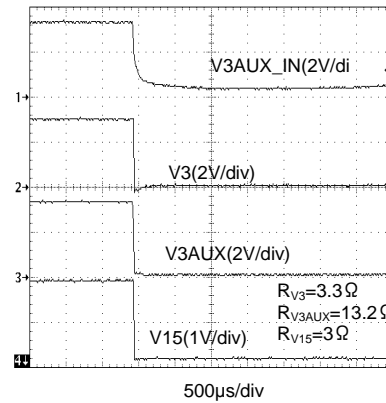

Fig.23 Output Voltage (V3AUX\_IN:ON→OFF)

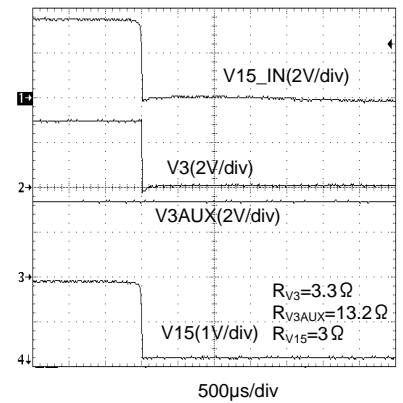
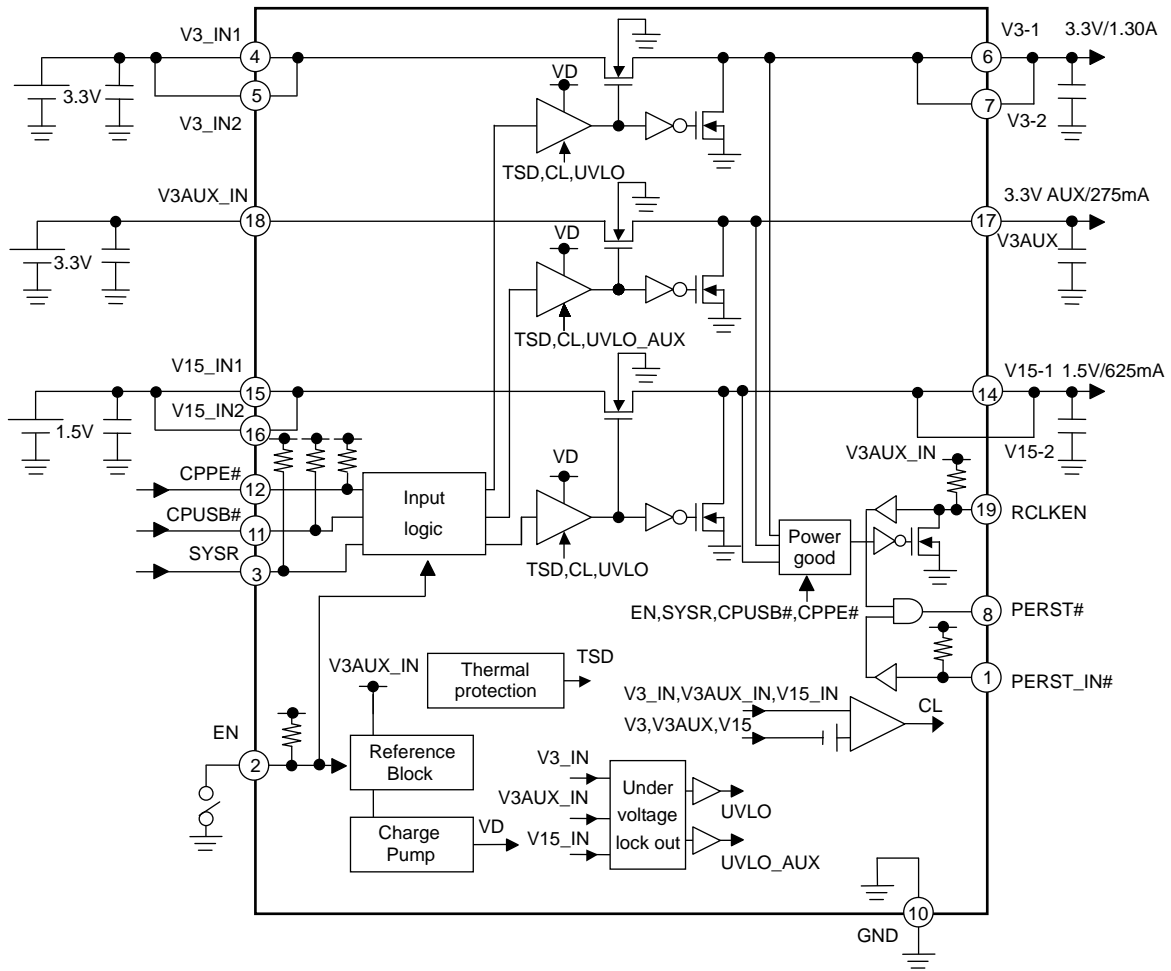

Fig.24 Output Voltage (V15\_IN:ON→OFF)

●Block Diagram



●PIN CONFIGURATION

●PIN FUNCTION

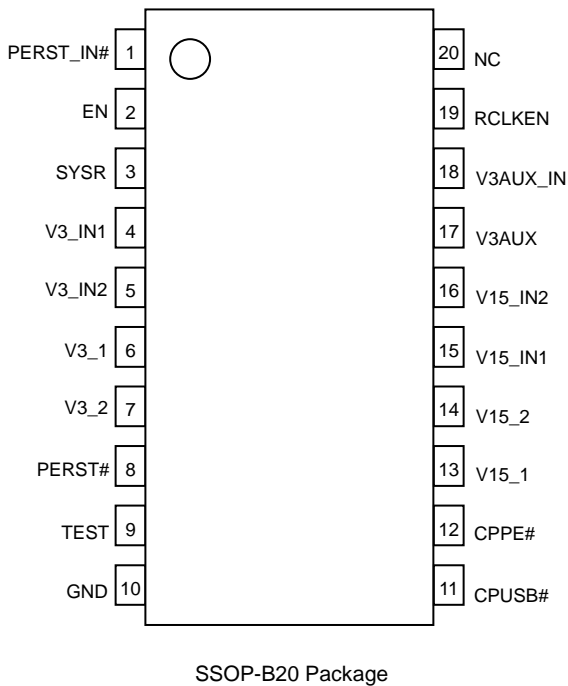

PIN No	PIN NAME	PIN FUNCTION
1	PERST_IN#	PERST# control input pin (SysReset#)
2	EN	Enable input pin
3	SYSR	Logic input pin
4	V3_IN1	V3 input pin 1
5	V3_IN2	V3 input pin 2
6	V3_1	V3 output pin 1
7	V3_2	V3 output pin 2
8	PERST#	Logic output pin
9	TEST	Test pin
10	GND	GND pin
11	CPUSB#	Logic input pin
12	CPPE#	Logic input pin
13	V15_1	V15 output pin 1
14	V15_2	V15 output pin 2
15	V15_IN1	V15 input pin 1
16	V15_IN2	V15 input pin 2
17	V3AUX	V3AUX output pin
18	V3AUX_IN	V3AUX input pin 1
19	RCLKEN	Reference clock enable signal/ Power good signal (No delay)
20	NC	Non connection

**●Description of block operation****EN**

With an input of 2.0 volts or higher, this terminal goes HIGH to activate the circuit, and goes LOW to deactivate the circuit (with the standby circuit current of 40  $\mu$ A). It discharges each output and lowers output voltage when the input falls to 0.8 volts or less.

**V3\_IN, V15\_IN, and V3AUX\_IN**

These are the input terminals for each channel of a 3ch switch. V3\_IN and V15\_IN terminals have two pins each, which should be short-circuited on the pc board with a thick conductor. A large current runs through these three terminals : (V3\_IN: 1.35A; V3AUX\_IN: 0.275 A; and V15\_IN: 0.625 A). In order to lower the output impedance of the connected power supply, it is recommended that ceramic capacitors (with B-type characteristics or better) be provided between these terminals and the ground. Specifically, the capacitors should be on the order of 1  $\mu$ F between V3\_IN and GND, and between V15\_IN and GND; and on the order of 0.1  $\mu$ F between V3AUX\_IN and GND.

**V3, V15, and V3AUX**

These are the output terminals for each switch. The V3 and V15 terminals have two pins each, which should be short-circuited on the PC board and connected to an ExpressCard connector with a thick conductor, as short as possible. In order to stabilize the output, it is recommended that ceramic capacitors (with B-type characteristics or better) be provided between these terminals and the ground. Specifically, the capacitors should be on the order of 10  $\mu$ F between V3 and GND, and between V15 and GND; and on the order of 1  $\mu$ F between V3AUX and GND.

**CPPE#**

This pin is used to find whether or not a PCI-Express signal compatible card is present. Turns to "High" level with an input of 2.0 volts or higher, which means that no card is provided, while it turns to "Low" level when the input is lowered to 0.8 volts or less, which means that a card is provided. Controls the ON/OFF, switch selecting the proper mode based on the status of the system.

Pull up resistance (100k $\Omega$  ~200k $\Omega$ ) is built into, so the number of components is reduced.

**CPUSB#**

This pin is used to find whether or not a USB2.0 signal compatible card is present. Turns to "High" level with an input of 2.0 volts or higher, which means that no card is provided, while it turns to "Low" level when the input is lowered to 0.8 volts or less, which means that a card is provided. Controls the ON/OFF switch, selecting the proper mode based on the system status.

Pull up resistance (100k $\Omega$  ~200k $\Omega$ ) is built into, so the number of components is reduced.

**SYSR**

This pin is used to detect the system status. Turns to "High" level with an input of 2.0 volts or higher, which means that the system is activated, while it turns to "Low" level when the input is lowered to 0.8 volts or less, which means that the system is on standby.

**PERST\_IN#**

This pin is used to control the reset signal (PERST#) to a card from the system side. (Also referred to as "SysReset#" by PCMCIA.) Turns to "High" level with an input of 2.0 volts or higher, and sets PERST# to "High" AND with a "Power Good" output. Turns to "Low" level and sets PERST# to "Low" when the input falls to 0.8 volts or less.

**PERST#**

This pin is used to send a reset signal to a PCI-Express compatible card. Reset status is determined by the outputs, PERST\_IN#, CPPE# system status, and EN on/off status. Turns to "High" level and activates the PCI-Express compatible card only if each output is within the "Power Good" threshold, with the card inserted and PERST\_IN# turned to "High" level.

**RCLKEN**

This pin is used to send an enable signal to the reference clock. Activation status is determined by the outputs, CPPE# system status, and EN on/off status. Turns to "High" level and activates the reference clock PLL only if each output is within the "Power Good" threshold, with the card kept inserted.

**TEST**

This pin is used to test, which should be short-circuited to the GND. When it is short-circuited to V3AUX\_IN, UVLO (V3\_IN, V15\_IN) turns OFF.

●Timing Chart

Power ON/OFF Status of ExpressCard™

System Status		ExpressCard™ Module Status	Power Switch Status	
Primary	Auxiliary		Primary(+3.3V and +1.5V)	Auxiliary(3.3V Aux)
OFF	OFF	Don't care	OFF	OFF
ON	ON	De-asserted	OFF	OFF
		Asserted	ON	ON
ON	ON	De-asserted	OFF	OFF
		Asserted Before This	OFF	ON
		Asserted After This	OFF	OFF

ExpressCard™ States Transition Diagram

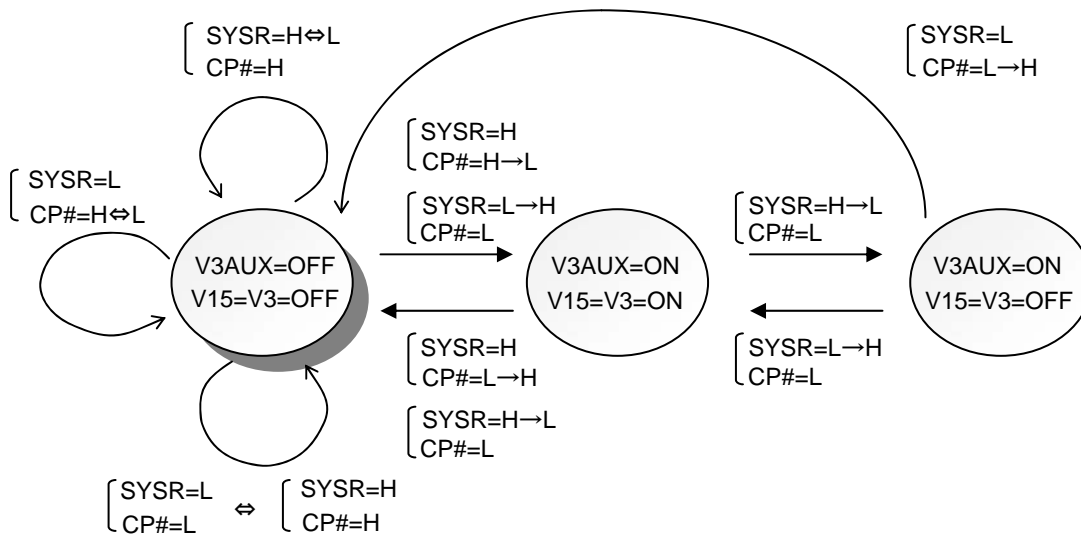

System Status		Card Status	
Stand-by Status	:SYSR=L	Card Asserted Status	:CP#=L
ON Status	:SYSR=H	Card De-asserted Status	:CP#=H
From ON to Stand-by Status	:SYSR=H→L	From De-asserted to Asserted Status	:CP#=H→L
From Stand-by to ON Status	:SYSR=L→H	From Asserted to De-asserted Status	:CP#=L→H



■ BD4154FV Evaluation Board

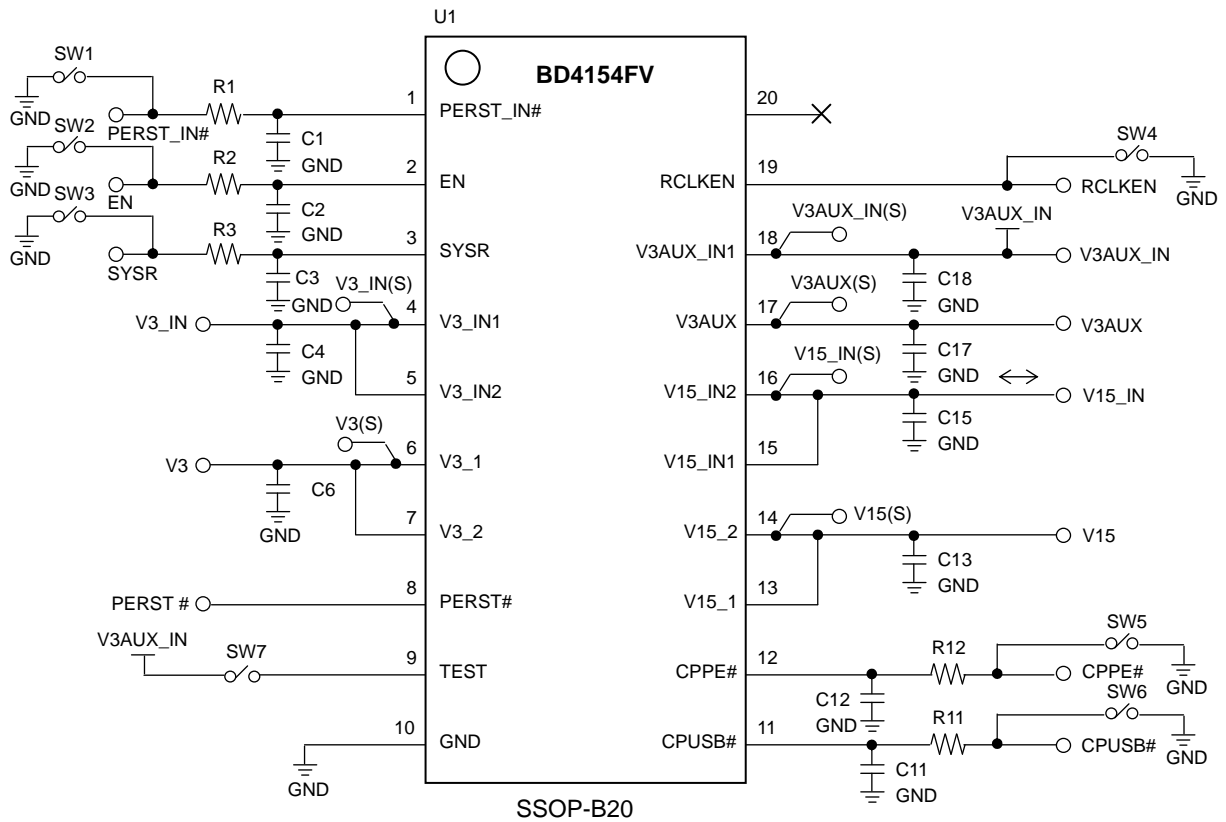

■ BD4154FV Evaluation Board Application Components

Part No	Value	Company	Part Name
R1	0Ω	ROHM	MCR03series
R2	0Ω	ROHM	MCR03series
R3	0Ω	ROHM	MCR03series
R11	0Ω	ROHM	MCR03series
R12	0Ω	ROHM	MCR03series
C1	-	-	-
C2	-	-	-
C3	-	-	-
C4	1μF	murata	GMR21 series
C6	10μF	murata	GMR21 series
C11	-	-	-
C12	-	-	-
C13	10μF	murata	GMR21 series
C15	1μF	murata	GMR21 series
C17	1μF	murata	GMR21 series
C18	0.1μF	murata	GMR18 series

■ BD4154FV Evaluation Board Layout

Silk Screen

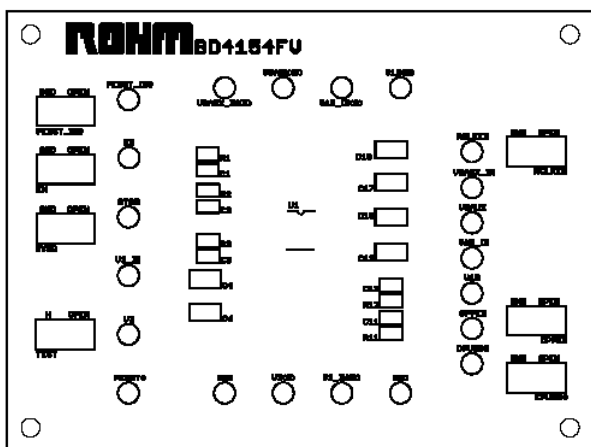

TOP Layer

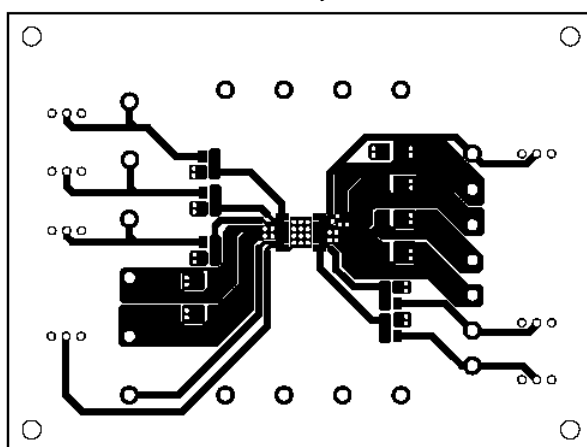

Mid Layer 1

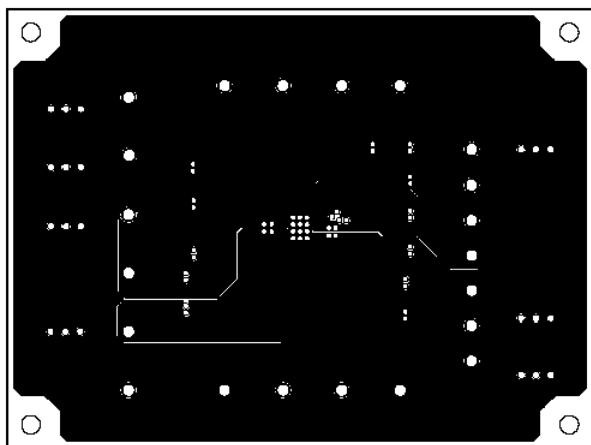

Mid Layer 2

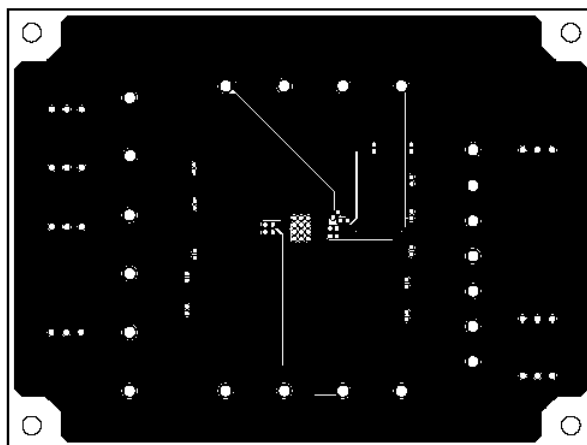

Bottom Layer

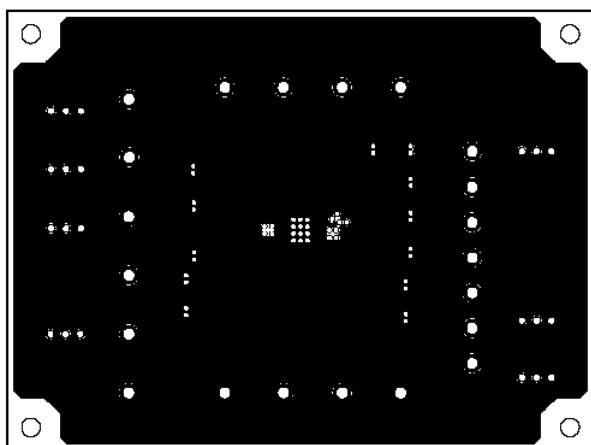

●Application Circuit (Circuit for ExpressCard™ Compliance Checklist)

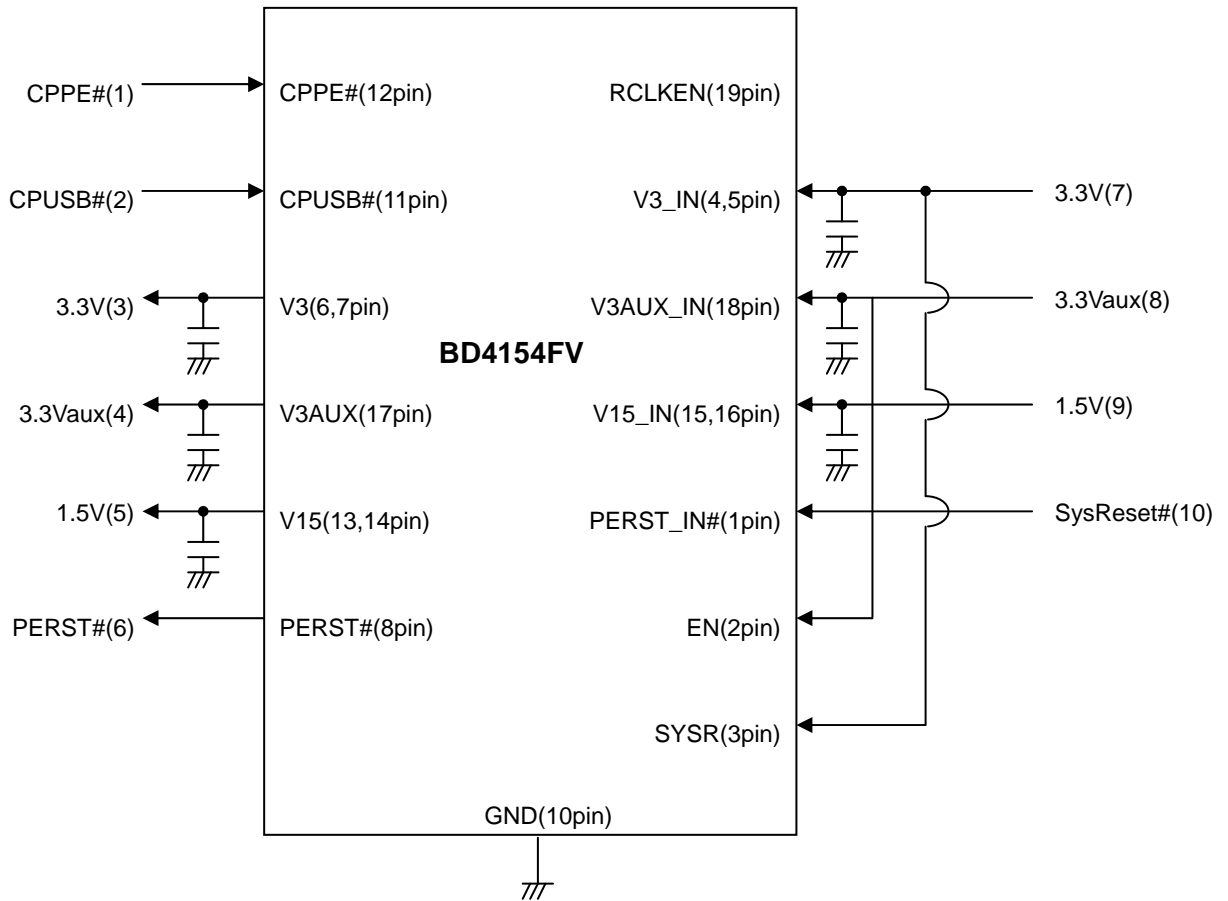

●Heat loss

Thermal design should allow the device to operate within the following conditions. Note that the temperatures listed are the allowed temperature limits. Thermal design should allow sufficient margin from these limits.

1. Ambient temperature  $T_a$  can be no higher than 100°C.
2. Chip junction temperature  $T_j$  can be no higher more than 150°C.

Chip junction temperature  $T_j$  can be determined as follows:

①Chip junction temperature  $T_j$  is calculated from IC surface temperature  $T_C$  under actual application conditions:

$$T_j = T_C + \theta_{j-c} \times W$$

<Reference value>

$$\theta_{j-c}: \text{SSOP-B20} \quad 35 \text{ } ^\circ\text{C/W}$$

②Chip junction temperature  $T_j$  is calculated from ambient temperature  $T_a$ :

$$T_j = T_a + \theta_{j-a} \times W$$

<Reference value>

$$\theta_{j-a}: \text{SSOP-B20} \quad \begin{array}{l} 250^\circ\text{C/W (IC only)} \\ 153.8^\circ\text{C/W Single-layer substrate} \\ \text{(substrate surface copper foil area: less than 3\%)} \end{array}$$

Most of heat loss in the BD4154FV occurs at the output switch. The power lost is determined by multiplying the on-resistance by the square of output current of each switch.

●Equivalent Circuit

1pin<PERST\_IN#>

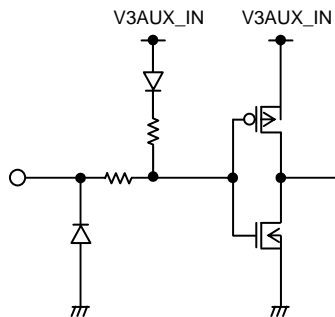

2pin<EN>

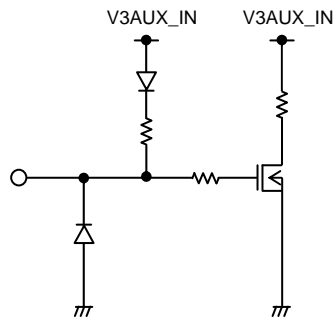

3pin<SYSR>

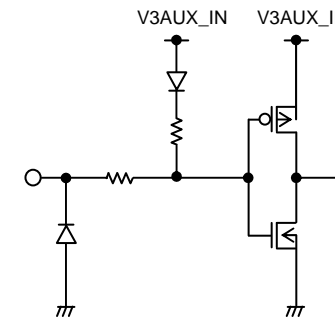

4,5pin<V3\_IN1,V3\_IN2>

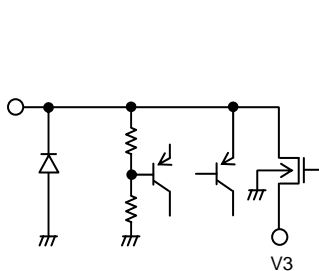

6,7pin<V3\_1,V3\_2>

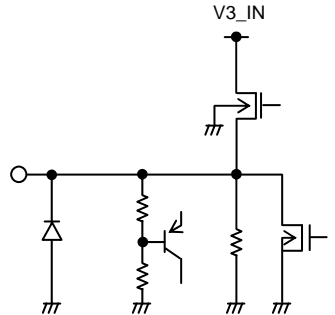

8pin<PERST#>

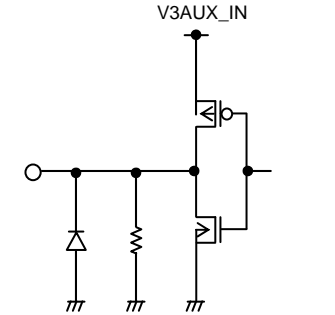

9pin<TEST>

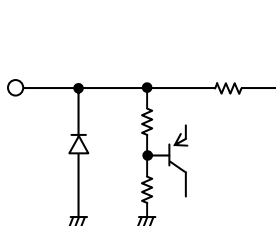

11pin<CPUSB#>

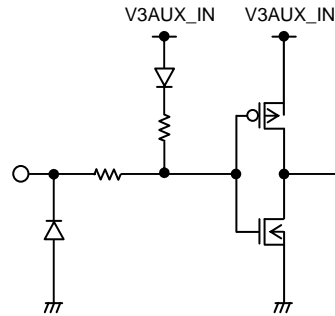

12pin<CPPE#>

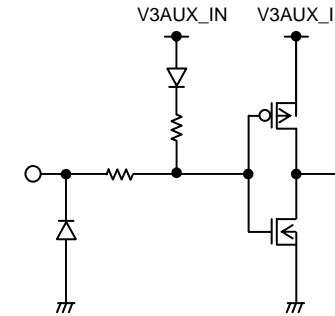

13,14pin<V15\_1,V15\_2>

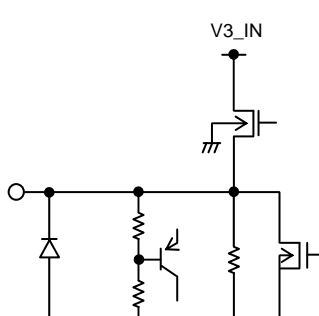

15,16pin<V15\_IN1,V15\_IN2>

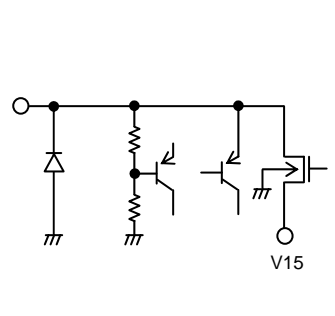

17pin<V3AUX>

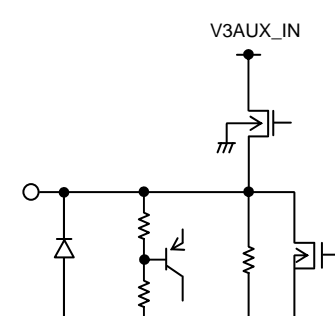

18pin<V3AUX\_IN#>

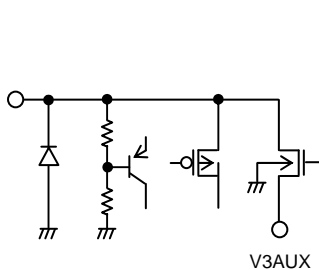

19pin<RCLKEN >

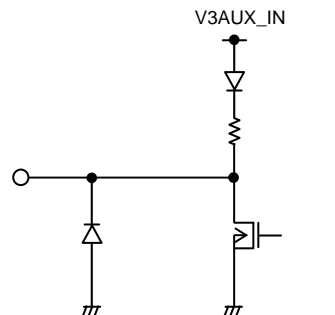

●Notes for Use

1. Absolute maximum ratings

Although quality is rigorously controlled, the device may be destroyed when applied voltage, operating temperature, etc. exceeds its absolute maximum rating. Because the source (short mode or open mode) cannot be identified once the IC is destroyed, it is important to take physical safety measures such as fusing when implementing any special mode that operates in excess of absolute rating limits.

2. Thermal design

Consider allowable loss (Pd) under actual operating conditions and provide sufficient margin in the thermal design.

3. Terminal-to-terminal short-circuit and mis-mounting

When the mounting the IC to a printed circuit board, take utmost care to assure the position and orientation of the IC are correct. In the event that the IC is mounted erroneously, it may be destroyed. The IC may also be destroyed when a short-circuit is caused by foreign matter introduced into the clearance between outputs, or between an output and power-GND.

4. Operation in strong electromagnetic fields

Using the IC in strong electromagnetic fields may cause malfunctions. Exercise caution in respect to electromagnetic fields.

5. Built-in thermal shutdown protection circuit

This IC incorporates a thermal shutdown protection circuit (TSD circuit). The working temperature is 175°C (standard value) with a -15°C (standard value) hysteresis width. When the IC chip temperature rises the TSD circuit is activated, while the output terminal is brought to the OFF state. The built-in TSD circuit is intended exclusively to shut down the IC in a thermal runaway event, and is not intended to protect the IC or guarantee performance in these conditions. Therefore, do not operate the IC after with the expectation of continued use or subsequent operation once this circuit is activated.

6. Capacitor across output and GND

When a large capacitor is connected across the output and GND, and the V3AUX\_IN is short-circuited with 0V or GND for any reason, current charged in the capacitor flows into the output and may destroy the IC. Therefore, use a capacitor smaller than 1000 µF between the output and GND.

7. Set substrate inspection

Connecting a low-impedance capacitor to a pin when running an inspection with a set substrate may produce stress on the IC. Therefore, be certain to discharge electricity at each process of the operation. To prevent electrostatic accumulation and discharge in the assembly process, thoroughly ground yourself and any equipment that could sustain ESD damage, and continue observing ESD-prevention procedures in all handling, transfer and storage operations. Before attempting to connect the set substrate to the test setup, make certain that the power supply is OFF. Likewise, be sure the power supply is OFF before removing the substrate from the test setup.

8. IC terminal input

This integrated circuit is a monolithic IC, with P substrate and P<sup>+</sup> isolation between elements.

The P layer and N layer of each element form a PN junction. When the potential relation is GND > terminal A > terminal B, the PN junction works as a diode, and when terminal B > GND > terminal A, the PN junction operates as a parasitic transistor. Parasitic elements inevitably form, due to the nature of the IC construction. The operation of the parasitic element gives rise to mutual interference between circuits and results in malfunction, and eventually, breakdown. Consequently, take utmost care not to use the IC in a way that would cause the parasitic element to actively operate, such as applying voltage lower than GND (P substrate) to the input terminal.

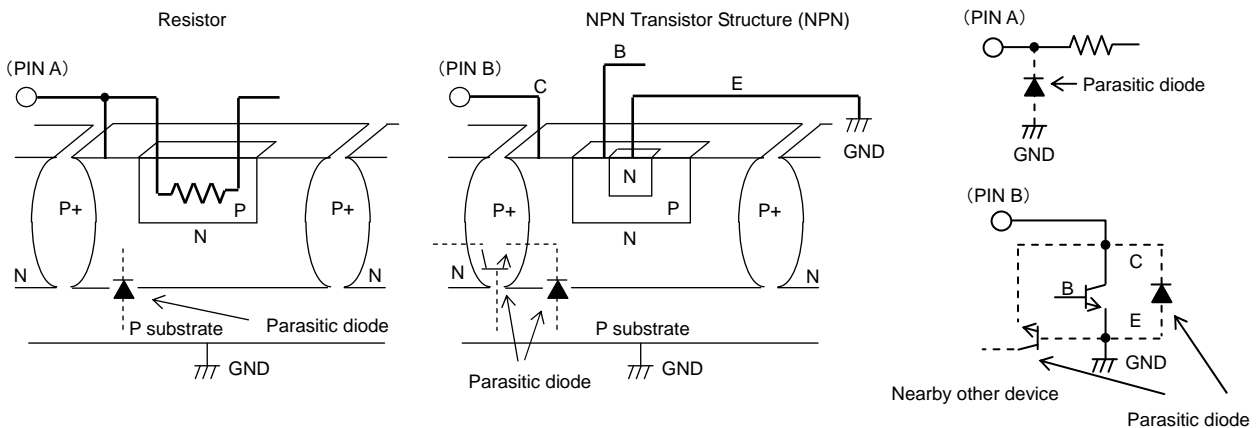

9. GND wiring pattern

If both a small signal GND and a high current GND are present, it is recommended that the patterns for the high current GND and the small signal GND be separated. Proper grounding to the reference point of the set should also be provided. In this way, the small signal GND voltage will be unaffected by the change in voltage stemming from the pattern wiring resistance and the high current. Also, pay special attention to avoid undesirable wiring pattern fluctuations in any externally connected GND component.

10. Electrical characteristics

The electrical characteristics in the Specifications may vary, depending on ambient temperature, power supply voltage, circuit(s) externally applied, and/or other conditions. Therefore, please check all such factors, including transient characteristics, that could affect the electrical characteristics.

11. Capacitors applied to input terminals

The capacitors applied to the input terminals (V3\_IN, V3AUX\_IN and V15\_IN) are used to lower the output impedance of the connected power supply. An increase in the output impedance of the power supply may result in destabilization of input voltages (V3\_IN, V3AUX\_IN and V15\_IN). It is recommended that a low-ESR capacitor be used, with a lower temperature coefficient (change in capacitance vs. change in temperature). Recommended capacitors are on the order of 0.1 μF for V3AUX\_IN, and 1 μF for V3\_IN and V15\_IN. However, they must be thoroughly checked at the temperature and with the load range expected in actual use, because capacitor selection depends to a significant degree on the characteristics of the input power supply to be used and the conductor pattern of the PC board.

12. Capacitors applied to output terminals

Capacitors for the output terminals (V3, V3\_AUX, and V15), should be connected between each of the output terminals and GND. A low-ESR, low temperature coefficient output capacitor is recommended-on the order of 1 μF for V3 and V15 terminals, and 1 μF less for V3\_AUX. However, they must be thoroughly checked at the temperature and with the load range expected in actual use, because capacitor selection depends to a significant degree on the temperature and the load conditions.

13. Not of a radiation-resistant design.

14. Allowable loss (Pd)

With respect to the allowable loss, please refer to the thermal derating characteristics shown in the Exhibit, which serves as a rule of thumb. When the system design causes the IC to operate in excess of the allowable loss, chip temperature will rise, reducing the current capacity and decreasing other basic IC functionality. Therefore, design should always enable IC operation within the allowable loss only.

15. Operating range

Basic circuit functions and operations are warranted within the specified operating range the working ambient temperature range. Although reference values for electrical characteristics are not warranted, no rapid or extraordinary changes in these characteristics are expected, provided operation is within the normal operating and temperature range.

16. The applied circuit example diagrams presented here are recommended configurations. However, actual design depends on IC characteristics, which should be confirmed before operation. Also, note that modifying external circuits may impact static, noise and other IC characteristics, including transient characteristics. Be sure to allow sufficient margin in the design to accommodate these factors.

17. Wiring to the input terminals (V3 IN, V3AUX IN, and V15 IN) and output terminals (V3, V3AUX and V15) of the built-in FET should be carried out with special care. Using unnecessarily long and/or thin conductors may decrease output voltage and degrade other characteristics.

18. Heatsink

The heatsink is connected to the SUB, which should be short-circuited to the GND. Proper heatsink soldering to the PC board should enable lower thermal resistance.

●Power Dissipation

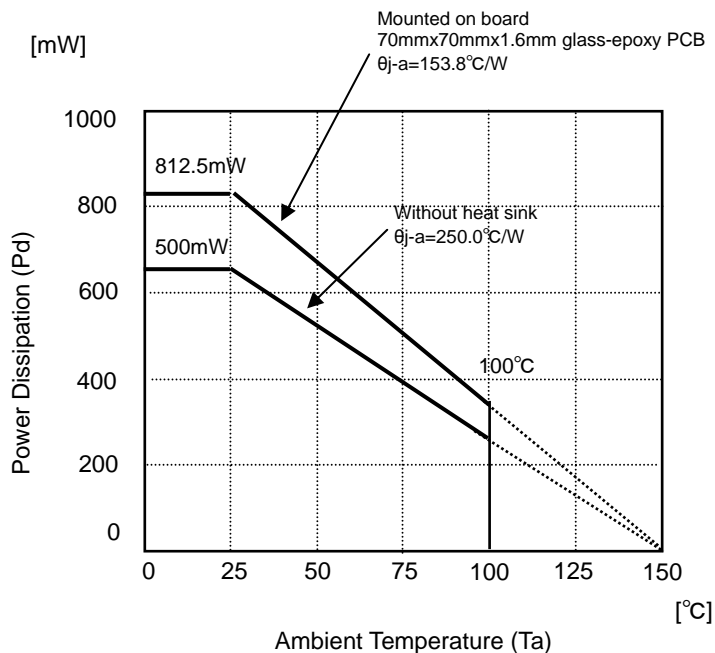

●Ordering part number

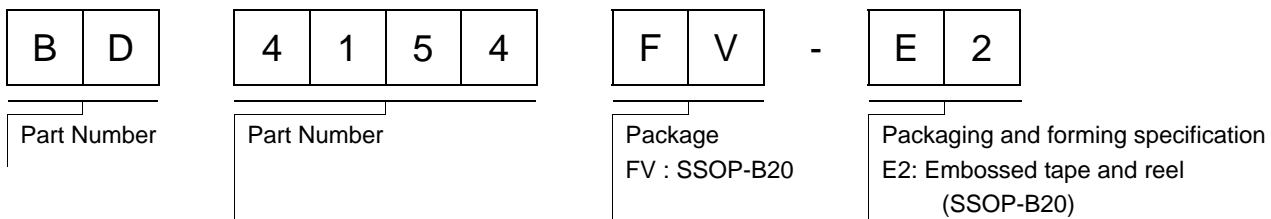

SSOP-B20

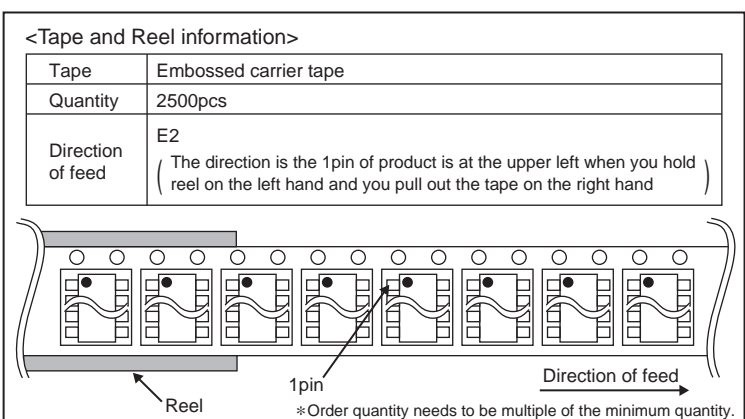
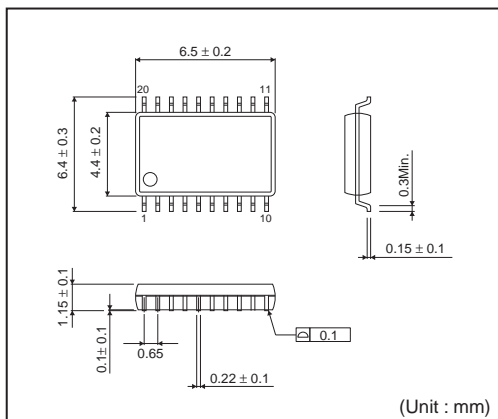

# Notice

## Precaution on using ROHM Products

- Our Products are designed and manufactured for application in ordinary electronic equipments (such as AV equipment, OA equipment, telecommunication equipment, home electronic appliances, amusement equipment, etc.). If you intend to use our Products in devices requiring extremely high reliability (such as medical equipment <sup>(Note 1)</sup>, transport equipment, traffic equipment, aircraft/spacecraft, nuclear power controllers, fuel controllers, car equipment including car accessories, safety devices, etc.) and whose malfunction or failure may cause loss of human life, bodily injury or serious damage to property ("Specific Applications"), please consult with the ROHM sales representative in advance. Unless otherwise agreed in writing by ROHM in advance, ROHM shall not be in any way responsible or liable for any damages, expenses or losses incurred by you or third parties arising from the use of any ROHM's Products for Specific Applications.

(Note1) Medical Equipment Classification of the Specific Applications

JAPAN	USA	EU	CHINA
CLASS III	CLASS III	CLASS II b	CLASS III
CLASS IV		CLASS III	

- ROHM designs and manufactures its Products subject to strict quality control system. However, semiconductor products can fail or malfunction at a certain rate. Please be sure to implement, at your own responsibilities, adequate safety measures including but not limited to fail-safe design against the physical injury, damage to any property, which a failure or malfunction of our Products may cause. The following are examples of safety measures:
  - Installation of protection circuits or other protective devices to improve system safety
  - Installation of redundant circuits to reduce the impact of single or multiple circuit failure
- Our Products are designed and manufactured for use under standard conditions and not under any special or extraordinary environments or conditions, as exemplified below. Accordingly, ROHM shall not be in any way responsible or liable for any damages, expenses or losses arising from the use of any ROHM's Products under any special or extraordinary environments or conditions. If you intend to use our Products under any special or extraordinary environments or conditions (as exemplified below), your independent verification and confirmation of product performance, reliability, etc. prior to use, must be necessary:
  - Use of our Products in any types of liquid, including water, oils, chemicals, and organic solvents
  - Use of our Products outdoors or in places where the Products are exposed to direct sunlight or dust
  - Use of our Products in places where the Products are exposed to sea wind or corrosive gases, including Cl<sub>2</sub>, H<sub>2</sub>S, NH<sub>3</sub>, SO<sub>2</sub>, and NO<sub>2</sub>
  - Use of our Products in places where the Products are exposed to static electricity or electromagnetic waves
  - Use of our Products in proximity to heat-producing components, plastic cords, or other flammable items
  - Sealing or coating our Products with resin or other coating materials
  - Use of our Products without cleaning residue of flux (even if you use no-clean type fluxes, cleaning residue of flux is recommended); or Washing our Products by using water or water-soluble cleaning agents for cleaning residue after soldering
  - Use of the Products in places subject to dew condensation
- The Products are not subject to radiation-proof design.
- Please verify and confirm characteristics of the final or mounted products in using the Products.
- In particular, if a transient load (a large amount of load applied in a short period of time, such as pulse. is applied, confirmation of performance characteristics after on-board mounting is strongly recommended. Avoid applying power exceeding normal rated power; exceeding the power rating under steady-state loading condition may negatively affect product performance and reliability.
- De-rate Power Dissipation (Pd) depending on Ambient temperature (Ta). When used in sealed area, confirm the actual ambient temperature.
- Confirm that operation temperature is within the specified range described in the product specification.
- ROHM shall not be in any way responsible or liable for failure induced under deviant condition from what is defined in this document.

## Precaution for Mounting / Circuit board design

- When a highly active halogenous (chlorine, bromine, etc.) flux is used, the residue of flux may negatively affect product performance and reliability.
- In principle, the reflow soldering method must be used; if flow soldering method is preferred, please consult with the ROHM representative in advance.

For details, please refer to ROHM Mounting specification



### Precautions Regarding Application Examples and External Circuits

1. If change is made to the constant of an external circuit, please allow a sufficient margin considering variations of the characteristics of the Products and external components, including transient characteristics, as well as static characteristics.
2. You agree that application notes, reference designs, and associated data and information contained in this document are presented only as guidance for Products use. Therefore, in case you use such information, you are solely responsible for it and you must exercise your own independent verification and judgment in the use of such information contained in this document. ROHM shall not be in any way responsible or liable for any damages, expenses or losses incurred by you or third parties arising from the use of such information.

### Precaution for Electrostatic

This Product is electrostatic sensitive product, which may be damaged due to electrostatic discharge. Please take proper caution in your manufacturing process and storage so that voltage exceeding the Products maximum rating will not be applied to Products. Please take special care under dry condition (e.g. Grounding of human body / equipment / solder iron, isolation from charged objects, setting of ionizer, friction prevention and temperature / humidity control).

### Precaution for Storage / Transportation

1. Product performance and soldered connections may deteriorate if the Products are stored in the places where:
  - [a] the Products are exposed to sea winds or corrosive gases, including Cl<sub>2</sub>, H<sub>2</sub>S, NH<sub>3</sub>, SO<sub>2</sub>, and NO<sub>2</sub>
  - [b] the temperature or humidity exceeds those recommended by ROHM
  - [c] the Products are exposed to direct sunshine or condensation
  - [d] the Products are exposed to high Electrostatic
2. Even under ROHM recommended storage condition, solderability of products out of recommended storage time period may be degraded. It is strongly recommended to confirm solderability before using Products of which storage time is exceeding the recommended storage time period.
3. Store / transport cartons in the correct direction, which is indicated on a carton with a symbol. Otherwise bent leads may occur due to excessive stress applied when dropping of a carton.
4. Use Products within the specified time after opening a humidity barrier bag. Baking is required before using Products of which storage time is exceeding the recommended storage time period.

### Precaution for Product Label

QR code printed on ROHM Products label is for ROHM's internal use only.

### Precaution for Disposition

When disposing Products please dispose them properly using an authorized industry waste company.

### Precaution for Foreign Exchange and Foreign Trade act

Since our Products might fall under controlled goods prescribed by the applicable foreign exchange and foreign trade act, please consult with ROHM representative in case of export.

### Precaution Regarding Intellectual Property Rights

1. All information and data including but not limited to application example contained in this document is for reference only. ROHM does not warrant that foregoing information or data will not infringe any intellectual property rights or any other rights of any third party regarding such information or data. ROHM shall not be in any way responsible or liable for infringement of any intellectual property rights or other damages arising from use of such information or data.:
2. No license, expressly or implied, is granted hereby under any intellectual property rights or other rights of ROHM or any third parties with respect to the information contained in this document.

### Other Precaution

1. This document may not be reprinted or reproduced, in whole or in part, without prior written consent of ROHM.
2. The Products may not be disassembled, converted, modified, reproduced or otherwise changed without prior written consent of ROHM.
3. In no event shall you use in any way whatsoever the Products and the related technical information contained in the Products or this document for any military purposes, including but not limited to, the development of mass-destruction weapons.
4. The proper names of companies or products described in this document are trademarks or registered trademarks of ROHM, its affiliated companies or third parties.

**General Precaution**

1. Before you use our Products, you are requested to carefully read this document and fully understand its contents. ROHM shall not be in any way responsible or liable for failure, malfunction or accident arising from the use of any ROHM's Products against warning, caution or note contained in this document.
2. All information contained in this document is current as of the issuing date and subject to change without any prior notice. Before purchasing or using ROHM's Products, please confirm the latest information with a ROHM sales representative.
3. The information contained in this document is provided on an "as is" basis and ROHM does not warrant that all information contained in this document is accurate and/or error-free. ROHM shall not be in any way responsible or liable for any damages, expenses or losses incurred by you or third parties resulting from inaccuracy or errors of or concerning such information.