

DO NOT SCALE FROM THIS PRINT

- NOTES:
 1. ITEMS -1, -2, & -3 NOT AVAILABLE AS STANDARD.
 2. Ⓢ REPRESENTS A CRITICAL DIMENSION.
 3. MINIMUM PUSHOUT FORCE: .5 LB.
 4. MAXIMUM ALLOWABLE BOW: TOP/BOTTOM: .004[0.10], SIDE/SIDE: .003[0.08].
 5. PARTS TO BE PACKAGED IN TAPE & REEL. FOR QTY'S LESS THAN 125 PCS, NO TRAILER OR LEADER WILL BE SUPPLIED.
 6. NOTE DELETED.
 7. SMALL QUANTITIES WILL NOT BE WOUND ON A REEL.

THIS CONNECTOR IS NOT CAPABLE OF WITHSTANDING TYPICAL LEAD FREE PROCESSING TEMPERATURES.
ANY REV MADE TO THIS PRINT MUST HAVE AN UPDATED MKT PRINT

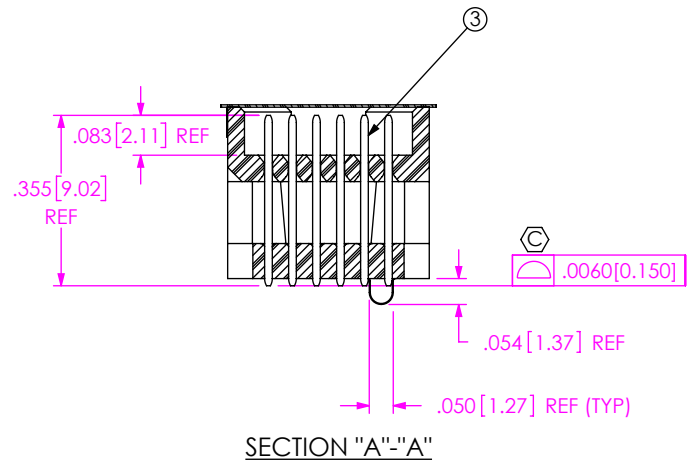
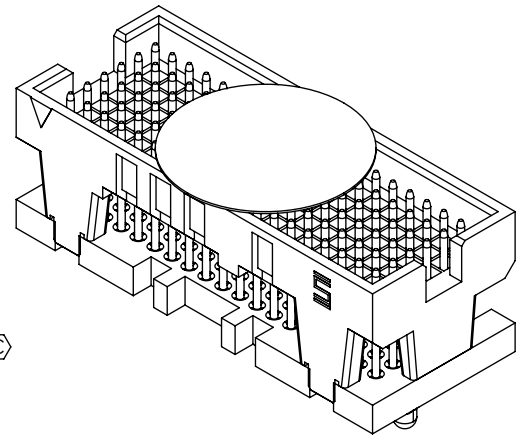
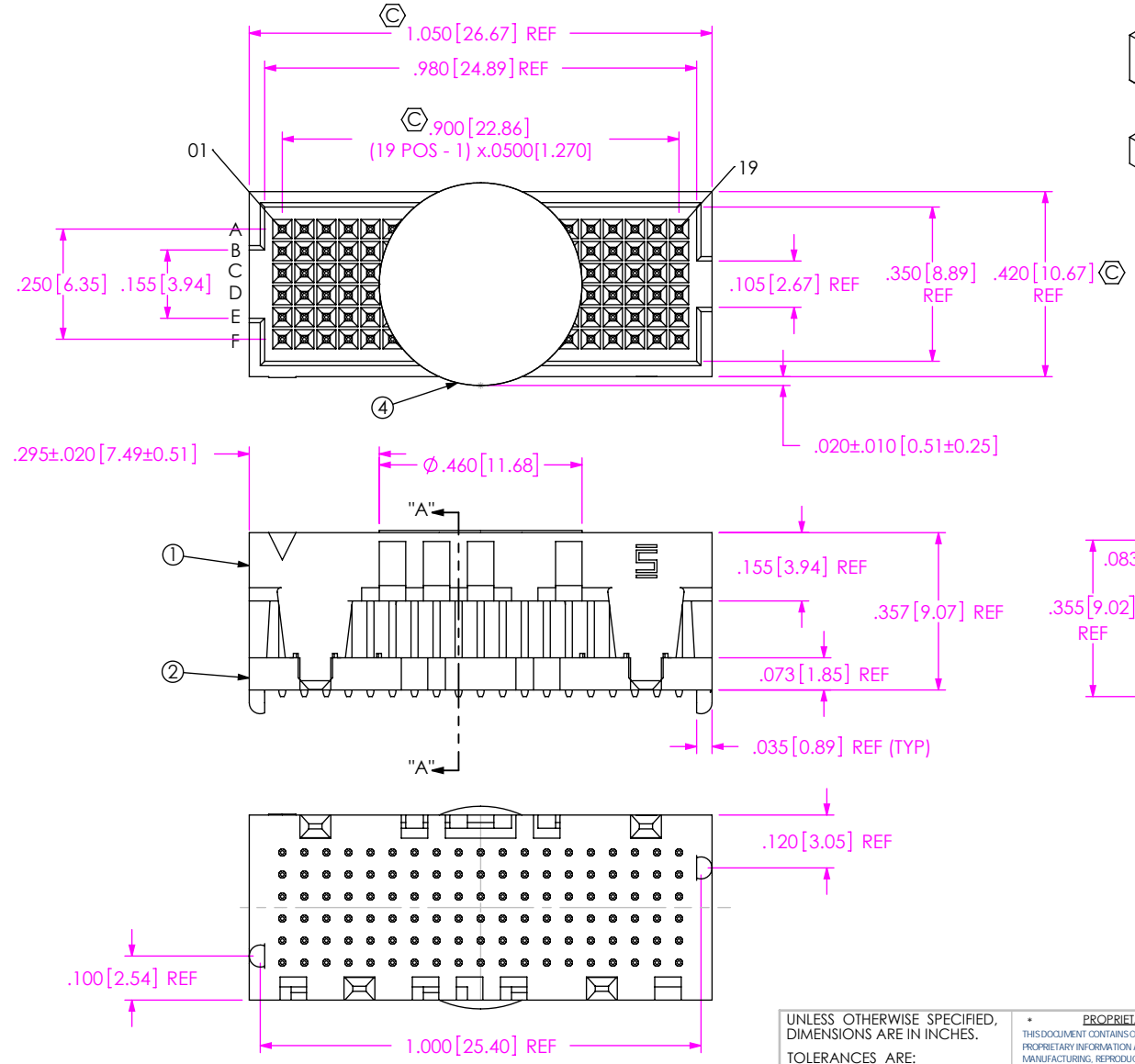

ITEM NO.	PART NUMBER	QUANTITY	MATERIAL
1	ASP-105991-01-B	1.0000	VECTRA E130i, COLOR: BLACK, UL RATING 94V-0
2	ASP-105991-02-B	1.0000	VECTRA E130i, COLOR: BLACK
3	ASP-105992-02-P-H	114.00	BRASS ALLOY 260, 3/4 HARD
4	K-850-650	1.0000	POLYIMIDE FILM
5	CT-ASP1232MS	1.0000	CONDUCTIVE POLYMER

UNLESS OTHERWISE SPECIFIED, DIMENSIONS ARE IN INCHES.

TOLERANCES ARE:
 DECIMALS .XX: ±.01[0.3]
 .XXX: ±.005[0.13]
 .XXXX: ±.0020[0.051]

ANGLES 2°

PROPRIETARY NOTE
 THIS DOCUMENT CONTAINS CONFIDENTIAL AND PROPRIETARY INFORMATION AND ALL DESIGN, MANUFACTURING, REPRODUCTION, USE, PATENT RIGHTS AND SALES RIGHTS ARE EXPRESSLY RESERVED BY SAMTEC, INC. THIS DOCUMENT SHALL NOT BE DISCLOSED, IN WHOLE OR PART, TO ANY UNAUTHORIZED PERSON OR ENTITY NOR REPRODUCED, TRANSFERRED OR INCORPORATED IN ANY OTHER PROJECT IN ANY MANNER WITHOUT THE EXPRESS WRITTEN CONSENT OF SAMTEC, INC.

DO NOT SCALE DRAWING SHEET SCALE: 2.5:1

PLATING:
 ENTIRE PIN: .000030 GOLD OVER .000050 NICKEL

DESCRIPTION:
 VITA 42 (NON SOLDERBALL) SOCKET ASSEMBLY

DWG. NO. ASP-105885-01

BY: T.WERNE 4/7/2003 SHEET 1 OF 3

520 PARK EAST BLVD, NEW ALBANY, IN 47150
 PHONE: 812-944-6733 FAX: 812-948-5047
 e-Mail info@SAMTEC.com code 55322

c:\enterprise\vaulf\DWG\MISC\MKTG\ASP-105885-01-MKT.SLDDRW



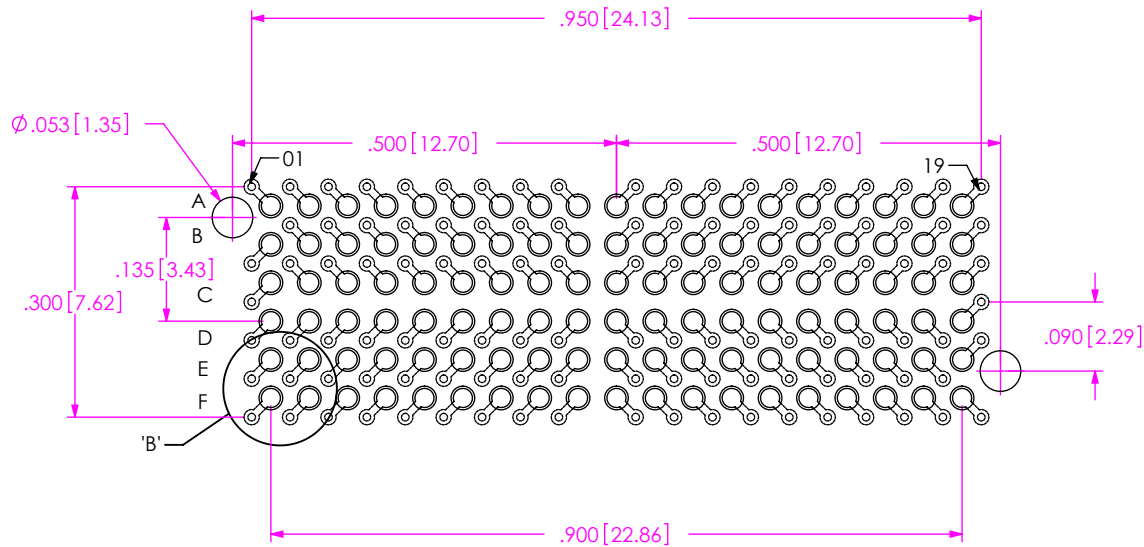

RECOMMENDED BOARD LAYOUT

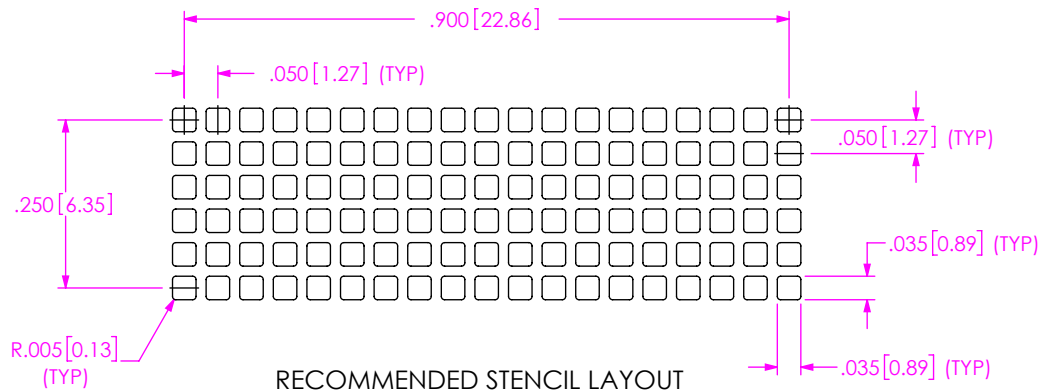

RECOMMENDED STENCIL LAYOUT

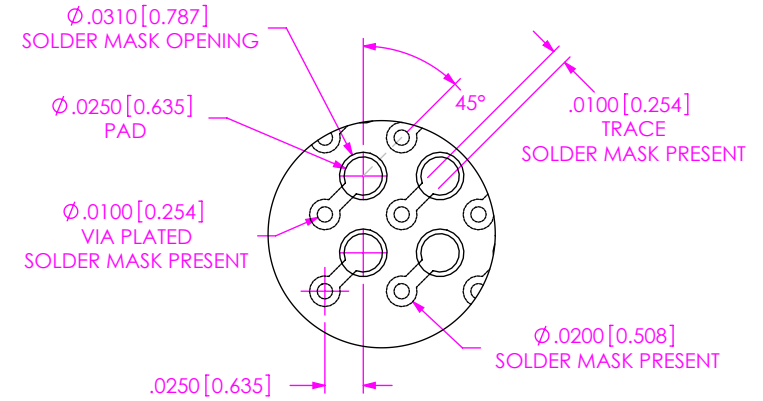

DETAIL 'B'
SCALE 8:1

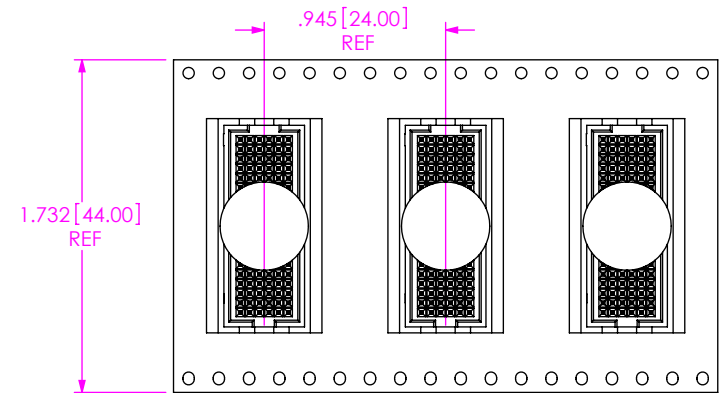

USER DIRECTION OF UN-REELING
POCKET NOT DETAILED

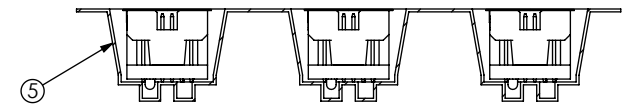

PACKAGING VIEW

PROPRIETARY NOTE
THIS DOCUMENT CONTAINS CONFIDENTIAL AND PROPRIETARY INFORMATION AND ALL DESIGN, MANUFACTURING, REPRODUCTION, USE, PATENT RIGHTS AND SALES RIGHTS ARE EXPRESSLY RESERVED BY SAMTEC, INC. THIS DOCUMENT SHALL NOT BE DISCLOSED, IN WHOLE OR PART, TO ANY UNAUTHORIZED PERSON OR ENTITY NOR REPRODUCED, TRANSFERRED OR INCORPORATED IN ANY OTHER PROJECT IN ANY MANNER WITHOUT THE EXPRESS WRITTEN CONSENT OF SAMTEC, INC.

samtec

520 PARK EAST BLVD, NEW ALBANY, IN 47150
PHONE: 812-944-6733 FAX: 812-948-5047
e-Mail info@SAMTEC.com code 55322

SHEET SCALE: 4:1

DESCRIPTION:
VITA 42 (NON SOLDERBALL) SOCKET ASSEMBLY

DWG. NO. ASP-105885-01

BY: T.WERNE 4/7/2003 SHEET 2 OF 3

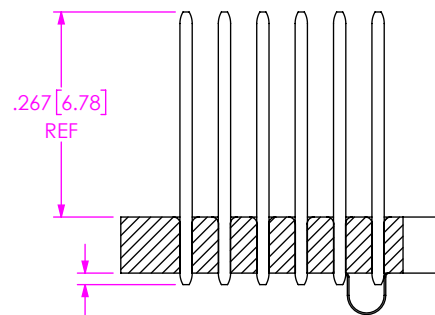

.015 ± .002 [0.38 ± 0.05]

IN-PROCESS 1

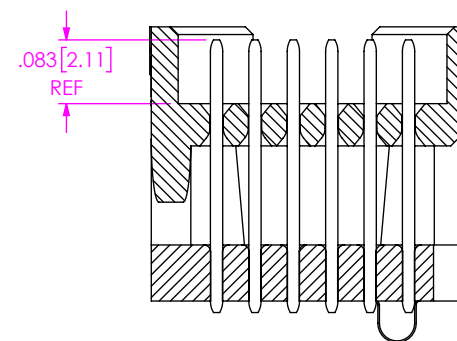

.083 [2.11]
REF

IN-PROCESS 2

PROPRIETARY NOTE

THIS DOCUMENT CONTAINS CONFIDENTIAL AND PROPRIETARY INFORMATION AND ALL DESIGN, MANUFACTURING, REPRODUCTION, USE, PATENT RIGHTS AND SALES RIGHTS ARE EXPRESSLY RESERVED BY SAMTEC, INC. THIS DOCUMENT SHALL NOT BE DISCLOSED, IN WHOLE OR PART, TO ANY UNAUTHORIZED PERSON OR ENTITY NOR REPRODUCED, TRANSFERRED OR INCORPORATED IN ANY OTHER PROJECT IN ANY MANNER WITHOUT THE EXPRESS WRITTEN CONSENT OF SAMTEC, INC.



520 PARK EAST BLVD, NEW ALBANY, IN 47150
PHONE: 812-944-6733 FAX: 812-948-5047
e-Mail info@SAMTEC.com code 55322

SHEET SCALE: 4:1

DESCRIPTION:
VITA 42 (NON SOLDERBALL) SOCKET ASSEMBLY

DWG. NO.
ASP-105885-01

BY: T.WERNE 4/7/2003 SHEET 3 OF 3