

DO NOT SCALE FROM THIS PRINT

- NOTES:
- ITEMS -1, -2, & -3 NOT AVAILABLE AS STANDARD, CUTOM FOR VARIATION OF VITA 42 XMC STANDARDS.
 - ⊕ REPRESENTS A CRITICAL DIMENSION.
 - MAXIMUM BURR ALLOWANCE: .0015[0.038]
 - MAXIMUM CUT FLASH: .010[0.25]
 - MINIMUM PUSHOUT FORCE: .5 LB [2.22N]
 - MAXIMUM ALLOWABLE BOW; TOP/BOTTOM: .006[0.15], SIDE/SIDE: .003[0.08], ⊕
 - PARTS TO BE PACKAGED IN TAPE & REEL. FOR QTY'S LESS THAN 125 PCS, NO TRAILER OR LEADER WILL BE SUPPLIED.
 - LEAD FREE SOLDER BALLS

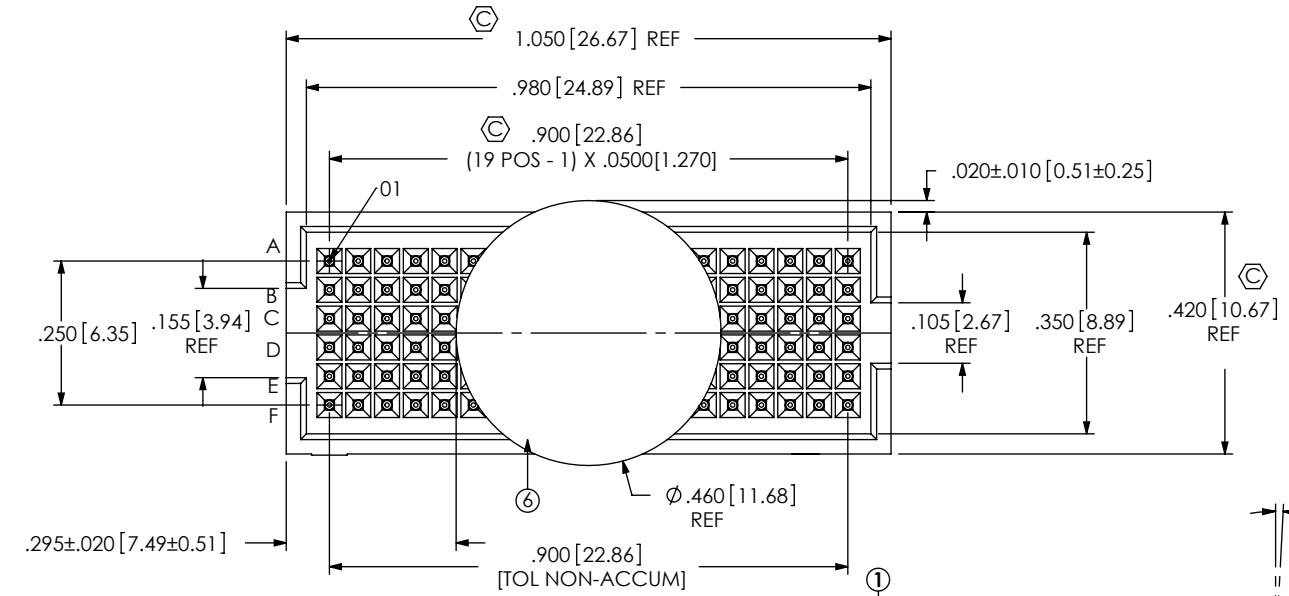

DETAIL 'G'
SCALE 10:1
SOLDER BALL REMOVED FOR CLARITY

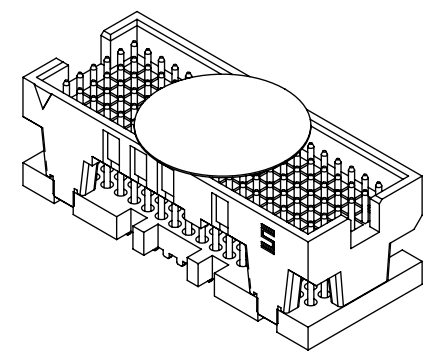
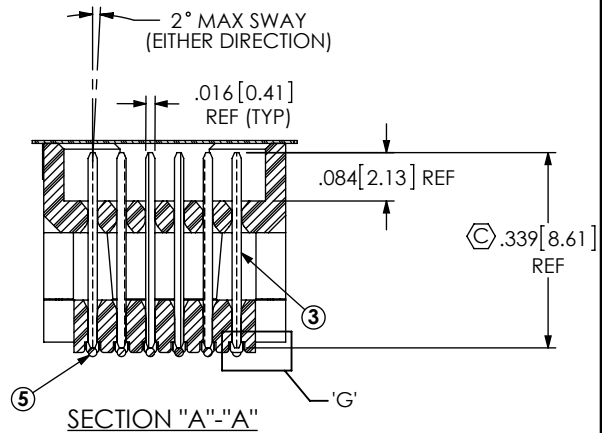
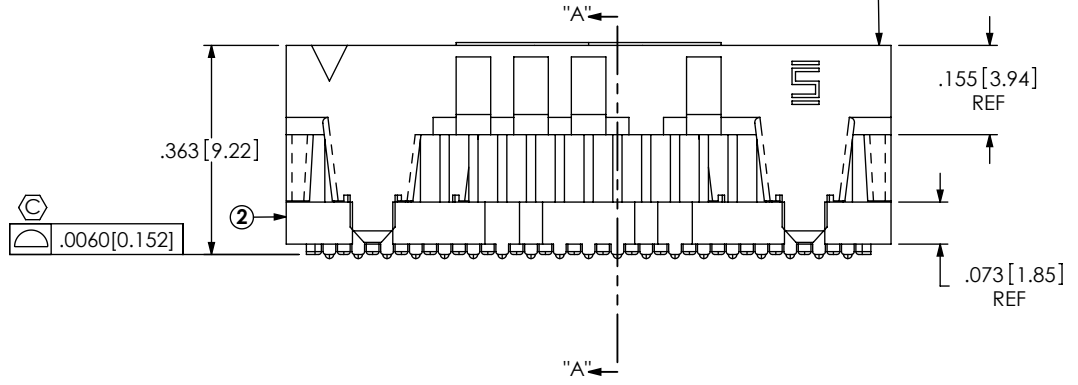

ITEM NO.	PART NUMBER	QUANTITY	MATERIAL
1	ASP-144052-01-B	1.0000	UL 94 V0, COLOR: BLACK
2	ASP-136535-01-B	1.0000	UL 94 V0, COLOR: BLACK
3	ASP-104554-02-P-H	114.00	BRASS ALLOY 260, 3/4 HARD
4	CT-ASP1134MS	.00571	CONDUCTIVE POLYMER
5	SDB-030-9653	114.00	96.5% TIN / 3% SILVER / 0.5% COPPER
6	K-850-650	1.0000	POLYIMIDE FILM

UNLESS OTHERWISE SPECIFIED, DIMENSIONS ARE IN INCHES. TOLERANCES ARE: DECIMALS ANGLES .XX: ±.01[0.3] 2° .XXX: ±.005[0.13] .XXXX: ±.0020[0.051]	* PROPRIETARY NOTE * THIS DOCUMENT CONTAINS CONFIDENTIAL AND PROPRIETARY INFORMATION AND ALL DESIGN, MANUFACTURING, REPRODUCTION, USE, PATENT RIGHTS AND SALES RIGHTS ARE EXPRESSLY RESERVED BY SAMTEC, INC. THIS DOCUMENT SHALL NOT BE DISCLOSED, IN WHOLE OR PART, TO ANY UNAUTHORIZED PERSON OR ENTITY NOR REPRODUCED, TRANSFERRED OR INCORPORATED IN ANY OTHER PROJECT IN ANY MANNER WITHOUT THE EXPRESS WRITTEN CONSENT OF SAMTEC, INC.	 520 PARK EAST BLVD, NEW ALBANY, IN 47150 PHONE: 812-944-6733 FAX: 812-948-5047 e-Mail: info@SAMTEC.com code 55322

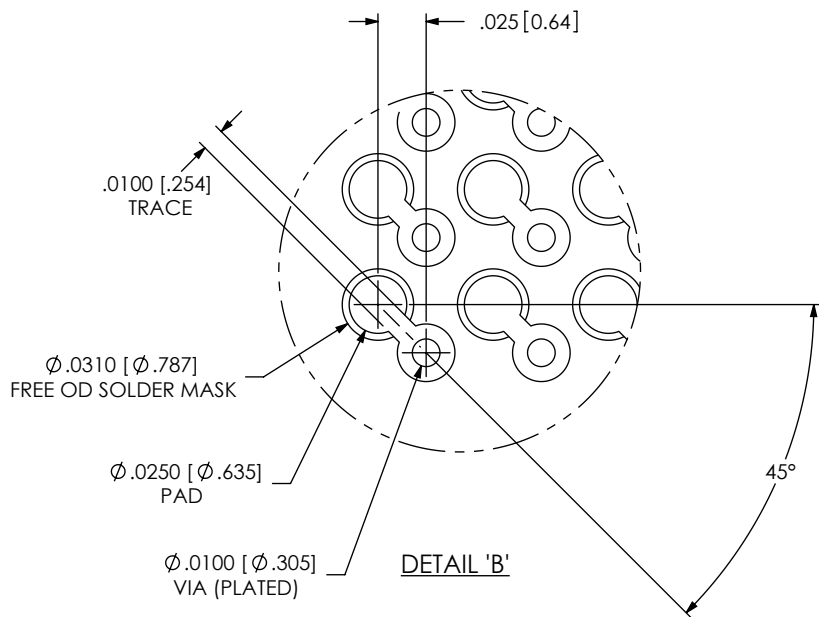
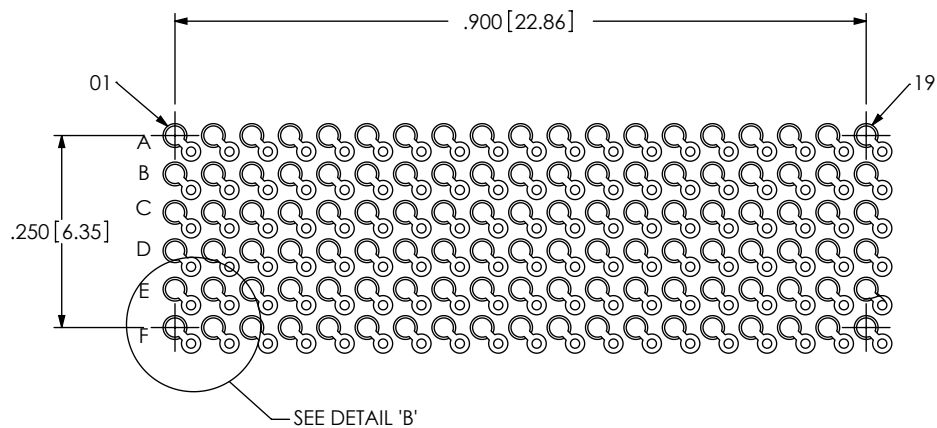

RECOMMENDED BOARD LAYOUT

RECOMMENDED STENCIL LAYOUT
STENCIL TO BE .0060[0.152] THICK

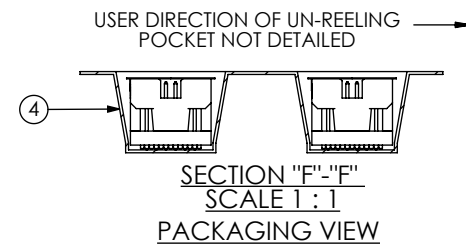
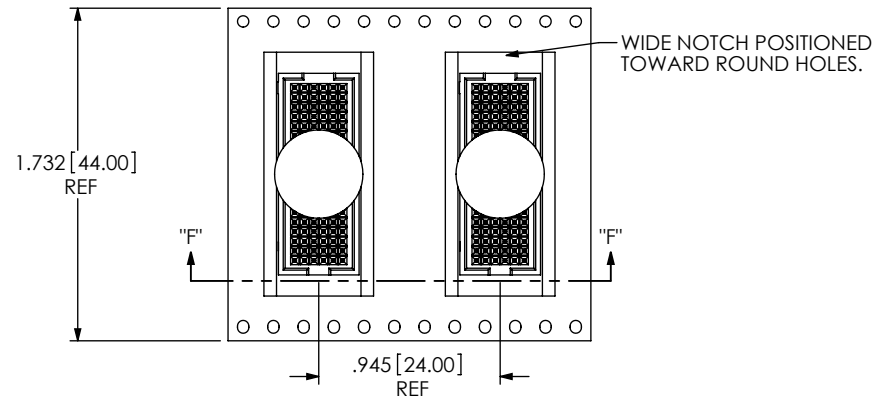
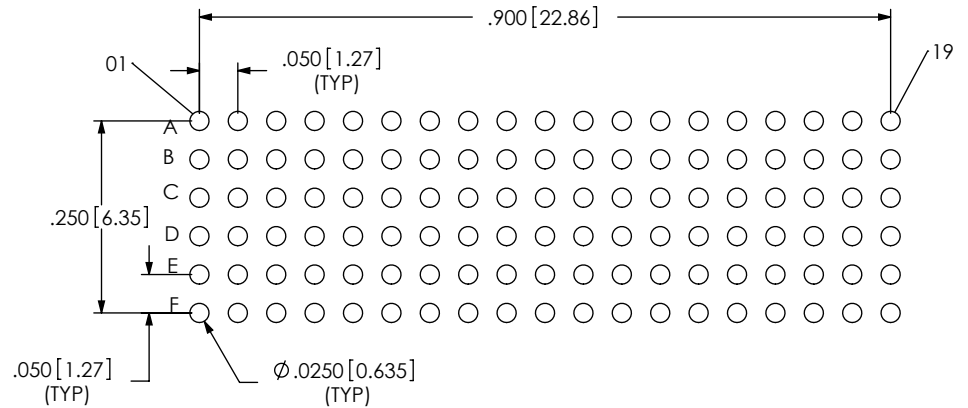

<p>PROPRIETARY NOTE</p> <p>THIS DOCUMENT CONTAINS CONFIDENTIAL AND PROPRIETARY INFORMATION AND ALL DESIGN, MANUFACTURING, REPRODUCTION, USE, PATENT RIGHTS AND SALES RIGHTS ARE EXPRESSLY RESERVED BY SAMTEC, INC. THIS DOCUMENT SHALL NOT BE DISCLOSED, IN WHOLE OR PART, TO ANY UNAUTHORIZED PERSON OR ENTITY NOR REPRODUCED, TRANSFERRED OR INCORPORATED IN ANY OTHER PROJECT IN ANY MANNER WITHOUT THE EXPRESS WRITTEN CONSENT OF SAMTEC, INC.</p>	<p>samtec</p> <p>520 PARK EAST BLVD. NEW ALBANY, IN 47150 PHONE: 812-944-6733 FAX: 812-948-5047 e-Mail info@SAMTEC.com code 55322</p>	
	<p>SHEET SCALE: 3:1</p>	<p>DESCRIPTION: VITA 42 (LEAD FREE) SOCKET ASSEMBLY</p>
<p>F:\DWG\MISC\MKTG\ASP-103614-04-MKT.SLDDRW</p>		<p>DWG. NO. ASP-103614-04</p>
<p>BY: TAMMY W 09/11/06</p>		<p>SHEET 2 OF 2</p>