

© COPYRIGHT 2012 BY INDUSTRIAL FIBER OPTICS, INC.
ALL RIGHTS RESERVED.

REVISIONS

REV	DESCRIPTION	ECO	DATE	DWN	APVD
A	Initial release		10/1/2012	BB	AR

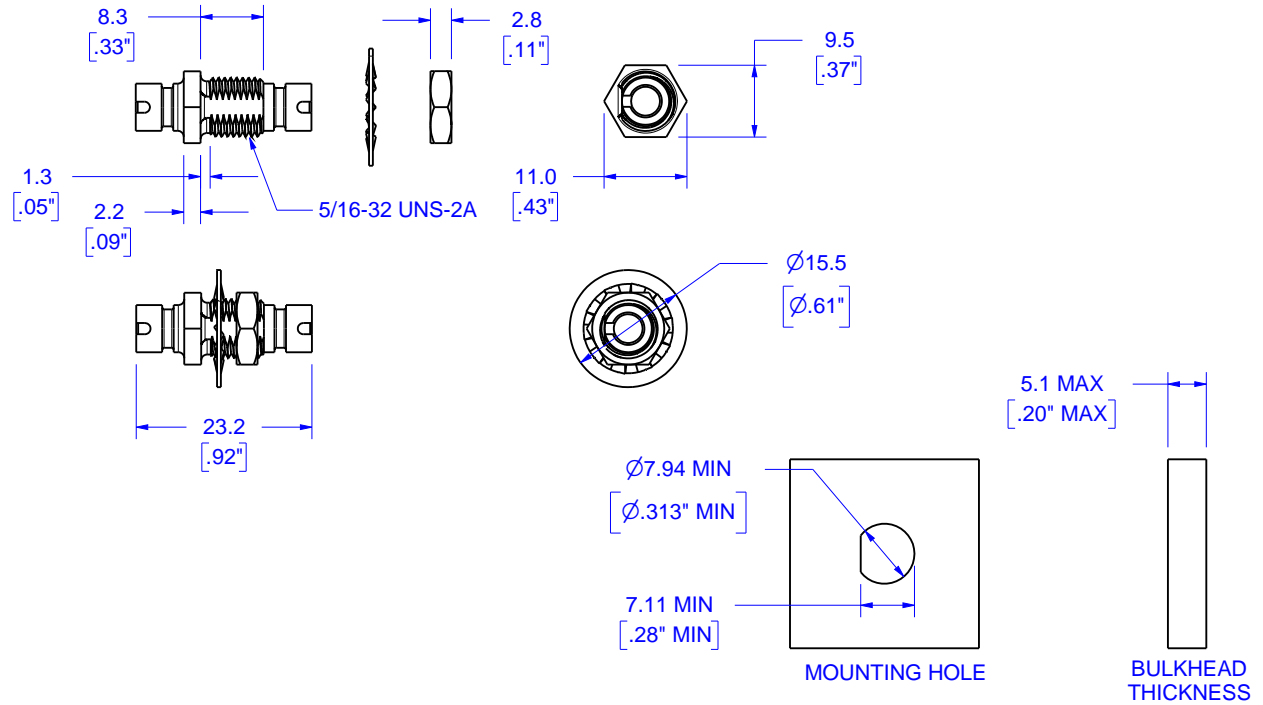
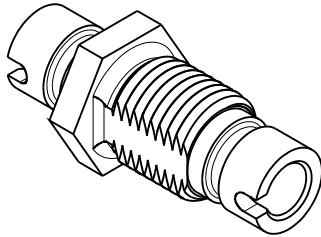

- NOTES:
1. RoHS compliant.
 2. -40° C to 85° C operating temperature.
 3. Electropolished stainless steel body and nut for maximum corrosion resistance.
 4. Suitable for use with simplex latching VersaLink connectors.

INCLUDES 3/8" HEX NUT AND LOCK WASHER

UNLESS OTHERWISE SPECIFIED DIMENSIONS MILLIMETERS [IN.]	PRODUCT	INDUSTRIAL FIBER OPTICS TEMPE, AZ 85281			
	MATERIAL				
DIMENSIONS ARE FOR REFERENCE ONLY NO TOLERANCES MAY BE IMPLIED FROM THIS DOCUMENT	FINISH	Electropolished	NAME		
	DRAWN BY	B. Bidwell	VersaLink Mating Sleeve		
	DATE	10/1/2012			
	CHECKED BY	A. Reyes	SIZE	SCALE	PART NUMBER
	DATE	10/2/2012	A	1:1	51 0137
		DO NOT SCALE DRAWING		REV	A
					Sheet 1 of 1

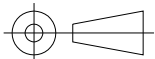

METRIC