

High-Voltage Types Application Guide, Mica Capacitors

Types 271, 272, 273 — Rectangular Case, High-Current and High-Voltage Circuits

Types 271, 272, 273 are designed for frequencies ranging from 100 kHz to 3 MHz and are well suited for high-current and high-voltage radio transmitter circuit applications. Cast in rectangular cases, these capacitors are electrically equivalent to MIL-C-5 Styles CM65 through CM73 in capacitance and current ratings, but are far superior in environmental capability, temperature range, physical size, mounting configuration and reliability.



Highlights

- ◆ Type 273 permits stand-off mounting
- ◆ Highly shock resistant
- ◆ Optional aluminum mounting plates
- ◆ Convenient mounting
- ◆ Cast in rectangular cases

Specifications

Capacitance Range:	47 pF to 0.1 μ F
Voltage Range:	1 to 8 kV _{pk}
Capacitance Tolerance:	$\pm 2\%$ (G), $\pm 5\%$ (J)
Temperature Range:	-55 °C to 125 °C

Type 271 Ratings

Cap (pF)	Catalog Part Number	Maximum AC Current at 65 °C			
		3 MHz (A)	1 MHz (A)	300 kHz (A)	100 kHz (A)
250 Peak Volts					
47000	27102B473J00	11	11	9.1	4.7
50000	27102B503J00	11	11	9.1	4.7
51000	27102B513J00	11	11	9.1	4.7
56000	27102B563J00	11	11	9.1	4.7
62000	27102B623J00	11	11	9.1	5.1
68000	27102B683J00	11	11	9.1	5.1
75000	27102B753J00	11	11	9.1	5.1
82000	27102B823J00	11	11	9.1	5.1
91000	27102B913J00	11	11	9.1	5.6
100000	27102B104J00	11	11	9.1	5.6
500 Peak Volts					
27000	27105B273J00	11	11	7.5	3.9
30000	27105B303J00	11	11	8.2	3.9
33000	27105B333J00	11	11	8.2	4.3
36000	27105B363J00	11	11	8.2	4.3
39000	27105B393J00	11	11	8.2	4.3
43000	27105B433J00	11	11	9.1	4.7
1,000 Peak Volts					
10000	27110B103J00	10	9.1	5.1	2.4
11000	27110B113J00	11	10	5.6	2.7
12000	27110B123J00	11	10	6.2	3.0
13000	27110B133J00	11	11	6.8	3.0
15000	27110B153J00	11	11	6.8	3.3
16000	27110B163J00	11	11	6.8	3.3
18000	27110B183J00	11	11	7.5	3.3
20000	27110B203J00	11	11	7.5	3.6
22000	27110B223J00	11	11	7.5	3.6
24000	27110B243J00	11	11	7.5	3.6
1,500 Peak Volts					
8000	27115B802J00	10	8.2	4.7	2.2
8200	27115B822J00	10	8.2	4.7	2.2
9100	27115B912J00	10	8.2	4.7	2.4
2700	27120B272J00	6.8	5.1	2.7	1.3
2,000 Peak Volts					
3000	27120B302J00	7.5	5.1	3.0	1.3
3300	27120B332J00	7.5	5.6	3.0	1.5
3600	27120B362J00	7.5	5.6	3.3	1.5
3900	27120B392J00	8.2	6.2	3.3	1.6

Cap (pF)	Catalog Part Number	Maximum AC Current at 65 °C			
		3 MHz (A)	1 MHz (A)	300 kHz (A)	100 kHz (A)
4000	27120B402J00	8.2	6.2	3.3	1.6
4300	27120B432J00	8.2	6.2	3.6	1.6
4700	27120B472J00	8.2	6.8	3.6	1.8
5000	27120B502J00	8.2	6.8	3.6	1.8
5100	27120B512J00	8.2	6.8	3.6	1.8
5600	27120B562J00	9.1	7.5	3.9	2.0
6000	27120B602J00	9.1	7.5	4.3	2.0
6200	27120B622J00	9.1	7.5	4.3	2.0
6800	27120B682J00	10.0	7.5	4.3	2.0
7500	27120B752J00	10.0	8.2	4.7	2.2
3,000 Peak Volts					
47	27130B470J00	1.2	0.51	0.15	0.051
51	27130B510J00	1.3	0.51	0.18	0.056
56	27130B560J00	1.3	0.56	0.20	0.056
62	27130B620J00	1.5	0.62	0.22	0.068
68	27130B680J00	1.5	0.62	0.24	0.075
75	27130B750J00	1.5	0.62	0.27	0.082
82	27130B820J00	1.6	0.68	0.27	0.082
91	27130B910J00	1.6	0.68	0.33	0.091
100	27130B101J00	1.8	0.75	0.33	0.10
110	27130B111J00	1.8	0.82	0.36	0.12
120	27130B121J00	2	0.91	0.39	0.15
130	27130B131J00	2	0.91	0.43	0.16
150	27130B151J00	2.2	1.0	0.47	0.18
160	27130B161J00	2.2	1.1	0.51	0.20
180	27130B181J00	2.4	1.1	0.56	0.22
200	27130B201J00	2.4	1.2	0.62	0.24
220	27130B221J00	2.7	1.3	0.62	0.27
240	27130B241J00	2.7	1.3	0.68	0.30
250	27130B251J00	2.7	1.3	0.68	0.30
270	27130B271J00	3.1	1.5	0.75	0.30
300	27130B301J00	3.0	1.5	0.75	0.36
330	27130B331J00	3.0	1.6	0.82	0.36
360	27130B361J00	3.3	1.6	0.91	0.39
390	27130B391J00	3.3	1.8	0.91	0.43
430	27130B431J00	3.6	1.8	1.0	0.47
470	27130B471J00	3.6	2.0	1.1	0.47
500	27130B501J00	3.6	2.0	1.1	0.51
510	27130B511J00	3.6	2.0	1.1	0.51

High-Voltage Types Application Guide, Mica Capacitors

Types 271, 272 and 273 Ratings

Cap (pF)	Catalog Part Number	Maximum AC Current at 65 °C			
		3 MHz (A)	1 MHz (A)	300 kHz (A)	100 kHz (A)
560	27130B561J00	3.9	2.2	1.2	0.51
620	27130B621J00	3.9	2.4	1.2	0.56
680	27130B681J00	4.3	2.4	1.3	0.62
750	27130B751J00	4.3	2.7	1.3	0.62
820	27130B821J00	4.3	2.7	1.5	0.68
910	27130B911J00	4.7	3.0	1.5	0.68
1000	27130B102J00	4.7	3.0	1.6	0.75
1100	27130B112J00	5.1	3.3	1.6	0.82
1200	27130B122J00	5.1	3.3	1.8	0.82
1300	27130B132J00	5.6	3.6	1.8	0.91
1500	27130B152J00	5.6	3.9	2.0	0.91
1600	27130B162J00	5.6	3.9	2.0	1.0
1800	27130B182J00	6.2	4.3	2.2	1.1
2000	27130B202J00	6.2	4.3	2.4	1.1
2200	27130B222J00	6.8	4.7	2.4	1.2
250 Peak Volts					
250000	27202B254J00	15	18	15	8.2
500 Peak Volts					
82000	27205B823J00	15	18	15	8.2
91000	27205B913J00	15	18	15	8.2
100000	27205B104J00	15	18	15	8.2
200000	27205B204J00	15	18	15	8.2
1,000 Peak Volts					
56000	27210B563J00	15	16	15	8.2
62000	27210B623J00	15	18	15	8.2
68000	27210B683J00	15	18	15	8.2
75000	27215B333J00	15	18	15	8.2
1,500 Peak Volts					
24000	27215B243J00	13	15	12	6.8
27000	27215B273J00	13	15	12	6.8
30000	27215B303J00	13	15	12	6.8
33000	27215B333J00	13	15	13	7.5
36000	27215B363J00	13	16	13	7.5
39000	27215B393J00	15	16	13	7.5
43000	27215B433J00	15	16	13	7.5
47000	27215B473J00	15	16	13	7.5
50000	27215B503J00	15	16	15	7.5
51000	27215B513J00	15	16	15	7.5
2,000 Peak Volts					
8200	27220B822J00	10	10	7.5	3.9
9100	27220B912J00	11	10	8.2	4.3
10000	27220B103J00	11	11	8.2	4.3
11000	27220B113J00	11	11	8.2	4.7
12000	27220B123J00	11	11	9.1	4.7
13000	27220B133J00	12	12	9.1	5.1
15000	27220B153J00	12	12	10	5.1
16000	27220B163J00	12	12	10	5.6
18000	27220B183J00	12	13	10	5.6
20000	27220B203J00	13	13	11	6.2
22000	27220B223J00	13	13	11	6.2
3,000 Peak Volts					
2700	27230B272J00	8.2	6.8	4.3	2.2
3000	27230B302J00	8.2	6.8	4.7	2.2
3300	27230B332J00	8.2	6.8	4.7	2.4
3600	27230B362J00	8.2	7.5	5.1	2.4
3900	27230B392J00	9.1	7.5	5.6	2.7
4300	27230B432J00	9.1	7.5	5.6	2.7
4700	27230B472J00	9.1	8.2	6.2	3.0
5000	27230B502J00	9.1	8.2	6.2	3.0
5100	27230B512J00	9.1	8.2	6.2	3.0
5600	27230B562J00	9.1	9.1	6.2	3.3
6000	27230B602J00	10	9.1	6.8	3.6
6200	27230B622J00	10	9.1	6.8	3.6
6800	27230B682J00	10	9.1	6.8	3.6
7500	27230B752J00	10	9.1	6.8	3.9
5,000 Peak Volts					
47	27250B470J00	1.5	0.62	0.20	0.062
51	27250B510J00	1.6	0.68	0.22	0.062
56	27250B560J00	1.8	0.75	0.27	0.068
62	27250B620J00	1.8	0.82	0.30	0.075
68	27250B680J00	2	0.91	0.33	0.075
75	27250B750J00	2	1.0	0.36	0.082

Cap (pF)	Catalog Part Number	Maximum AC Current at 65 °C			
		3 MHz (A)	1 MHz (A)	300 kHz (A)	100 kHz (A)
82	27250B820J00	2.2	1.1	0.39	0.091
91	27250B910J00	2.4	1.2	0.4	0.091
100	27250B101J00	2.4	1.2	0.43	0.10
110	27250B111J00	2.7	1.3	0.51	0.15
120	27250B121J00	2.7	1.5	0.56	0.18
130	27250B131J00	3.0	1.6	0.62	0.22
150	27250B151J00	3.3	1.8	0.68	0.24
160	27250B161J00	3.3	1.8	0.75	0.27
180	27250B181J00	3.3	2.0	0.82	0.30
200	27250B201J00	3.6	2.0	0.82	0.33
220	27250B221J00	3.6	2.2	0.91	0.39
240	27250B241J00	3.6	2.4	1.0	0.43
250	27250B251J00	3.6	2.4	1.0	0.43
270	27250B271J00	3.9	2.4	1.1	0.47
300	27250B301J00	3.9	2.7	1.1	0.51
330	27250B331J00	4.3	2.7	1.2	0.51
360	27250B361J00	4.3	2.7	1.3	0.56
390	27250B391J00	4.3	2.7	1.3	0.62
430	27250B431J00	4.7	3.0	1.5	0.68
470	27250B471J00	4.7	3.3	1.5	0.68
500	27250B501J00	4.7	3.3	1.6	0.75
510	27250B511J00	4.7	3.3	1.6	0.75
560	27250B561J00	5.1	3.6	1.8	0.82
600	27250B601J00	5.1	3.6	1.8	0.82
620	27250B621J00	5.1	3.6	1.8	0.82
680	27250B681J00	2.1	3.6	1.8	0.82
750	27250B751J00	5.6	3.9	2.2	0.91
820	27250B821J00	5.6	3.9	2.4	1.0
910	27250B911J00	5.6	4.3	2.4	1.1
1000	27250B102J00	6.2	4.3	2.4	1.2
1100	27250B112J00	6.2	4.7	2.7	1.2
1200	27250B122J00	6.2	4.7	2.7	1.3
1300	27250B132J00	6.8	5.1	3.0	1.3
1500	27250B152J00	6.8	5.1	3.3	1.5
1600	27250B162J00	6.8	5.6	3.6	1.5
1800	27250B182J00	7.5	5.6	3.6	1.6
2000	27250B202J00	7.5	6.2	3.6	1.8
2200	27250B222J00	7.5	6.2	3.9	2.0
2400	27250B242J00	8.2	6.2	4.3	2.0
400 Peak Volts					
1000000	27304B204L00	18	25	22	12
600 Peak Volts					
200000	27306B204J00	18	25	22	12
250000	27306B254J00	18	25	22	12
300000	27306B304J00	18	25	22	12
400000	27306B404J00	18	25	22	12
500000	27306B504J00	18	25	22	12
600000	27306B604J00	18	25	22	12
750000	27306B754J00	18	25	22	12
2,000 Peak Volts					
100000	27320B104J00	18	23	18	10.5
4,000 Peak Volts					
25000	27340B253J00	18	24	19	11.5
30000	27340B303J00	18	24	19	11.5
40000	27340B403J00	18	24	20	12.0
50000	27340B503J00	18	25	21	12.0
5,000 Peak Volts					
20000	27350B203J00	18	23	18	10.5
8,000 Peak Volts					
200	27380B201J00	7.5	5.0	1.5	0.5
250	27380B251J00	7.5	5.0	1.5	0.5
500	27380B501J00	8.5	6.0	3.0	1.0
1000	27380B102J00	10.0	8.5	4.5	1.5
2000	27380B202J00	11.5	11.5	7.5	3.0
3000	27380B302J00	12.5	13.5	9.5	4.0
4000	27380B402J00	13.5	15.5	10.5	5.0
4500	27380B452J00	14.0	16.0	11.5	6.0
5000	27380B502J00	14.0	16.0	11.5	6.0
6000	27380B602J00	15.0	17.0	12.5	6.5
8000	27380B802J00	16.0	19.0	14.0	7.5
10000	27380B103J00	17.0	20.0	15.0	8.5

High-Voltage Types Ordering Information, Mica Capacitors

Ordering Information

Ordering Information: Order by complete part number, as below. For other options, write your requirements on your quote request or purchase order.

Cast-Case Part Numbering System

271 CDE Type	30 Rated Peak Voltage 10 = 1000 30 = 3000 250 = 25000	B Characteristic	470 Capacitance 470 = 47 pF 361 = 360 pF 122 = 1200 pF	J Capacitance Tolerance G = ±2% J = ±5%	O Temperature Range O = -55 °C to +125 °C	0 Mounting Style 0 = No mounting plate 1 = Mounting plate on bottom only 2 = Mounting plates on top and bottom
-------------------------	---	--------------------------	---	--	--	---

	Temp. Coeff. ppm/°C	Capacitance Drift	Standard Cap. Range
B	Not specified	Not specified	
C	-200 to +200	±(0.5% +0.1pF)	1-18 pF
D	-100 to +100	±(0.3% +0.1pF)	
E	-20 to +100	±(0.1% +0.1pF)	20-82 pF

Potted Case Styles

Transmitting mica capacitor type 272 is available in potted case package Type F2. To order this potted style use the part numbering below and contact us.

F2 CDE Type	30 Rated Peak Voltage (in hundreds of peak work- ing volts)	B Characteristic	470 Capacitance 470 = 47 pF 361 = 360 pF 122 = 1200 pF	J Capacitance Tolerance G = ±2% J = ±5% (standard)	M Temperature Range M = -55 °C to +70 °C
------------------------	---	--------------------------	---	--	---

Military Style Numbers

For the commercial equivalent to military style numbers CM66 through CM93 see the tables below.

Military Style No.	Equivalent CDE Type
CM66	271, Mounting Style 0
CM67	271, Mounting Style 1
CM68	271, Mounting Style 2
CM70	F2
CM71	272, Mounting Style 0
CM72	272, Mounting Style 1
CM73	272, Mounting Style 2
CM76	291, Mounting Style 0
CM77	291, Mounting Style 1
CM78	291, Mounting Style 2

Military Style No.	Equivalent CDE Type
CM81	292, Mounting Style 0
CM82	292, Mounting Style 1
CM83	292, Mounting Style 2
CM86	293, Mounting Style 0
CM87	293, Mounting Style 1
CM88	293, Mounting Style 2
CM91	294, Mounting Style 0
CM92	294, Mounting Style 1
CM93	294, Mounting Style 2

High-Voltage Types Application Guide, Mica Capacitors

Type 271

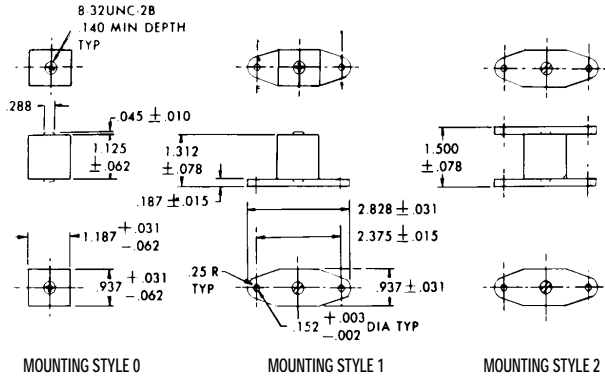

Type 273

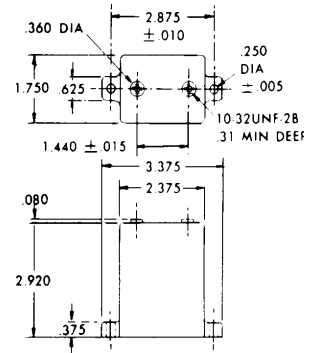

TOLERANCES UNLESS OTHERWISE SPECIFIED: ±0.031

Type 272

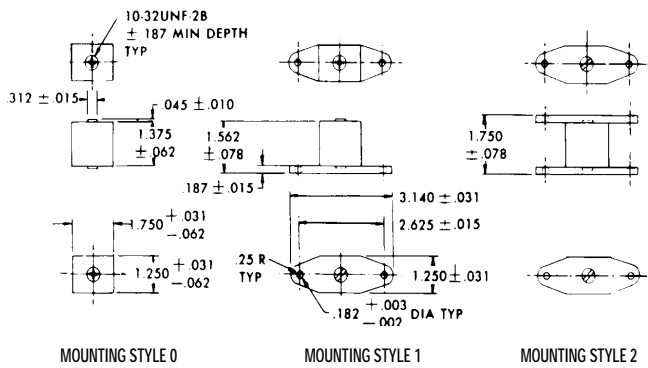

Cast-Case Styles

Type 291

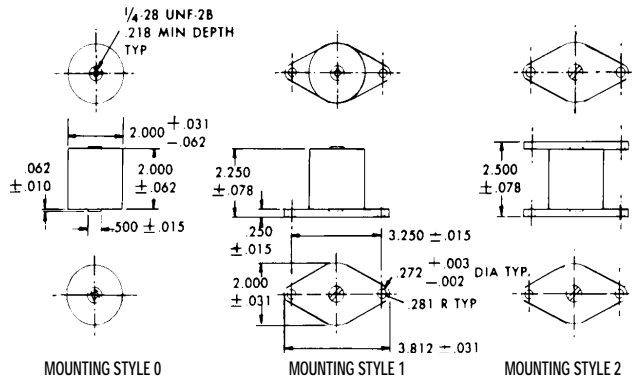

Type 292

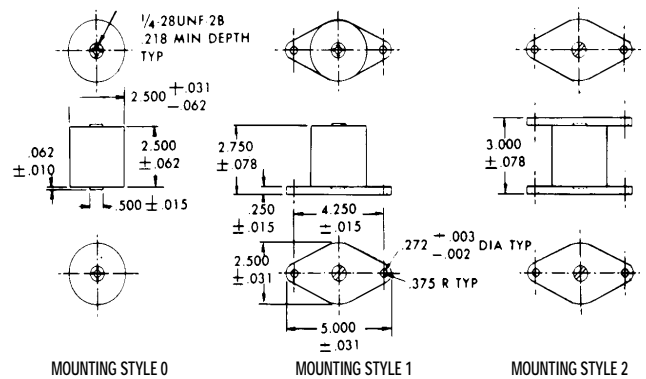

Type 293

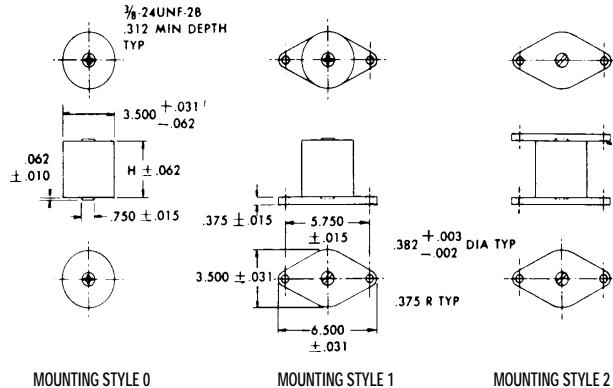

Type 294

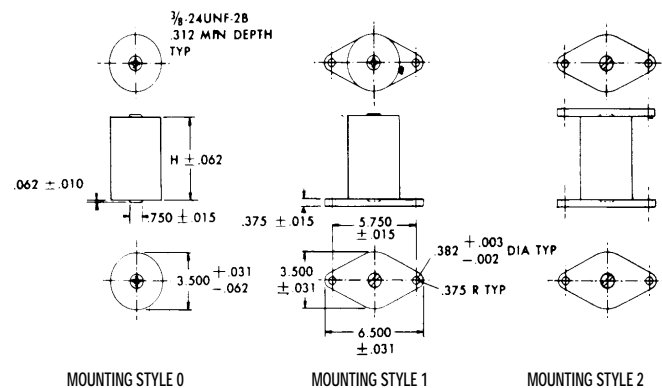

High-Voltage Types Application Guide, Mica Capacitors

Type 271 (CM 66)
Rated Current Versus Frequency

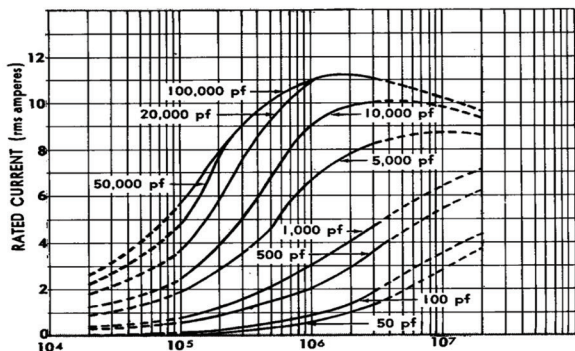

Type 272 (CM 71)
Rated Current Versus Frequency

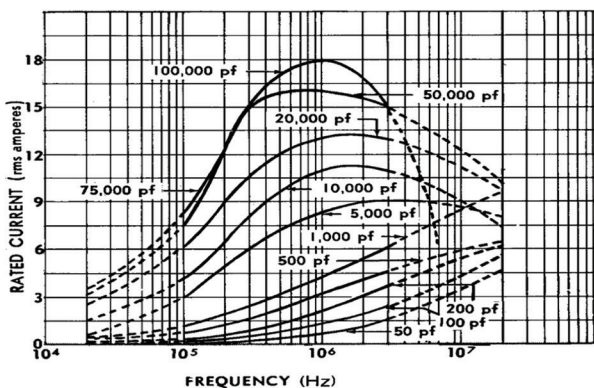

Type 273
Rated Current Versus Frequency

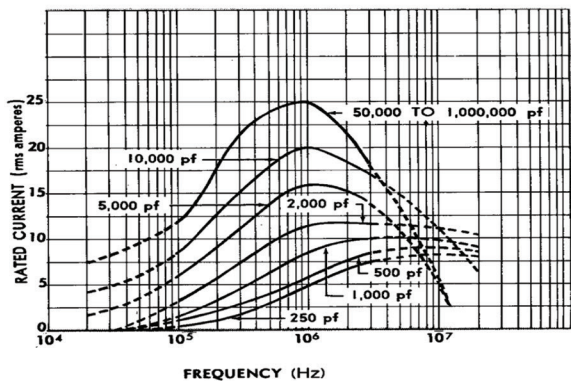

Type 291 (CM 76)
Rated Current Versus Frequency

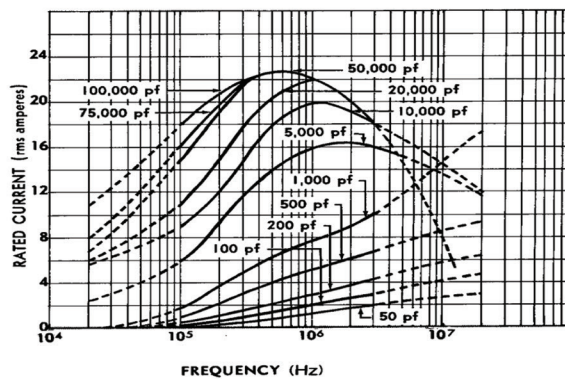

Type 292 (CM 81)
Rated Current Versus Frequency

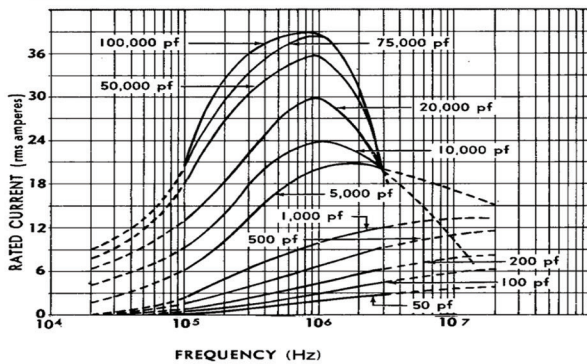

Type 293 (CM 86)
Rated Current Versus Frequency

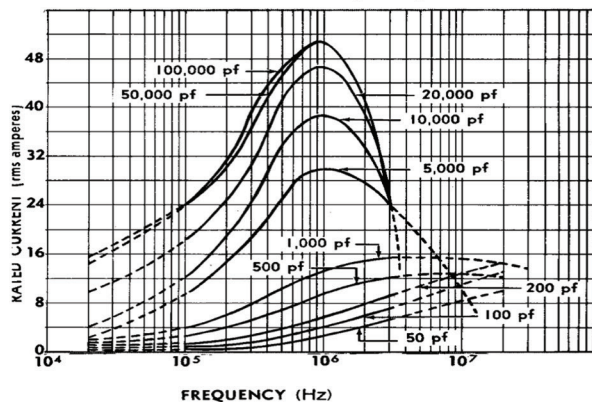

Type 294 (CM 91)
Rated Current Versus Frequency

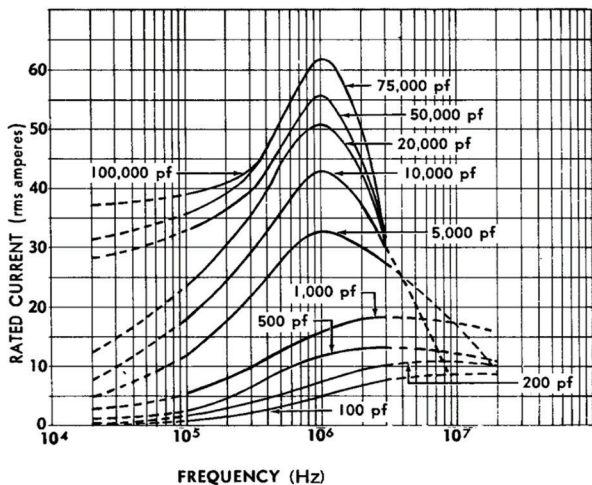

Type G5 (CM 95)
Rated Current Versus Frequency

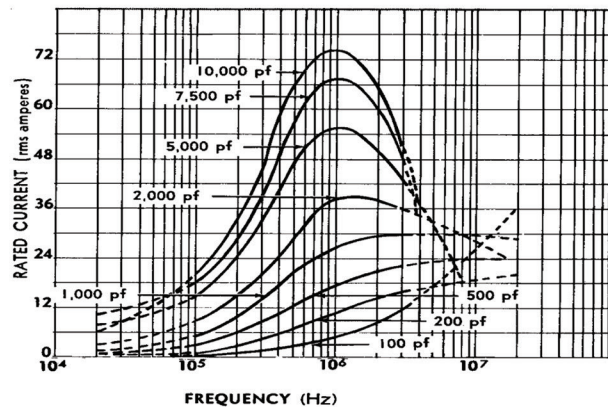

High-Voltage Types Application Guide, Mica Capacitors

Specifications

Capacitance is within tolerance when measured at these frequencies:

1–1000 pF @ 1 MHz

> 1000 pF @ 1 kHz

Dissipation Factor is typically less than 0.05% when measured as above. Dissipation factor (DF) equals $2\pi fRC$, where f is the test frequency, R is the equivalent series resistance (Ω), and C is nominal capacitance (F). Q is the reciprocal of the dissipation factor.

Operating Temperature Range is $-55\text{ }^{\circ}\text{C}$ to $+125\text{ }^{\circ}\text{C}$. Insulation Resistance is no less than $7500\text{ M}\Omega$ when measured at 100 Vdc.

Temperature Coefficient and Capacitance Drift: Measure the capacitors' capacitance at $25\text{ }^{\circ}\text{C}$, $55\text{ }^{\circ}\text{C}$, $25\text{ }^{\circ}\text{C}$, $125\text{ }^{\circ}\text{C}$, and at $25\text{ }^{\circ}\text{C}$ after stabilizing at each temperature. The capacitance will meet the limits of the Characteristic table shown in Ordering Information.

Rated Peak Voltage is not to be exceeded in actual use. Voltage ratings are in the listings and apply under the following conditions:

Temperature: Within the specified operating temperature range.

Altitude: Up to 50,000 feet or 3.4 inches of mercury.

Relative Humidity: Up to 80%.

Frequency: As specified.

Where pulse conditions are encountered, contact us.

Withstanding Voltage: Capacitors will withstand application of an ac potential between terminals having an rms value equal to the rated peak voltage at a frequency of 100 Hz or less without damage, arcing or breakdown. Apply the potential by raising the voltage from zero to the specified value. Apply the full potential for a minimum of 5 seconds.

Case Insulation: Capacitor cases will withstand, without damage, arcing or breakdown, a 60-Hz peak ac potential equal to twice the rated peak voltage applied between the terminals connected together and a metal electrode touching the case. Apply this potential for 1 to 5 seconds.

Current Ratings at various frequencies are in the listings and apply under the following conditions:

Temperature: $65\text{ }^{\circ}\text{C}$ maximum

Derating Factor: None

Vibration: Capacitors will withstand vibrational forces occurring at rates of from 10 to 55 Hz for $4\frac{1}{2}$ hours. The total excursion during vibration is 0.06 inches. At the end of this period, make the following inspections and tests:

Visual and Mechanical Inspection: No perceptible deterioration. Withstanding Voltage: As specified under Withstanding Voltage.

Insulation Resistance: No less than $7500\text{ M}\Omega$.

Capacitance Change: Not to exceed 3% of the nominal value or one picofarad, whichever is greater.

Temperature and Immersion Cycling: Capacitors will withstand the temperature and immersion cycles indicated in the tables below. Follow three temperature cycles by two immersion cycles. Make the measurements listed below no more than 30 minutes following the final immersion cycle:

Withstanding Voltage: As specified under Withstanding Voltage.

Insulation Resistance: No less than $7500\text{ M}\Omega$.

Capacitance: Change not to exceed 4% of the nominal value or one picofarad, whichever is greater.

Temperature Cycling Test Conditions

Steps	Temp ($^{\circ}\text{C}$)	Interval (Minutes)
1	$-55 + 0$ -3	30
2	$25 + 10$ -5	10 to 15
3	$125 + 3$ -0	30
4	$25 + 10$ -5	10 to 15

Immersion Test Conditions

•Number of cycles: 2

•Duration of each immersion: 15 minutes

•Immersion bath: Saturated solution of sodium chloride and water

•Temp. of hot bath: $65 - 0 + 5\text{ }^{\circ}\text{C}$

•Temp. of cold bath: $25 - 0 + 10\text{ }^{\circ}\text{C}$

Life Test: Subject all capacitors to a temperature of $55\text{ }^{\circ}\text{C}$ for 48 hours. Then subject units cast in rectangular cases (Types 271, 272, and 273) to a 60-Hz rms voltage equal to the rated peak voltage for 250 hours. Subject units cast in cylindrical cases (Types 291, 292, 293, and 294) to a 60-Hz rms voltage equal to 90% of the rated peak voltage for 250 hours. In both tests, maintain the temperature at $125\text{ }^{\circ}\text{C}$. After test, the capacitors will meet these requirements:

Withstanding Voltage: As specified under Withstanding Voltage.

Insulation Resistance: No less than $7500\text{ M}\Omega$.

Capacitance Change: Within the limits given in the table below or one picofarad, whichever is greater.

Characteristic Maximum Cap.

B	$\pm 8\%$
C	$\pm 3\%$
D	$\pm 3\%$
E	$\pm 3\%$

In addition, the capacitor must show no visual damage and the markings must be legible.

High-Voltage Types Application Guide, Mica Capacitors

Notice and Disclaimer: All product drawings, descriptions, specifications, statements, information and data (collectively, the "Information") in this datasheet or other publication are subject to change. The customer is responsible for checking, confirming and verifying the extent to which the Information contained in this datasheet or other publication is applicable to an order at the time the order is placed. All Information given herein is believed to be accurate and reliable, but it is presented without any guarantee, warranty, representation or responsibility of any kind, expressed or implied. Statements of suitability for certain applications are based on the knowledge that the Cornell Dubilier company providing such statements ("Cornell Dubilier") has of operating conditions that such Cornell Dubilier company regards as typical for such applications, but are not intended to constitute any guarantee, warranty or representation regarding any such matter – and Cornell Dubilier specifically and expressly disclaims any guarantee, warranty or representation concerning the suitability for a specific customer application, use, storage, transportation, or operating environment. The Information is intended for use only by customers who have the requisite experience and capability to determine the correct products for their application. Any technical advice inferred from this Information or otherwise provided by Cornell Dubilier with reference to the use of any Cornell Dubilier products is given gratis (unless otherwise specified by Cornell Dubilier), and Cornell Dubilier assumes no obligation or liability for the advice given or results obtained. Although Cornell Dubilier strives to apply the most stringent quality and safety standards regarding the design and manufacturing of its products, in light of the current state of the art, isolated component failures may still occur. Accordingly, customer applications which require a high degree of reliability or safety should employ suitable designs or other safeguards (such as installation of protective circuitry or redundancies or other appropriate protective measures) in order to ensure that the failure of an electrical component does not result in a risk of personal injury or property damage. Although all product-related warnings, cautions and notes must be observed, the customer should not assume that all safety measures are indicated in such warnings, cautions and notes, or that other safety measures may not be required.