

1

2

3

4

PRODUCT NUMBERING:
 10137238 - 0 0 X 0 LF
 LEAD FREE
 1: TYPE I
 2: TYPE II

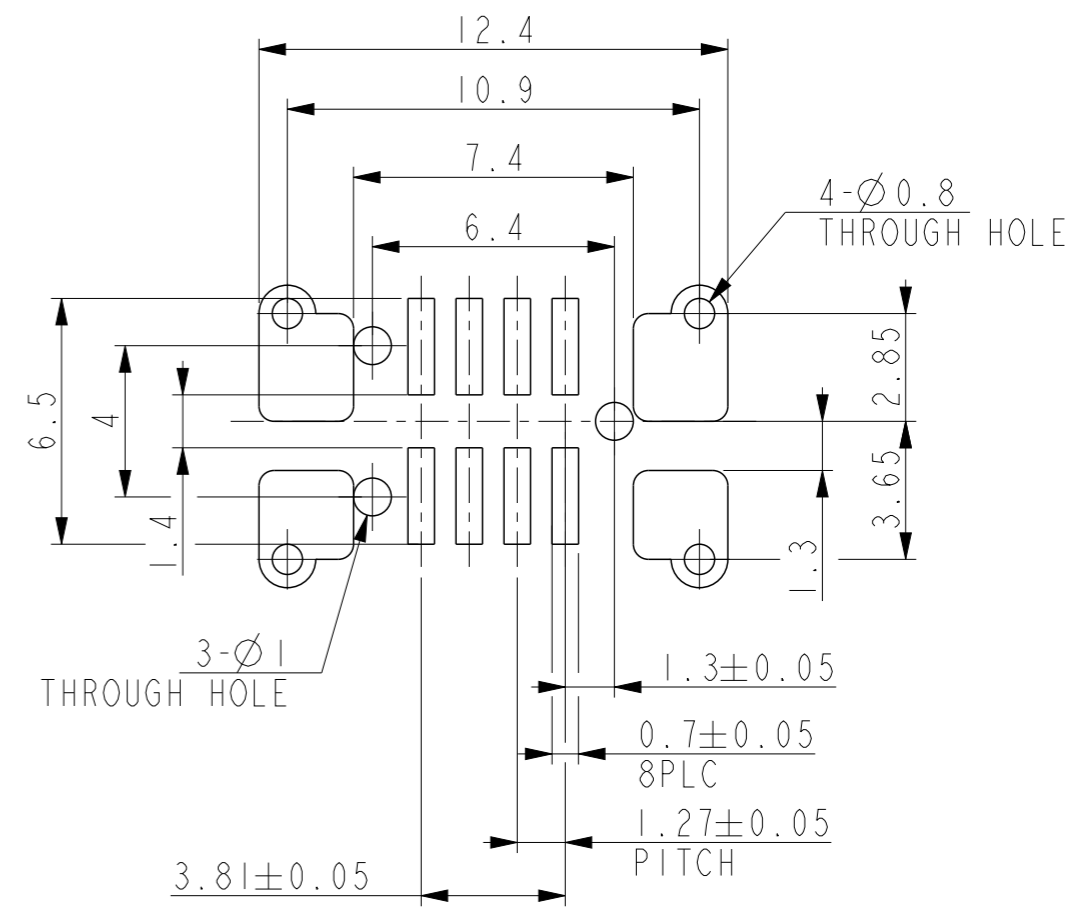

NOTES:

- MATERIAL AND FINISH
 CONTACT: COPPER ALLOY
 UNDER ALL SURFACE NICKEL 1.27µm MIN.
 TOP CONTACT AREA : GOLD 0.5µm MIN
 SOLDERING AREA : TIN PLATE.
 HOUSING: THERMO PLASTIC (UL94V-0)
 SHELL: COPPER ALLOY
 UNDER ALL SURFACE NICKEL
 TOP ALL SURFACE TIN
- COPLANARITY 0.1 MAX
- PACKAGING SPEC GS-14-2538

RECOMMENDED BOARD DIMENSION
 t=1.6
 GENERAL TOL. : ±0.1

Amphenol FCI

© 2016 AFCI

spec ref	GS-12-1346	dr	A P Sawanth	2016/09/07	projection	mm	size	A3	scale	5:1										
tolerance std	ISO 406 ISO 1101	eng	Mike Zhou	2017/11/13			ecn no	ELX-N-28452-1												
TOLERANCES UNLESS OTHERWISE SPECIFIED		chr	-	-			rel level	Released												
surface	linear	0.X	±0.3	Amphenol FCI	SMT VERTICAL MINI I/O CONN 1.27mm PITCH	cat. no.	Product - Customer Drw	sheet 1 of 2	ISO 1302	angular	0°	±5°	dwg no	10137238	rev	B				
		0.XX	±-																	
		0.XXX	±-																	

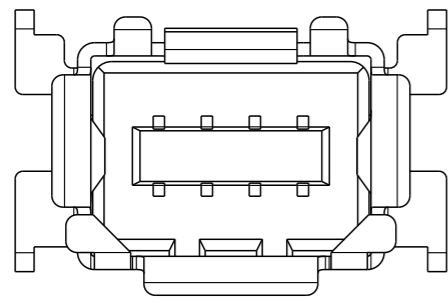

10137238-0020LF
TYPE II

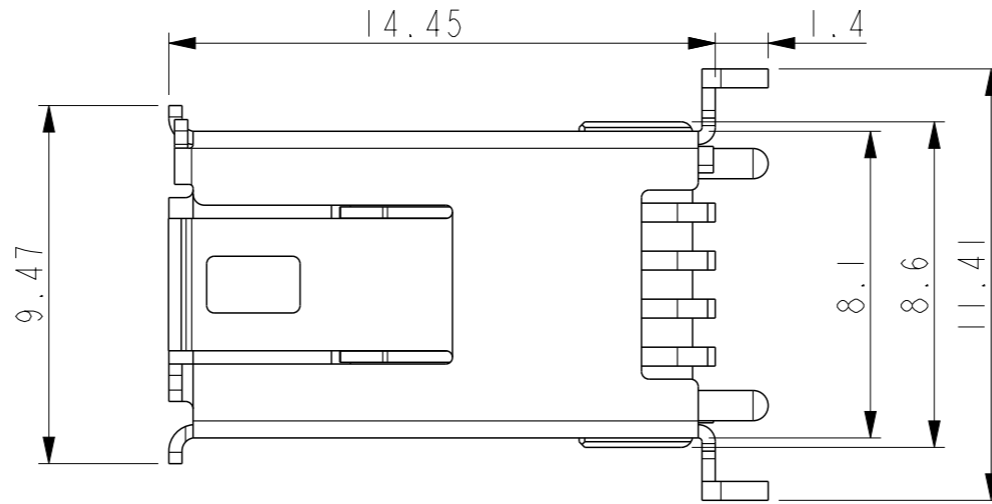

PART NUMBER	DESCRIPTION	POS
10137238-0010LF	TYPE I SMT RECEPTACLE	8
10137238-0020LF	TYPE II SMT RECEPTACLE	8

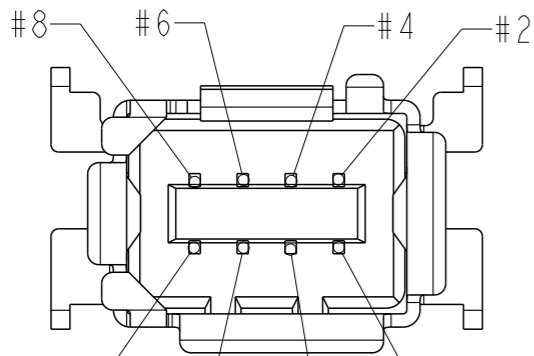

10137238-0010LF
TYPE I

CIRCUIT NO.

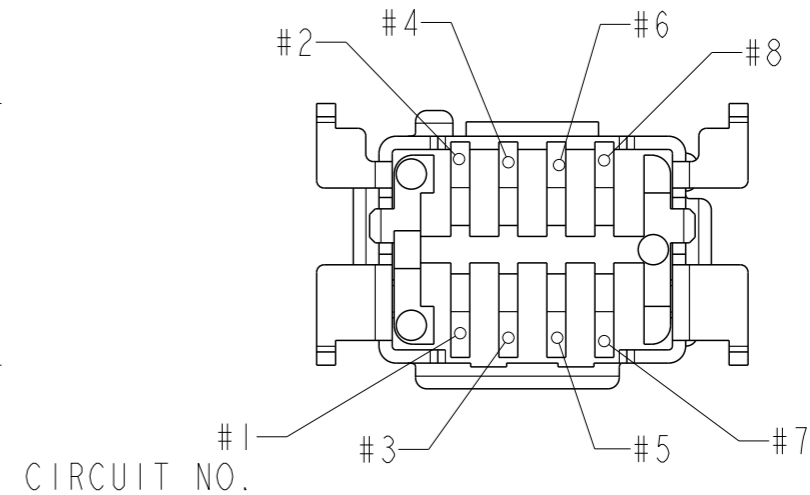
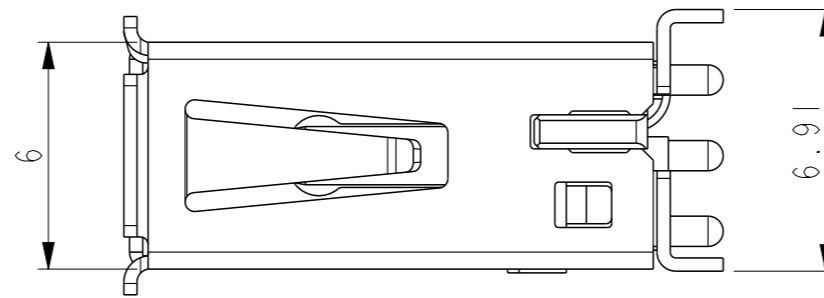

CIRCUIT NO.

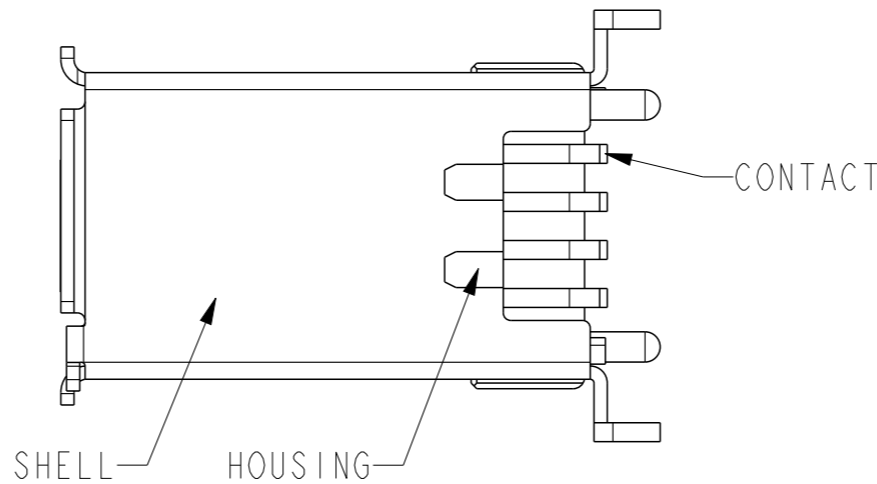

spec ref	GS-12-1346	dr	A P Sawanth	2016/09/07	projection	mm	size	A3	scale	5:1		
tolerance std	ISO 406 ISO 1101	eng	Mike Zhou	2017/11/13			ecn no	ELX-N-28452-1				
TOLERANCES UNLESS OTHERWISE SPECIFIED		chr	-	-			rel level	Released				
surface	linear	0.X	±0.3	Amphenol FCI	product family		SMT VERTICAL MINI I/O CONN		dwg no	10137238	rev	B
		0.XX	±-		1.27mm PITCH		cat. no.		Product - Customer Drw		sheet 2 of 2	
	angular	0°	±5°									

Amphenol FCI

© 2016 AFCI